

Appendix B1

Report: 2016 Annual Geotechnical Inspection

**Letter: Implementation Plan for 2016 Annual Geotechnical
Inspection Recommendations**



February 2017

REPORT ON

2016 Annual Geotechnical Inspection Meadowbank Gold Mine, Nunavut

Submitted to:

Agnico-Eagle Mines Limited
Meadowbank Division
PO Box 540
Baker Lake, Nunavut X0C 0A0

REPORT



Report Number: Doc 1549 1662181 Rev0

Distribution:

2 copies: Agnico-Eagle Mines Limited
1 copy: Golder Associates Ltd.





Executive Summary

Agnico-Eagle Mines Limited (AEM) mandated Golder Associés Ltée (Golder) to conduct the 2016 geotechnical inspection of the Meadowbank Gold Mine Project to comply with the requirements of AEM's Water Licence Permit. The inspection was conducted from September 8 to September 15, 2016, and covered the geotechnical aspects and the review of the available instrumentation data for the dewatering dikes, the tailings storage facility (TSF) structures, the structures along the All-Weather Private Road (AWPR) located between the mine site and the town of Baker Lake, the bulk fuel storage facility at the mine site and at Baker Lake, as well as other site facilities such as site roads, the landfill, the landfarm, the Stormwater Management Pond, the RSF till plug, the diffusers, the erosion and sediment protection structure and the airstrip.

At the time of the inspection, and based on the instrumentation data, the condition of the dewatering dikes appears stable. Due to technical problems with datalogger, some piezometers and thermistance data of East Dike are incomplete for the 2016 thawing period. It is recommended to fix the issue with these instruments to continue obtaining data. It is also recommended to flag the piezometers that recorded data below 0°C in the past at East Dike and Bay-Goose Dike and be very careful when interpreting their data, as they might be broken. Once a piezometer has frozen, it cannot be relied upon even if it thaws.

It is recommended that the ultramafic waste rock stockpile continue to be kept at a distance from the downstream toe of South Camp Dike to allow for good visual observation of the downstream toe area. No geotechnical concern were identified on Vault Dike.

The settlement and tension cracks observed in 2013 and 2014 on the upstream side within the thermal cap of Bay-Goose Dike were still visible but are no longer active. The water pond at the downstream toe and the seepage downstream of Bay-Goose Dike and into Bay-Goose Pit should continue to be monitored. North Channel, Channel 1, and Channel 3 should be carefully monitored as the instrumentation or field observations seem to indicate that seepage could be occurring at these locations but is directly reported to the Pits instead of the downstream toe of the dike. Further assessment of the impact of Portage Pit mining on the performance of Bay-Goose Dike is underway as the North Channel piezometer seems to react to E3/E4 mining activity. The seepage from Central Channe should continue to be monitored.

At the time of the inspection and based on the instrumentation data, the TSF structures were generally in good condition. The tailings beach was adequate against the majority of the structure. Water was observed directly ponding against portions of Central Dike. AEM is closely monitoring the formation of a tailings beach against the peripheral structure of the TSF. Water was observed on the downstream side of Saddle Dam 2 ponding within the rockfill embankment. It is recommended to install a thermistor in that area and to be on the lookout for changes in the thermal regime of the foundation. A small hole in the bituminous membrane and a punctured water balloon were observed in the liner at Stormwater Dike and were repaired after the inspection per AEM.

Several tension cracks associated with movement were observed in an area of the Stormwater Dike crest. These movements appeared in August 2016 shortly after water from the South Cell started reaching this sector at the toe of the dike and stabilized shortly after a rockfill buttress was constructed at the toe of the dike in the South Cell. The movements observed are happening in a sector where the dike was built on frozen soft sediment and were probably caused by the water thawing this soft layer. The Meadowbank Dike Review Board (MDRB) recommended that additional instruments be installed, in order to get a better understanding of the foundation



through a geotechnical investigation and to establish design criteria for the mitigation measure put in place. In the meantime, it is recommended to keep monitoring potential movement on Stormwater Dike.

A water pond is accumulated on the downstream side of the Central Dike. This pond is feeded by an underground seepage that is connected to some extent to the South Cell. At the time of the inspection, the water was clear and an average flow of approximately 550 m³/hr was pumped back to the South Cell to maintain the downstream pond at El. 115 m. AEM is working closely with the MDRB and the dike designer (Golder) to determine the seepage pathway and to establish measures to keep the situation under control. Golder recommends: 1) maintaining a tailings beach against Central Dike; 2) controlling the hydraulic gradient by proper management of South Cell water pond and dike downstream toe pond; 3) closely monitoring the water quality; and 4) inspecting the structure.

No geotechnical issues were identified with the culverts along the AWPR. It is recommended to pay particular attention to culverts R-00A, 5+700, PC-14 and PC-16. If insufficient capacity to handle the flows is observed at freshet, then it is recommended to clear the obstructions or repair the culverts. It is also recommended to monitor the progression of the erosion of culverts at freshet at PC-17A, R14, R18-B, R20, R23 and R24 as there are signs that water is flowing beneath the road at these locations. If the erosion condition continues to deteriorate at these culverts, it is recommended to repair them. The bridges along the AWPR were in good geotechnical condition. Signs of settlement were observed at Bridge 6, R15. The bridge was dipping toward the western side on both abutments. The bridge foundation did not show any signs of adverse conditions. No remediation work is recommended for the moment, but the situation should be monitored.

It has been observed that most quarries had been cleaned since the 2015 inspection. Presence of unstable blocks and loose rocks along steep walls were still observed in Quarries 3, 7, 9, 16 and 23. It is recommended that workers be cautious in these quarries and be made aware of the potential hazard.

No geotechnical issues were observed with the Meadowbank Vault fuel tank. Water was observed ponding in several areas at the Baker Lake fuel tank farm and at the Meadowbank Main Camp fuel tank. Ongoing removal of fluids that accumulated within the secondary containment facilities should be managed to minimize the amount of water in contact with the tank bases. At the Baker Lake fuel tank farm, the granular fill protecting the geomembrane was eroded, thus exposing the geomembrane all along the south side of Tanks 3 and 4 and on the west side of Tank 1. A hole in the exposed geomembrane was also observed on the south side of Tank 3. It is recommended to repair the geomembrane and to re-cover the area with fill material. At the Meadowbank Main Camp fuel tank, a 3 m long tension crack was observed on top of the subexcavated area behind the fueling station.

It is recommended to monitor at freshet the performance of the five culverts installed on Vault Road, as three of them are partially collapsed in the middle. One of them had an entirely obstructed inlet and one of them had a partially obstructed outlet.

It is important that the diversion ditch and its erosion protection structure and sediment barriers be inspected during the next freshet season.

The diffuser at Wally Lake moved due to ice to a shallow location and as a result water was spraying out in the air. It is recommended to repair this diffuser so that the pipe is entering the lake. No geotechnical concerns were identified with the diffusers, landfill, landfarm, Stormwater Management Pond, nor the airstrip.



Study Limitations

Golder Associés Ltée (Golder) has prepared this document in a manner consistent with that level of care and skill ordinarily exercised by members of the engineering and science professions currently practising under similar conditions in the jurisdiction in which the services are provided, subject to the time limits and physical constraints applicable to this document. No warranty, express or implied, is made.

This document, including all text, data, tables, plans, figures, drawings and other documents contained herein, has been prepared by Golder for the sole benefit of Agnico-Eagle Mines Ltd. It represents Golder's professional judgement based on the knowledge and information available at the time of completion. Golder is not responsible for any unauthorized use or modification of this document. All third parties relying on this document do so at their own risk.

The factual data, interpretations, suggestions, recommendations and opinions expressed in this document pertain to the specific project, site conditions, design objective, development and purpose described to Golder by Agnico-Eagle Mines Ltd., and are not applicable to any other project or site location. In order to properly understand the factual data, interpretations, suggestions, recommendations and opinions expressed in this document, reference must be made to the entire document.

This document, including all text, data, tables, plans, figures, drawings and other documents contained herein, as well as all electronic media prepared by Golder are considered its professional work product and shall remain the copyright property of Golder. Agnico-Eagle Mines Ltd. may make copies of the document in such quantities as are reasonably necessary for those parties conducting business specifically related to the subject of this document or in support of or in response to regulatory inquiries and proceedings. Electronic media is susceptible to unauthorized modification, deterioration and incompatibility and therefore no party can rely solely on the electronic media versions of this document.



Table of Contents

1.0 INTRODUCTION.....	1
1.1 Scope Limitations	2
2.0 DEWATERING DIKES.....	2
2.1 East Dike	2
2.2 South Camp Dike	4
2.3 Bay-Goose Dike	4
2.4 Vault Dike	6
3.0 TAILINGS STORAGE FACILITY.....	7
3.1 General Observations of the Tailings Facility	8
3.2 Saddle Dam 1 – North Cell	8
3.3 Saddle Dam 2 – North Cell	9
3.4 Stormwater Dike – Divider Dike	10
3.5 Saddle Dam 3, Saddle Dam 4 and Saddle Dam 5 – South Cell	11
3.6 Central Dike – South Cell	12
4.0 GEOTECHNICAL INSTRUMENTATION.....	14
4.1 East Dike	14
4.1.1 Piezometers	14
4.1.2 Thermistors	16
4.1.3 Inclinometers.....	18
4.1.4 Seismograph.....	18
4.1.5 Flow Meters	18
4.2 South Camp Dike	18
4.3 Bay-Goose Dike	19
4.3.1 Piezometers	19
4.3.2 Thermistor.....	23
4.3.3 Inclinometers.....	24
4.3.4 Seismograph.....	24
4.3.5 Flow Meters	25
4.4 Vault Dike	25



2016 ANNUAL GEOTECHNICAL INSPECTION MEADOWBANK GOLD MINE, NUNAVUT

4.5	TSF South Cell	25
4.5.1	Central Dike	25
4.5.1.1	Thermistors.....	26
4.5.1.2	Piezometers.....	26
4.5.1.3	Seismograph	28
4.5.1.4	Turbidity and Water Quality	28
4.5.2	Saddle Dam 3	28
4.5.3	Saddle Dam 4	29
4.6	TSF North Cell.....	29
4.6.1	Saddle Dam 1	29
4.6.2	Saddle Dam 2	29
4.6.3	RF1-RF2	30
4.6.4	North Cell Tailings.....	30
4.7	Stormwater Dike	31
5.0	ALL-WEATHER PRIVATE ROAD.....	31
5.1	Culverts	32
5.2	Bridges	33
6.0	QUARRIES	39
7.0	BULK FUEL STORAGE FACILITIES.....	40
7.1	Baker Lake Tank Farm	40
7.2	Meadowbank Tank Farm (Main Camp)	41
7.3	Meadowbank Tank Farm (Vault Pit Area).....	41
8.0	OTHER MEADOWBANK FACILITIES	41
8.1	Site Roads	42
8.2	Diversion Ditches and Sediment and Erosion Protection Structure	42
8.3	RSF Till Plug.....	43
8.4	Diffusers	43
8.5	Landfill	43
8.6	Contaminated Soil Storage and Bioremedial Landfarm Facility.....	43
8.7	Stormwater Management Pond	44
8.8	Airstrip	44



9.0 SUMMARY AND RECOMMENDATIONS 44

9.1 Dewatering Dikes 44

9.2 Tailings Storage Facility..... 46

9.3 All-Weather Private Road 47

9.4 Quarries..... 48

9.5 Bulk Fuel Storage Facilities 48

9.6 Other Meadowbank Facilities 48

10.0 CLOSURE 50

11.0 REFERENCES..... 51

TABLES

Table 1: Malfunctioning Instruments on East Dike flagged by AEM 15

Table 2: Malfunctioning Instruments on Bay-Goose Dike flagged by AEM 19

Table 3: Observations on the Piezometer Readings of Central Dike 27

Table 4: Inspection of the Facilities along the All-Weather Private Road 35

FIGURES

- Figure 1: Meadowbank Mine Site
- Figure 2A: All-Weather Private Road
- Figure 2B: All-Weather Private Road
- Figure 2C: All-Weather Private Road

APPENDICES

APPENDIX A

Dewatering Dikes

APPENDIX A1

East Dike Photographic Log and Record of Inspection

APPENDIX A2

South Camp Dike Photographic Log and Record of Inspection

APPENDIX A3

Bay-Goose Dike Photographic Log and Record of Inspection

APPENDIX A4

Vault Dike Photographic Log and Record of Inspection

APPENDIX B

Tailings Storage Facility

APPENDIX B1

Tailings Facility Photographic Log



APPENDIX B2

Saddle Dam 1 Photographic Log and Record of Inspection

APPENDIX B3

Saddle Dam 2 Photographic Log and Record of Inspection

APPENDIX B4

Stormwater Dike Photographic Log and Record of Inspection

APPENDIX B5

Saddle Dam 3 Photographic Log and Record of Inspection

APPENDIX B6

Saddle Dam 4 Photographic Log and Record of Inspection

APPENDIX B7

Central Dike and Saddle Dam 5 Photographic Log and Record of Inspection

APPENDIX C

Geotechnical Instrumentation Data

APPENDIX C1

Dewatering Dikes Instrumentation Data

APPENDIX C2

TSF South Cell Instrumentation Data

APPENDIX C3

TSF North Cell Instrumentation Data

APPENDIX D

All-Weather Private Road

APPENDIX D1

Culverts Photographic Log

APPENDIX D2

Bridges Photographic Log

APPENDIX E

Quarries Photographic Log

APPENDIX F

Bulk Fuel Storage Facilities

APPENDIX F1

Baker Lake Tank Farm Photographic Log

APPENDIX F2

Meadowbank Tank Farm Photographic Log

APPENDIX F3

Vault Tank Farm Photographic Log

APPENDIX G

Other Site Facilities

APPENDIX G1

Vault Road Culverts Photographic Log

APPENDIX G2

Diversion Ditch and Sediment and Erosion Control Structure Photographic Log

APPENDIX G3

RSF Till Plug Photographic Log



2016 ANNUAL GEOTECHNICAL INSPECTION MEADOWBANK GOLD MINE, NUNAVUT

APPENDIX G4

Diffusers Photographic Log

APPENDIX G5

Landfill Photographic Log

APPENDIX G6

Contaminated Soil Storage and Bioremedial Landfarm Facility Photographic Log

APPENDIX G7

Stormwater Management Pond Photographic Log

APPENDIX G8

Airstrip Photographic Log



1.0 INTRODUCTION

Agnico-Eagle Mines Limited's (AEM) Meadowbank Division mandated Golder Associés Ltée (Golder) to conduct the 2016 annual geotechnical inspection, pursuant to the requirement of Type A Water Licence Permit No. 2AM-MEA0815 for the Meadowbank Gold Project, Nunavut.

Under Part I, Item 12 (pages 23 and 24), AEM is required to undertake an annual geotechnical inspection of its facilities between the months of July and September. The following structures were covered by the inspection:

- Dewatering dikes (East Dike, South Camp Dike, Bay-Goose Dike and Vault Dike);
- Tailings storage facility (Stormwater Dike, Saddle Dam 1, Saddle Dam 2, Saddle Dam 3, Saddle Dam 4, Saddle Dam 5 and Central Dike);
- Reclaim pond and South Cell pond;
- Geotechnical instrumentation;
- All-Weather Private Access Road (AWPR) and site roads (in particular culverts and bridges at water crossings);
- Quarries on site and along the AWPR;
- Landfill and contaminated soil storage and bioremedial landfarm facility;
- Bulk fuel storage facilities at the mine site and in Baker Lake;
- Shoreline protection and diffusers;
- Sediment and erosion control structures;
- Other structures: sumps, airstrip, RSF till plug, Stormwater pond, diversion ditch.

The 2016 geotechnical inspection was conducted from September 8 to September 15, 2016, by Yves Boulianne, a professional geotechnical engineer from Golder. During the inspection, the weather was overcast with daily temperatures varying between 5°C and 10°C. The inspection was scheduled at the time of year when the seasonal depth of thaw (active layer) is expected at, or near its maximum. Surface water flow is generally low to moderate at this time of year. Peak water flows typically occur during the spring thaw (mid-June through mid-July).

This report describes the geotechnical aspects of the areas inspected and presents general observations and recommendations.

Figure 1 shows the main mine site area. At the time of the inspection, the structures of the South Cell of the Tailings storage facility (Central Dike, Saddle Dams 3, 4 and 5) were being raised to El. 143 m and tailings deposition was ongoing in the South Cell from the south side of Central Dike.

An external review board, the Meadowbank Dike Review Board (MDRB), periodically meets to review dike designs, construction activities, as-built information and other geotechnical aspects of the project. The MDRB members were present on site in September after the 2016 annual geotechnical inspection.



1.1 Scope Limitations

The scope of the inspection is limited to the geotechnical aspects of each of the facilities listed in Section 1.0 above. The inspection did not include other assessments such as structural, mechanical or environmental.

For additional information related to the limitations of this scope, reference should be made to the Study Limitations provided at the beginning of this report.

2.0 DEWATERING DIKES

The dewatering dikes at Meadowbank include: East Dike, South Camp Dike, Bay-Goose Dike and Vault Dike. East Dike has been in operation since the dewatering of the northwestern arm of Second Portage Lake was completed in 2009. Bay-Goose Dike and South Camp Dikes became operational in July 2012 when the dewatering of the Bay-Goose Basin was completed. Construction of Vault Dike was completed in March 2013 and phase 2 of the dewatering of Vault Lake was completed in 2014.

The most current versions of the Operation, Maintenance and Surveillance (OMS) Manual (AEM, 2016a), and of the overall Emergency Response Plan (ERP) for the mine (AEM, 2016c) are dated March 2016 and August 2016. The Emergency Preparedness Plan (EPP) is included within the OMS. It is good practice to review these documents each year to keep the information up to date, particularly the 24-hour contact name and phone number.

A detailed visual inspection of the dewatering dikes is performed by AEM at least once a month. The monthly inspection reports were reviewed as part of the annual inspection. Most of the instruments on East Dike and Bay-Goose Dike are connected to a system that automatically collects and transmits data every 3 hours. Data for all instruments can be visualized on the software (VDV) and are checked daily by the mine engineering team. A review of the instrumentation data for the dewatering dikes is presented in Section 4.0 of this report.

Figure A1 shows a plan view of East Dike, Figures A2-A3 show a plan view of South Camp Dike and Bay-Goose Dike, and Figure A4 shows a plan view of Vault Dike. These figures indicate the location of the photos taken and observations noted during the inspection.

2.1 East Dike

East Dike is located on the east side of Portage Pit, and isolates the northwestern arm of Second Portage Lake. Dewatering of the northwestern arm of Second Portage Lake allowed for the development of Portage Pit and the construction of the Tailings Storage Facility. At the time of the inspection, East Dike served as an access road to the northern portion of Bay-Goose Dike and had not been used as a haul road since 2011.

East Dike was constructed in the summer of 2008; grouting of the foundation and bedrock occurred in 2008 and during the first quarter of 2009. East Dike is approximately 800 m in length, and was constructed within Second Portage Lake prior to dewatering. It consists of a wide rockfill shell, with downstream filters and a soil-bentonite cut-off wall that extends to bedrock up to 8 m below lake level.



Instrumentation has been installed within East Dike and includes piezometers, thermistors, inclinometers, and flow meters. Survey monuments were removed from East Dike in the past as they have never been used. The location of the instrumentation is indicated in Appendix C1. The inclinometer at Sta. 60+195 was destroyed in the past and has not been replaced. Replacement of this instrument is not considered necessary; however, monitoring of East Dike should continue and, if anomalous conditions are observed, then replacing this inclinometer should be re-evaluated. Due to a technical problem with the datalogger, the piezometer and thermistor data from June 2016 to September 2016 are missing for the instruments located from 60+240 to 60+700. As a result, partial pore water pressure and temperature data are available during the thawing period of 2016. Refer to Section 4.1 for the analysis of the available East Dike instrumentation data.

At the time of the 2016 inspection, no signs of cracking, sloughing or settlement were observed on the structure (including the vicinity of the 2009 sinkhole near Sta. 60+472).

Three seepage zones were identified in the past near the downstream toe of East Dike (at Sta. 60+247, 60+498, and 60+575). The zones at about Sta. 60+247 and Sta. 60+498 each have a seepage collection sump with a pump connected to a year-round pumping system. At the time of the inspection, the seepage was being captured within these sumps. According to AEM, the zone at about Sta. 60+575 was practically dry all year until the end of August 2016 when enough flow was observed to be able to monitor it. No water was observed at the downstream toe at Sta. 60+575 during the 2016 annual inspection. No sign of new seepage on the ground surface or downstream was observed.

Seepage flow is measured by the flow meters installed in the two seepage collection sumps downstream of East Dike. The average flow measured during the year was around 550 m³/day with peak activity averaging approximately 600 m³/day during the summer of 2016. The measured flow is slightly decreasing compared to values from the past years. During the year, the water quality in the sump was monitored by the environment department every week during freshet. It was reported that the water was clear in the sumps and did not exceed the TSS criterion for turbidity. According to the procedure in place, the water is pumped in Portage Pit instead of being sent to Second Portage Lake when the TSS criterion is exceeded. This did not happen from September 2015 to September 2016.

During the geotechnical inspection, and based on the instrumentation data, the condition of East Dike generally appears stable, as:

- No visual signs of slope instability or erosion were observed on the upstream and downstream rockfill slopes.
- No visual signs of cracking or settlement were observed on the dike and along the cut-off wall alignment.
- Seepage rates, while higher than anticipated in the design, are stable and are controlled by the pumping system in place. The TSS criterion is low enough for the water to be released in Second Portage Lake.
- Freeboard is adequate.
- Instrumentation data: piezometric, thermal, seepage, and inclinometer data do not show deteriorating conditions (refer to Section 4.1). However the data transmission system must be repaired.

Appendix A1 contains a photographic log and the record of inspection form for East Dike.



2.2 South Camp Dike

South Camp Dike is located south of the plant site area and is used to connect the mainland to South Camp Island. South Camp Dike, in conjunction with Bay-Goose Dike, isolates a portion of Third Portage Lake (Bay-Goose Basin) that allowed the development of Goose Island Pit and the southern portion of Portage Pit. It covers a narrow channel, approximately 60 m wide, with shallow water depths ranging from 0.5 m to 1.0 m.

South Camp Dike was constructed between April and June of 2009. Additional thermal capping material and rockfill for the haul road was added to the dike in the winter of 2009-2010. South Camp Dike has a broad rockfill shell with a bituminous geomembrane liner installed on the upstream side. Compacted granular material mixed with bentonite was placed above the toe of the liner. The liner was installed on native frozen (permafrost) till material in a trench approximately 3 m to 5 m below the lakebed surface. At the time of the inspection, South Camp Dike was used as an access road to connect the southern part of Bay-Goose Dike, and the contractor's offices and equipment area with the mine facilities.

An ultramafic waste rock stockpile about 10 m high is located 20 m away from the downstream toe of the dike. The distance between South Camp dike and the waste rock dump is sufficient to allow a complete visual inspection of the downstream area of the dike. It is recommended to continue keeping the downstream toe of the dike clear to facilitate inspection. The downstream toe and slope area was in good condition.

Two thermistor strings are installed on the upstream side of the dike. The thermistor data indicate that the foundation of the dike remained frozen throughout the past summers (2009 to 2015). Refer to Section 4.2 for a detailed analysis of South Camp Dike instrumentation data.

No geotechnical issue or seepage was observed during the inspection.

Appendix A2 contains a photographic log and record of inspection form for South Camp Dike.

2.3 Bay-Goose Dike

Bay-Goose Dike is located within Third Portage Lake on the southern side of Portage Pit and encompasses the Goose Island Pit. Bay-Goose Dike, in conjunction with South Camp Dike, isolates a portion of Third Portage Lake (Bay-Goose Basin).

Construction of Bay-Goose Dike started in the summer of 2009. The earthworks component for the northern portion of the dike was mostly completed by early October 2009 and by October 2010 for the southern portion. Grouting of the foundation and bedrock occurred between March 2010 and July 2011. Jet grouting occurred in selected portions of the dike between October 2010 and May 2011. The first phase of dewatering Bay-Goose Basin was completed by mid-November 2011 and the second phase was completed in August 2012.

Bay-Goose Dike is approximately 2,200 m long and consists of a wide rockfill shell, with downstream filters and a cut-off wall. For the majority of the dike, the cut-off wall extends to bedrock and consists of soil-bentonite (SB) and/or cement-soil bentonite (CSB). For portions of the dike where the cut-off wall was not constructed to bedrock, jet grouting of the soil between the base of the cut-off wall and the bedrock was performed, thereby extending the low permeability element of the dike to the bedrock surface. The water depth beneath the dike is up to 9 m, with a maximum depth to bedrock below lake elevation upwards of 20 m.



Instruments to monitor and assess the dike's performance are installed on Bay-Goose Dike. The instrumentation includes piezometers, flow meters (water collection pipe and a plastic bucket), thermistor strings, and inclinometers. Every blast in the vicinity of the dike is monitored for blast vibration. Survey monuments were removed from Bay-Goose as they have never been used. Appendix C1 shows the location of the instrumentation on Bay-Goose Dike.

The tension cracks observed in 2013 and 2014 on the upstream side within the thermal cap (between Sta. 32+100 to 31+750 approximately) were still visible during the 2016 inspection but did not show signs of progression and were not active anymore. Settlement within the thermal cap and on the upstream side of the crest (from Sta. 32+100 to 31+950 approximately), ranging from 0.1 m to >1.0 m, was observed but did not show any additional sign of movement since previous years. These areas should continue to be closely monitored to make sure no aggravating conditions are developing.

Seepage channels and water accumulation were observed at the toe of the dike during the inspection (North Channel, Central Channel, Central Shallows and Channel 3). There is currently no downstream seepage collection system at the downstream toe of the dike as the amount of seepage reporting downstream is currently too small to require such a system. Part of the seepage seems to be reported to the pits. Flow from these channels is monitored by various stations. At the time of the inspections, stations 6, 7, 8 and 9 were active and no turbidity was observed in the water at the downstream toe. From July to September 2016, the total average flow due to seepage from the toe of the dike was measured at 24 m³/day compared to 29 m³/day in 2015, 132.2 m³/day (1.5 L/s) in 2013, and 97.2 m³/day (1.22 L/s) in 2012. The measured flow in 2016 and 2015 does not take into account the inflow of water from the pond at Central Channel as this value was not measured in 2016 and 2015 (61 m³/day in 2013 and 2014). The overall seepage is stable and less than anticipated, and is thus currently not a concern. It is recommended to continue monitoring the evolution of the seepage at the toe of the dike and to continue measuring the inflow of water from the pond at Central Channel. Water was observed flowing in the North Channel during the inspection at Sta. 30+420 (observed flow of about 2.8 m³/day). According to AEM, water was observed ponding at the toe during the year. Due to the topography, it is possible that water is ponding in this area from a nearby seepage channel (i.e., near the northern abutment). The flow is being monitored by station no. 8 (30+420) and no. 9 (30+380) and has an average flow of 1.9 m³/day compared to 17 m³/day in 2015, 58 m³/day in 2013 and 80.8 m³/day in 2012. The sharp decrease of the flow recorded in 2016 could be caused by the seepage now reporting to Portage Pit E3/E4 instead of the downstream toe due to a connection between North Channel seepage and the nearby Pit E3/E4. The piezometers of the North Channel have shown response to the crest unloading that is part of the push back planned for extension of the pits E3 and E4 (see section 4.3.1 for more details). The Portage Pit expansion and its ongoing walls dewatering is being evaluated by AEM to determine the potential impact on the stability of Bay-Goose Dike. It is recommended to regularly inspect this area, monitor the flow of water, and be on the lookout for signs of seepage from the toe of the dike and in Pit E4.

Flow was observed into the Central Shallow seepage channel during the inspection at Sta. 30+625 and 30+655 (approximately 1.4 m³/day). The flow is being monitored by station no. 7 and had an average flow of 11.5 m³/day in 2016 compared to 12 m³/day in 2015, 13.3 m³/day in 2013 and 18.9 m³/day in 2012. This is similar to historic trends.

A water pond formed by the Central Channel seepage was observed downstream at Sta. 31+125. The mine pumps this pond as needed. The inflow was not monitored in this area in 2016 and 2015. In 2013 and 2014, the inflow from this area was 61 m³/day. It is recommended to keep measuring the water inflow when pumping the water pond formed at Central Channel.



Water flow was observed at Channel 3 during the inspection at about 31+500 (approximately 4.3 m³/day). A drainage channel is dug into the ring road nearby to allow water to flow freely in the pit. This area is monitored by station no. 6, which recorded 9.3 m³/day in 2016. According to AEM, water has been reported to the pit from this location during the year.

A water pond was observed downstream at Sta. 31+750, between Channel 2 and Channel 1. This water pond is not considered seepage as its level never changes except at freshet and after rain events. It is recommended to visually inspect the pond periodically and, if the level changes, to monitor water flow.

Channels 1 and 2 were not active at the time of the inspection. An accumulation of water was observed further downstream against Goose Pit ring road. According to AEM, water is observed downstream in that area during freshet season and naturally drains to Goose pit without reaching the dike toe. The instrumentation near Sta. 32+000 (Channel 1) indicates a potential seepage zone in that area. It is probable that seepage occurs at this location but reports directly to the pit. The instrumentation at this location needs to be closely monitored for changing trends.

During the inspection, it was observed that an inflow of water was still reported to Goose Pit and that some of the pit walls were wet. These observed water inflows were near Channel 1, Channel 2, and Channel 3 and are not being monitored anymore.

From the visual inspection and based on the instrumentation data, the performance of Bay-Goose Dike is satisfactory, as:

- No visual signs of slope instability or erosion were observed on the upstream and downstream rockfill slopes;
- The settlement and sloughing observed in the thermal cap and in the upstream side of the crest are stable and are no longer active;
- Freeboard is adequate;
- Instrumentation data: piezometric, thermal, seepage, and inclinometer data do not show deteriorating conditions (refer to Section 4.3).

Appendix A3 contains a photographic log and the record of inspection.

2.4 Vault Dike

Vault Dike is located across a shallow creek that connects Wally Lake and Vault Lake, at the Vault Pit area. Vault Dike was designed and constructed as a zoned rockfill dam with filter zones and an impervious upstream liner consisting of a bituminous membrane. The dike has an upstream key trench made of aggregate mixed with bentonite. The construction of Vault Dike was done in the winter of 2013 to keep its foundation frozen.

The settlement and cracks observed in 2013 and 2014 were not noticeable anymore. No geotechnical concerns were identified and Vault Dike was in good condition.

Five thermistor strings are installed on Vault Dike and are operational. One thermistor (TH-3) had been damaged by sloughing in previous year and stopped working in October 2015. Data are collected every 3 days and show that the foundation of the dike is frozen. Refer to Section 4.4 for a more detailed analysis of the instrumentation data on Vault Dike.



Appendix A4 contains a photographic log and record of inspection form for Vault Dike.

3.0 TAILINGS STORAGE FACILITY

The tailings storage facility (TSF) is located within the dewatered portion of the northwestern arm of Second Portage Lake and consists of the North Cell and the South Cell. The North Cell is being progressively closed while the South Cell is operational and is being progressively constructed as additional capacity to store tailings is required. Stormwater Dike is an internal structure separating the North Cell from the South Cell. A plan view of the TSF is shown on Figure 1.

The TSF was commissioned in conjunction with the mill start-up in February 2010, with tailings being deposited within the North Cell of the facility. The North Cell and internal structures (Saddle Dam 1, Saddle Dam 2, Stormwater Dike) were constructed to El. 150 m in two Stages from 2009 to 2011. Tailings deposition was transferred from the North Cell to the South Cell at the end of 2014. Tailings deposition occurred during the summer of 2015 within the North Cell and resumed in the South Cell in October 2015. Progressive closure of the North Cell started in the winter of 2015 with the construction of a non-acid generating rockfill capping over the tailings and continued in the winter of 2016. Water is transferred as needed from the North Cell to the South Cell to control the water elevation of the North Cell.

The construction of the South Cell started in 2012 with Central Dike, thereby closing the eastern portion of the South Cell. The beginning of the tailings deposition in the South Cell started at the end of 2014. From 2012 to 2016, Central Dike was raised to El. 143 m in four stages. To increase the capacity of the South Cell, additional peripheral structures (Saddle Dam 3, Saddle Dam 4 and Saddle Dam 5) were constructed to El. 143 m in two stages from 2015 to 2016. The South Cell is designed to be able to be raised to El. 150 m. The construction of subsequent portions of the South Cell will occur in the future if additional capacity is required.

A retention basin and a series of diversion ditches surround the catchment basin of the North Cell. These structures are designed to convey surface water runoff away from the TSF. Since 2014, the Western Diversion Ditch is collected within a retention basin prior to being pumped within the North Cell. This is due to a turbidity problematic from the erosion of the side slope and the crest of the ditches. Refer to Section 8.2 for the inspection of these diversion structures.

In the summer of 2014, the mine constructed an engineered tailings barrier along RF1 and RF2 to mitigate piping of tailings through RF1 and RF2. Refer to Section 8.3 for the inspection of this structure.

The most current versions of the Operation, Maintenance and Surveillance (OMS) Manual (AEM, 2016b), including the Emergency Preparedness Plan (EPP), and of the overall Emergency Response Plan (ERP) for the mine (AEM, 2016c) are dated March 2016 and August 2016. It is good practice to review these documents each year to keep the information up to date, particularly the 24-hour contact name and phone number.

An inspection of the TSF is performed once a month by AEM. The instruments are manually read twice a week during the summer and once a week during the winter. The monthly inspection reports were reviewed as part of the annual inspection. A summary of the instrumentation data obtained from the TSF is presented in Sections 4.5, 4.6 and 4.7 and in Appendices C2 and C3.

Figure B1 shows a plan view that indicates the location of the pictures and general observations related to the North Cell and South Cell. Figures B2, B3 and B5 contain a plan view that shows the location of the photos and



observations noted on Saddle Dam 1, Saddle Dam 2 and Saddle Dam 3. Figure B4 contains a plan view that shows the location of the photos and observations noted on Stormwater Dike. Figures B6-B7 contains a plan view that shows the location of the photos and observations noted on Central Dike, Saddle Dam 5 and Saddle Dam 4.

3.1 General Observations of the Tailings Facility

Per the TSF design, a tailings beach must be present at all times against all peripheral structures.

At the time of the inspection, the pond of water in the North Cell was located towards the centre of the facility and there was a tailings beach against the peripheral structures to protect them from ice in the winter and to prevent the migration of water out of the TSF (see Figure 1 for an approximate location of the tailings beach). The tailings elevation in the North Cell was around El. 149.5 m and the pond elevation was at 147.9 m approximately. The tailings beach against the structure of the North Cell was adequate.

At the time of the inspection, the pond elevation in the South Cell was at 130.9 m and the tailings elevation varied approximately between 132.5 and 128 m. Water in the South Cell was ponding against the entirety of the downstream toe of Stormwater Dike and against the northern portion of Central Dike (from Sta. 0+275 to 0+550 approximately) as tailings deposition was done from the south side of Central Dike during the construction of the South Cell in the summer of 2016. At the end of the construction season, tailings deposition resumed on the north side of Central Dike to restore the tailings beach before winter. AEM is closely monitoring the formation of a tailings beach against the peripheral structures and is monitoring the compliance of the tailings deposition with the deposition plan.

During the inspection, a rockfill berm was being constructed at the toe of Stormwater Dike in the South Cell (from Sta. 10+300 to Sta. 10+750) to mitigate the crest and downstream slope movement observed in this sector at the end of August 2016. The movements observed were probably caused by the soft sediment foundation thawing due to the South Cell water pond reaching the structure during the summer. Additional details about this situation are given in Section 3.4. Water ponding against Stormwater Dike is part of the tailings deposition plan and was acceptable as Stormwater Dike is not a peripheral structure. It is still possible to have water ponding against Stormwater Dike in the South Cell if the movement mechanisms are well understood.

At the time of the inspection, Saddle Dam 3, Saddle Dam 4 and Saddle Dam 5 were not operational as tailings were not deposited from these structures and the South Cell pond had not yet reached the upstream toes of these structures. Permanent sumps have not yet been installed on the downstream side of these structures and water accumulation is pumped as required. It is important that the water level on the downstream side is not allowed to raise higher than the granular layer of the upstream toe liner tie-in to prevent uplifting of the geomembrane.

Appendix B1 contains a general photographic log of the TSF's North Cell and South Cell.

3.2 Saddle Dam 1 – North Cell

Saddle Dam 1 is located in the northwestern corner of the TSF and forms one of the perimeter structures of the North Cell intended to retain tailings and supernatant fluid during the operation and the closure of the TSF. Saddle Dam 1 crosses a depression between the northwestern arm of Second Portage Lake and Third Portage Lake.

Saddle Dam 1 is a rockfill embankment with an 3H:1V upstream slope and a 1.3H:1V downstream slope. This structure has inverted base filters, upstream graded filters, and a linear low density polyethylene (LLDPE) geomembrane liner on the upstream dike face. The geomembrane liner is placed between an upper and lower non-woven geotextile layer for protection, and is covered by approximately 0.3 m of granular material up to El.



140 m. No granular layer was placed above El. 140 m and the liner is exposed above that elevation. According to the design, a tailings beach has to be maintained on the face of the structure to reduce the potential for ice damage to the liner. The abutments are founded on bedrock, while the central portion of the dike is founded on ice-poor soil. Till and/or crushed aggregate mixed with dry bentonite powder have been placed above the toe of the liner.

Stage 1 of Saddle Dam 1 was constructed in the fall of 2009 to a height of 10 m (crest elevation of 141 m) and a length of 250 m. Stage 2 was constructed in 2010 to an overall height of 20 m (final crest elevation of 150 m) and length of about 400 m.

Four thermistor strings are installed on Saddle Dam 1 and are manually read. Three thermistors (T1, T2, T3) are installed to monitor the thermal condition within the structure and its foundation, and were installed in 2009 and early 2010 as part of Stage 1. The fourth thermistor string (T4) was installed in 2009 and extended in 2010 along the upstream face of the dam to monitor the thermal condition of the tailings. The location of the instrumentation is shown in Appendix C3. Refer to Section 4.6.1 for the analysis of the instrumentation data.

During the inspection, it was observed that Saddle Dam 1 is performing well and does not show any geotechnical concern. An adequate tailings beach was observed along the upstream face of Saddle Dam 1.

A permanent dewatering sump is installed downstream within a sea-can container. Water was observed ponding near the sump. The environment department is monitoring the water quality during the year and this information is shared with the engineering department. The water quality results indicate that the water is not seepage from the North Cell. During the last MDRB, the Board members suggested to remove this pumping system and to backfill the toe drain trench to allow natural drainage of the water toward Third Portage Lake. Their opinion is that the foundation of Saddle Dam 1 is now frozen and therefore the weight of tailings will preclude any liner heave. Golder agree with this recommendation and recommend that the monitoring of the instrumentation on this sector continue and to reassess the situation if needed.

Appendix B2 contains a photographic log and the record of inspection form for Saddle Dam 1.

3.3 Saddle Dam 2 – North Cell

Saddle Dam 2 is located along the western side of the TSF and connects to the western corner of Stormwater Dike. Along with Saddle Dam 1, it forms one of the perimeter structures of the TSF's North Cell which retain tailings and supernatant fluid during the operation and closure of the TSF. Saddle Dam 2 crosses a depression between the northwestern arm of Second Portage Lake and Third Portage Lake. Its construction and design is similar to Saddle Dam 1. Saddle Dam 2 has a maximum height of about 10 m and a crest length of 460 m.

The upstream foundation of the dike and abutments are primarily founded on bedrock; however, some portions of the structure, underneath the inverted filter, are founded on ice-poor soil. During construction, a thin layer of low permeability till was placed and compacted along the toe liner tie-in connection with bedrock. A thin layer of crushed aggregate (0-22 mm) mixed with dry bentonite powder was also placed under the thin layer of low permeability till in areas where open fractures were observed within the bedrock. The toe liner tie-in was then covered with till.

Four thermistor strings (T1, T2, T3, and T4) have been installed at Saddle Dam 2 to monitor the thermal condition within the structure and its foundation. The location of the instrumentation is shown in Appendix C3. Refer to Section 4.6.2 for the analysis of the instrumentation data.



During the inspection, it was observed that Saddle Dam 2 is performing well and does not show any geotechnical concern. An adequate tailings beach was observed against the upstream side of the structure.

During the inspection, water was observed ponding on the downstream side within the rockfill embankment (between Sta. 20+275 to Sta. 20+475 approximately). This water was also observed during the 2015 annual inspection and the instrumentations indicate that the foundation remain frozen. According to AEM, water has been ponding at that location for a long time

Appendix B3 contains a photographic log and the record of inspection form for Saddle Dam 2.

3.4 Stormwater Dike – Divider Dike

Stormwater Dike is an internal structure that subdivides the TSF into the North Cell and the South Cell within the dewatered northwestern arm of Second Portage Lake. Stormwater Dike can be considered as a temporary structure as it will no longer be operational at closure. In this document, the North Cell side is taken as upstream and the South Cell side as downstream.

Stormwater Dike is a rockfill embankment structure founded on lakebed soils. The upstream slope is approximately 3H:1V and the downstream slope is about 1.5H:1V. A bituminous geomembrane liner has been installed above the graded filters on the upstream face of the dike. Low permeability till was placed and compacted along the upstream toe of the dike, above the liner.

Stormwater Dike was progressively constructed. Stage 1 was constructed in 2009 to a height of 10 m (crest elevation of 140 m) and a length of 860 m. Stage 2 was primarily constructed in 2010 to an overall height of 18 m (crest elevation of 148 m) and length of about 1,060 m. A horizontal bench is present along the upstream face of the structure due to the connection of the 2009 and 2010 portions of the structure. The junction between the bituminous liner of Stormwater Dike and the LLDPE liner of Saddle Dam 2 was completed in 2011. The crest of Stormwater Dike was raised to 150 m in 2013.

The majority of the dike is seated on dense till from the former lakebed within the talik while the abutments are generally founded on bedrock. The foundation preparation of Stage 2 was completed in winter conditions. It was generally done above water except in an area where water ponding was present (between Sta. 10+500 and 10+750 approximately). This pond was located where the topography suggests that the soft lakebed sediment thickness may be greater than at other locations along the dike. Due to the presence of water, the ice crust was cracked with the excavator and only minimal foundation preparation was possible. As a results, most of the lakebed sediment probably remained in place in this area.

At the end of August 2016, during a routine inspection, AEM noticed tension cracks and signs of settlements on the crest of Stormwater dike between Sta. 10+500 to 10+750 approximately. After these observations were made, movement monitoring instruments were installed on the crest of the dike (2 extensometers, 3 prisms and 4 cracks monitoring stations). The crack system that suddenly developed in this area had a lateral and vertical component according to the monitoring equipment. Global movement from 90-117 mm was recorded over 8 days by the instruments installed across the crest in the area of concern. To mitigate against a possible foundation failure, a rockfill buttress support was constructed at the downstream toe of Stormwater Dike in the South Cell (from Sta. 10+300 to Sta. 10+700 approximately). After the completion of this buttress (following the annual inspection), the displacement at Stormwater Dike stabilized and then stopped.



During the annual inspection, the construction of the rockfill buttress at the downstream toe (in the South Cell) was ongoing from Sta.10+300 to Sta.10+750. Several tension cracks were observed on the crest from Sta. 10+500 to 10+750. The tension cracks were up to 12 mm wide and some were deeper than 1 m. Some of the cracks were located on the downstream side of the crest parallel to the dike axis while others were perpendicular to the dike. Some of the cracks were continuous for more than 30 m. The downstream toe of the dike was not visible as it had been covered by the South Cell pond since July 2016. While not much information is confirmed at the moment, it is known that the movement observed occurred in an area where the dike foundation was constructed through water in the winter while leaving lakebed sediments in place. The current interpretation of the situation is that the soft sediment foundation was frozen in the winter of 2010 while additional rockfill material continued to be placed over it until July 2010. The foundation freezing explains why no adverse settlement or soil failure was observed until the South Cell water level started reaching the toe of the structure in July 2016, which probably thawed the frozen soft soil foundation. The mechanism that caused the observed movement could be due to a foundation soil failure, the thawing of ice lenses or a combination of both. AEM is currently working to clarify the as-built recording and is working with the dike designer (Golder) to address the recommendations of the MDRB for this structure. These recommendations include a study to better understand the condition of the foundation through a geotechnical investigation and the installation of additional instruments. The MDRB also recommended establishing design criteria for the mitigation measure put in place.

A tailings beach was present against most of the upstream side of Stormwater Dike. A small accumulation of water (approximately 30 cm deep) was observed ponding against the upstream side from Sta. 10+550 to 10+925. This small accumulation of water against the dike is considered acceptable.

During the inspection, a punctured water balloon was observed in the bituminous geomembrane at Sta.10+380. This punctured balloon was repaired after the inspection. The water balloon phenomena in the geomembrane was observed in previous years on Stormwater Dike and on the Saddle dams; it is caused by water infiltration from the crest. It is recommended to continue puncturing holes in the liner to free the water and to repair it afterward as these balloons produce stress on the seams of the geomembrane.

A small hole in the bituminous geomembrane was observed at approximately Sta. 10+200 and was repaired after the inspection.

A single deep thermistor (T147-1) and a piezometer string (VWP 13265) were installed at the downstream toe of Stormwater Dike (within the South Cell). These instruments were broken in September 2016 during the construction of the buttress at the toe of Stormwater Dike within the South Cell. Refer to Section 4.7 for the analysis of the instrumentation data at Stormwater Dike including movement monitoring.

Appendix B4 contains a photographic log and the record of inspection form for Stormwater Dike.

3.5 Saddle Dam 3, Saddle Dam 4 and Saddle Dam 5 – South Cell

The South Cell of the TSF consists of four perimeter structures: Central Dike, Saddle Dam 3, Saddle Dam 4 and Saddle Dam 5. Saddle Dam 3 is located in the northwestern corner of the South Cell and will eventually merge into Saddle Dam 2. Saddle Dam 4 is located in the southwestern corner of the South Cell and will eventually merges to Saddle Dam 5 which merges with the southern end of Central Dike.

Saddle Dams 3, 4, and 5 are designed and constructed as zoned rockfill dams with filter zones, low permeability upstream liners, and upstream toe liner tie-in key trenches. The Saddle Dams 3, 4 and 5 cross-sections consist of a rockfill embankment, constructed from run-of-mine waste rock, placed in lifts and compacted. The upstream



faces are designed at a 3H:1V slope and the downstream faces are designed at a 1.5H:1V slope. The upstream faces of Saddle Dams 3, 4 and 5 are comprised of two granular filter zones and a polyethylene liner (LLDPE) extending along the upstream foundation. The filter zones meant to keep the tailings inside the facility in a case that the liner has a hole but mainly act as appropriate bedding for the liner. An upstream liner tie-in key trench excavated to bedrock and filled with compacted till is located along the upstream area of the structures. The bulk part of Saddle Dams 3, 4 and 5 consists of coarse rockfill material.

Stage 1 of Saddle Dam 3, 4 and 5 was constructed in 2015. During Stage 1, Saddle Dam 3 and 4 were constructed to El. 140 m and Saddle Dam 5 to El. 137 m. Stage 2 of Saddle Dam 3, 4 and 5 was constructed to El. 143 m in 2016. These structures are designed to be able to be raised to El. 150 m and the final crest elevation of these structures is subject to review by AEM. At the end of Stage 2, the decision was made by AEM to leave the abutments of these structures unfinished. This decision was made to make it easier to raise these structures by connecting to the existing layer. If these structures are not raised higher, it will be necessary to extend the liner and complete the abutment. The completed crest length is approximately 170 m for Saddle Dam 3, 260 m for Saddle Dam 4, and 150 m for Saddle Dam 5.

At the time of the inspection, the 2016 construction was winding down and these structures were not yet operational. The water level of the South Cell had not reached the upstream toe of these structures and they were not retaining tailings. These structures will become operational in 2017. No geotechnical issues were observed with these structures.

Thermistors are installed at Saddle Dam 3 and Saddle Dam 4. Refer to Sections 4.5.2 and 4.5.3 for the interpretation of the instrumentation data.

During the inspection, water was observed ponding in some areas of the downstream side of Saddle Dam 3 and Saddle Dam 4. As the downstream toe is higher than the South Cell pond, this water does not come from the TSF. It is important to maintain the water level on the downstream side lower than the level of the upstream toe liner tie-in granular material layer to prevent uplift of the geomembrane. As the elevation of the downstream side is lower than the elevation of the granular material, this should not be a problem if the downstream water level is managed.

Appendices B5 and B6 contain a photographic log and the record of inspection forms for Saddle Dams 3 and 4.

3.6 Central Dike – South Cell

Central Dike is located along the eastern side of the TSF and crosses a depression within Second Portage Lake. Along with Saddle Dam 4 and Saddle Dam 5, Central Dike forms one of the perimeter structures of the South Cell.

Central Dike design includes a compacted rockfill embankment with an upstream seepage barrier, granular filters and a key trench along the centreline of the dike transitioning on the upstream toe near both abutments. The foundation soils include lakebed sediments and till overlying bedrock. Soft and ice-rich soils were removed from the Central Dike footprint during construction.



Construction of Central Dike started in 2011. Central Dike was built to El. 143 m during the 2016 construction season (Stage 5). Central Dike is designed to be able to be raised to El. 150 m and the final crest elevation is subject to review by AEM. At the end of the 2016 construction season, the decision was made by AEM to leave the extremity of the north abutment unfinished. This decision was made to make it easier to raise the structure if needed by connecting to the existing layer. If Central Dike is not raised higher, it will be necessary to extend the liner and complete the northern abutment. The completed crest length is approximately 850 m.

Seepage into the basin at the downstream toe of Central Dike was observed when tailings deposition was transferred from the North Cell of the TSF to the South Cell in 2014. The rate of seepage started to increase proportionally to the rise of the pond level of the South Cell. Desktop studies were undertaken by Golder in 2015 to estimate the seepage flows and pore water pressures, verify the dike stability, and attempt to predict the eventual flow volume that would report to the downstream toe for higher pond elevation. The seepage pathway used in the Golder 2015 model was through a layer of fine material in the till layer of the foundation as it was deemed the most critical scenario for the structure stability. The main recommendation from this desktop study was to maintain beaches adjacent to Central Dike and to maintain a 'back pressure' on the downstream side of Central Dike in order to reduce the hydraulic gradient by holding the downstream pond at El. 115 m. Willowstick was also hired to carry out geophysical soundings to detect seepage paths. The geophysical campaign led to additional recommendations and identified possible seepage path locations. Following the geophysical investigation, an investigation was conducted by SNC Lavalin (SNC) and AEM in December 2015 at station CD-595, and between CD-810 and CD-850. Highly altered and fractured bedrock was encountered and high hydraulic conductivity was measured from Packer testing. Instrumentation of the four boreholes with piezometers and thermistances was done at the same time. In 2016, the MDRB recommended that the seepage model and stability analyses be updated. A study is currently underway to update the seepage modelling with a seepage flow through the bedrock.

At the time of the inspection, there was a tailings beach against the southern part of the structures and water was ponding against the upstream face on the north side from Sta. 0+275 to 0+550 (approximately 1 m deep). The deposition of tailings against the dike stopped in the summer during the construction of Stage 5 of Central Dike. The deposition of tailings against the northern part of Central Dike resumed after the extension of the tailings deposition finger in October 2016. AEM is planning on maintaining a proper tailings beach against the entire length of this structure during operation and closure as per the design requirements.

During the inspection, water was observed ponding at the downstream toe of the dike between approximately Sta. 0+300 and the southern access road at Sta. 0+830. The water was clear with no sign of turbidity. At the time of the inspection an average flow of approximately 550 m³/hr was pumped back to the South Cell to maintain the downstream pond at El. 115 m. No water inflow was reported to Portage Pit in 2016 from that location. AEM is working closely with the MDRB and the dike designer (Golder) to determine the seepage pathway and to establish measures to keep the situation under control. Golder recommends: 1) maintaining a tailings beach against Central Dike; 2) controlling the hydraulic gradient by proper management of South Cell water pond and dike downstream toe pond; 3) closely monitoring the water quality; and 4) inspecting the structure for changing conditions. Additional recommendations related to the downstream seepage situation will be issued by Golder following the study to update the seepage and stability analysis.

Nine boreholes were drilled on three different rows on Central Dike. The first row corresponds to the central key trench, the second row corresponds to the final downstream toe, and the third row corresponds to the Portage Pit limit. Four additional boreholes were drilled and instrumented on the first row during the geotechnical investigation



done by SNC in 2016. Piezometers and thermistor strings are installed in each of these boreholes (for a total of 47 piezometers and 13 thermistors). Two thermistors strings are also installed on the upstream face to monitor the temperature within the tailings of the South Cell. All instruments are read manually. The need for additional instrumentation is being reviewed as part of the study to update the Central Dike seepage model and stability analysis. The interpretation of the instrumentation data is provided in Section 4.5.1.

Appendix B7 contains a photographic log and the record of inspection form for Central Dike and Saddle Dam 5.

4.0 GEOTECHNICAL INSTRUMENTATION

As part of the 2016 geotechnical inspection, the dewatering dikes and TSF instrumentation data were reviewed. During the year, daily review of the instrumentation on the dewatering dikes is done by mine personnel and monthly reports summarizing their observations are issued internally. The compilation of the instrumentation data was not part of the scope of this study, and the figures showing the data were provided by AEM. The information provided by AEM is presented as received in Appendix C. The data were sent as figures for the dewatering dikes and as PowerPoint documents and Excel File for the TSF structures. Continued monitoring and review of instrumentation data is recommended.

4.1 East Dike

Instrumentation within East Dike was installed in the spring of 2009 to monitor the dike's performance following construction and during dewatering, operation, and into closure. Additional instrumentation was added in 2009 and 2010 to increase coverage across the dike. Since June 2012, all piezometers and thermistors on East Dike are connected to an automatic data collection and transmission system (VDV database). The following subsections present a summary of the data collected between September 2015 and September 2016.

Due to a technical problem with datalogger, the piezometer and thermistor data from June 2016 to September 2016 are missing for the instruments located from 60+240 to 60+700. As a result, partial pore water pressure or temperature data are available for East Dike during the thawing period of 2016.

Previous annual geotechnical inspection reports contain additional information regarding instrumentation data collected prior to September 2015. The 2016 instrumentation data for East Dike are presented in Appendix C1.

4.1.1 Piezometers

Three arrays of multilevel vibrating wire piezometers (VWP) were installed within East Dike in mid-March 2009 as follows:

- South Channel (Sta. 60+190)
- North Channel (Sta. 60+490)
- North Shallows (Sta. 60+700)

At each location, multilevel VWPs were installed:

- Upstream side of the cut-off wall, approximately 2 m from the centreline.
- Immediately downstream of the cut-off wall, approximately 2 m from the centreline.



- Further downstream of the cut-off wall, approximately 10 m from the centreline.

Single VWP's were also installed downstream of the cut-off wall near the contact area (base of cut-off wall and top of bedrock surface) at Sta. 60+150, Sta. 60+200, Sta. 60+240, Sta. 60+400, Sta.60+420, Sta.60+440, Sta. 60+450, Sta. 60+460, Sta.60+470 60+472, Sta. 60+480, Sta. 60+500, Sta. 60+510, Sta. 60+550, Sta. 60+600, Sta. 60+650, and Sta. 60+750.

Some of the installed piezometers on East Dike are broken or malfunctioning. Table 1 indicates the instruments flagged by AEM, the possible reason why it is malfunctioning, and the date when it started malfunctioning. The piezometers located at Sta. 60+150, 60+470 and 60+750 are broken and do not produce any pore water pressure data. The piezometers located at Sta. 60+550C, 60+650C, 60+700P1B and 60+700P2C are giving erratic data and reported as frozen by AEM. The data analysis indicates that these piezometers are in fact frozen. Piezometers 60+600C, 60+490P2C, 60+700P1A, 60+700P1C are also frozen and are giving widely fluctuating data. A piezometer that has frozen at some point cannot be relied upon. It is thus recommended to flag these piezometers and be very careful when interpreting their data.

Table 1: Malfunctioning Instruments on East Dike flagged by AEM

Name of Piezometer	Location	Possible Reasons for Malfunctioning	Malfunctioning Start Date
150-C	60+150	No reading, broken	November 2012
470-C	60+470	Pore water pressure reading broken, temperature still working	November 2009
550-C	60+550	Frozen, still shows head and temperature (erratic data)	November 2014
650-C	60+550	Frozen, still shows head and temperature	May 2016
700-P1B, 700-P2C	60+700	Frozen, still shows head and temperature	November 2014
750-C	60+750	Pore water pressure reading broken, temperature still working	April 2013

The piezometers data are showing that the pore water pressure is not increasing and is similar to the value recorded in the past with a long-term trend going towards a general decrease in the pore water pressure. However, the pore water pressure and temperature measurement for the piezometers at East Dike stop at the beginning of June 2016 (beginning of the thawing period). According to AEM, this is caused by a communication and/or datalogger issue and this is currently being investigated.

For the three piezometric arrays located at Sta. 60+190, Sta. 60+490, and Sta. 60+700, the following observations can be made. It must be reminded that these observations are not representative of the thawing season of 2016 .

- At Sta. 60+190, the observed levels are consistent with expectations for a functioning cut-off wall. There is a consistent drop in the hydraulic head across the cut-off wall and within the grouted bedrock in the downstream direction. Further downstream, the hydraulic head continues to decrease. There spike increases in the hydraulic head in September 2015, June 2016 and August 2016. These spikes are probably due to pumping interruption for maintenance. As observed in past years, no instruments froze in the winter and the temperature data indicates the presence of seepage. For example, the temperature reading at 190-P1-C



increased to approximately 6°C in September 2015. Then, the temperature decreased to approximately 0.6°C between October 2015 and June 2016 despite extremely cold air temperatures. If the temperature fluctuations at 190-P1-C were caused by changes in air temperature at the ground surface, then thermal responses in both summer and winter would be expected. Since the latter is not the case, it is highly probable that seepage water from the upstream side of the dike is responsible for the thermal behaviour. The recorded piezometric pressure decreases towards the downstream side and with elevation, which seems to indicate that flow is occurring towards the pit. Given the hydraulic head response consistent with the expectations of a functioning cut-off wall, it is reasonable to assume that the seepage water is originating from a different part of the dike.

- At Sta. 60+490, flow through the dike is observed as the piezometric pressure is very similar before and after the cut-off wall (490-P3-B vs 490-P2-B in particular). Sign of seepage are also observed in the thermal instrumentation data associated with this piezometric array. None of the instruments are frozen and there is a correlation between the lake temperature and the temperature recorded by the piezometric array at this location and the temperature data follow the same trend with very little offset. The aforementioned piezometric and thermal trends correspond to the seepage zone observed at Sta.60+498. The recorded piezometric pressure decreases towards the downstream side and with elevation, which seems to indicate that flow is occurring towards the pit.
- At Sta. 60+700 the majority of the piezometers are frozen. The remaining instruments show that the observed levels are consistent with expectations for a functioning cut-off wall. The temperature data are consistent with observations noted during the previous years and indicate mostly frozen conditions.

The following observations were also made for the single VWP:

Sta. 60+200 to 60+510

The temperature variations recorded by these piezometers show the same trends as Sta. 60+490 and Sta. 60+190. These piezometers have not frozen during the year and are showing temperature trends that can be correlated with the lake temperature. These piezometers are probably recording the effect of the seepage observed at Sta. 60+498.

4.1.2 Thermistors

Five thermistor strings having 16 nodes at 1 m interval have been installed on East Dike (at Sta. 60+092, 60+185, 60+485, 60+695, and 60+842).

The data sent by AEM covers the period from September 2015 to September 2016. No data are available for T485, T695 and T842 after June 2016. These string data starts converging toward a single value after June 2016. As a result, the thermistor string interpretation is incomplete between Sta. 60+485 and 60+842 and the maximum ground thermal regimes are not representative of the thawing period of 2016 (from June to September).

The instrumentation data for the September 2015 to June 2016 period are consistent with the historical trends.

These specific observations have been made for each instrument for the period analyzed:

Sta. 60+092 and Sta. 60+842

The thermistors installed at Sta. 60+092 and Sta. 60+842 are located on the southern and northern abutments. The upper 1 m of the dike of both abutments thawed in 2016 (active layer). From September 2015 to June 2016,



there has been little to no change in the ground thermal regime. Below El. 134 m, the cut-off wall remained frozen for these two thermistors. The temperature within the dike varied from 6°C to -16°C within the active layer of the dike, from -1°C to -12°C in the till, and from -2°C to -10°C in the bedrock. Fewer temperature variations were generally observed with depth at each location.

Sta. 60+185

The thermistor string installed in the South Channel at Sta. 60+185 (bedrock about 6 m below water surface at El. 127 m) recorded the following temperature variations:

- The upper layer of the cap material (from El. 136 m to El. 134 m) was thawed in September 2015 and was frozen during the winter period (active layer). The active layer shows significant fluctuations in temperature, going from 2°C to -11°C.
- The cut-off wall above the lake level and in the till from El. 133 to 127 m remained frozen, but very slightly below 0°C. In the past, it was observed that the portion between El. 133 m and El. 127 m remained frozen during the year. Very little to no change in the ground thermal regime has been observed from the incomplete data. This result may seem surprising, as potential seepage is inferred from the thermal behaviour at 190-P1-C at Sta. 60+190. However, 190-P1-C is further downstream from the dike and the lag between maximum 190-P1-C and the data seem to suggest that the water is originating from a different part of the dike structure closer to Sta. 60+490.
- The bedrock portion of the dike (below El. 127 m) remained thawed. The bedrock had a temperature variation between 0°C and 3.5°C increasing with depth.

Sta. 60+485

The thermistor string at Sta. 60+485, installed within the North Channel (bedrock at approximately El. 126 m, 7 m below lake level), indicated the following temperature variations:

- The upper portion of the cut-off wall located in the lake (from El. 136 m to El. 128 m) was in an active zone. Significant temperature fluctuations were recorded (10°C to -11°C).
- The cut-off wall below El. 128 m and the bedrock remained thawed during the year with significant variations in temperature (between 11°C and 0.1°C).

The thermal variation observed within the cut-off wall below El. 128 m and in the bedrock is significant with fluctuations between 11°C and slightly above 0°C. From September 2015 to June 2016, there is good correlation between recorded temperatures and the upstream lake temperatures, indicating advective flow through the dike (i.e., recorded temperature changes are primarily a result of temperature changes in water flowing through this area). The delay between changes in the recorded temperatures within the lake and within the cut-off wall is minimal. The temperature responses recorded in the piezometers at Sta. 60+490 P2 (A,B,C) and 60+490 P1 (A,B,C) are also significant, as are the responses recorded within the piezometers at Sta. 60+190-P1-C, Sta. 60+450, Sta. 60+460, Sta. 60+472, Sta. 60+480, Sta. 60+490, and Sta. 60+500. Seepage is being observed downstream and is collected in the sump and removed via the pumping system.



Sta. 60+695

The thermistor string installed in the North Shallow at Sta. 60+695 (bedrock at El. 128.5 m approximately, 4.5 m below upstream lake level) recorded the following temperature variations:

- The thermistor beads from El. 136 m to 130 m indicate that the upper portion of the cut-off wall was thawed in September 2015 and frozen during the winter (active layer). The recorded temperature variations are between 4°C and -14°C.
- The thermistor beads from El. 130 m to 128 m indicate that the cut-off wall and the till between these elevations remained frozen throughout the monitoring period, with temperature fluctuations between 0°C and -8°C.
- The temperature recorded in the bedrock varied between -0.5°C and 3°C increasing with depth. The temperature recorded at each node in the bedrock varied by approximately 1°C during the year.

4.1.3 Inclinerometers

Two inclinometers are installed on East Dike at Sta. 60+495 and 60+705. An inclinometer was installed at Sta. 60+195, but was destroyed in July 2010 and has not been replaced. The inclinometer displacements are referenced along Axis A and Axis B; Axis A is perpendicular to the cut-off wall alignment (positive displacements are towards the Pit side), while Axis B is parallel to the cut-off wall (positive displacements are towards the increasing chainage), perpendicular to Axis A.

Recorded displacements are small. The maximum cumulative displacements at the crest was observed in the inclinometer installed at Sta. 60+705. The cumulative displacement is about 25 mm perpendicular to the cut-off wall (Axis A), and 20 mm aligned to the cut-off wall (Axis B). The recorded displacements are well within the tolerable displacements for the structure and are not a concern.

4.1.4 Seismograph

No PVS measurements were taken in 2016 for East Dike as no blast occurred in the vicinity of East Dike.

4.1.5 Flow Meters

The flow at the downstream toe in 2016 was measured by the flow meters installed in the two seepage collection sumps downstream of East Dike. The average flow measured during the year by the flow meters was around 550 m³/day with peak activity having an average of approximately 600 m³/day during the summer of 2016. The measured flow is slightly decreasing compared to values from the past years. During the past year, the turbidity of the water in the sump meet the TSS criteria set for direct discharge into the Second Portage Lake.

4.2 South Camp Dike

Two thermistor strings are installed on the upstream side of South Camp Dike. SD-10 is located near the liner toe. SD-09-A is located approximately 20 m further upstream within Third Portage Lake. South Camp Dike thermistor data for September 2015 to September 2016 are presented in Appendix C1. Based on the thermistors data, no signs of seepage are evident and the recorded value follows historical trends.

The following summarizes the observations regarding the thermal regime at these locations:

- The temperature profile at SD-09 on the upstream side of the dike shows that the soils located beneath the dike foundation and liner have remained frozen (permafrost) below El. 128 m.



- The temperature profile at SD-10 shows that the foundation of the dike below the thermal cap stayed frozen all year long.

4.3 Bay-Goose Dike

Instruments were installed on Bay-Goose Dike in the summer of 2011 to monitor the dike’s performance following construction, during dewatering, operation, and into closure. At the time of the inspection, all the piezometers and thermistors on Bay-Goose Dike (except three thermistors) had an automatic data collection and transmission system to the VDV database. The following subsections present a summary of the data collected between September 2015 and September 2016. Data plots for the instrumentation sent by AEM are presented in Appendix C1.

4.3.1 Piezometers

Arrays of multilevel VWP’s were installed within Bay-Goose Dike as follows:

- Sta. 30+158 (1P)
- Sta. 30+276.5 (2P)
- Sta. 30+378.5 (3P)
- Sta. 30+453.5 (4P)
- Sta. 30+645.5 (5P)
- Sta. 31+165 (23P)
- Sta. 31+600 (24P)
- Sta. 31+815 (25P)
- Sta. 31+885 (26P)
- Sta. 32+000 (27P)
- Sta. 32+065 (28P)
- Sta. 32+105 (29P)

At each location, multilevel VWP’s were installed on the:

- Upstream side of the cut-off wall, approximately 2 m from the centreline;
- Immediately downstream of the cut-off wall, approximately 2 m from the centreline;
- Further downstream of the cut-off wall, approximately 10 m from the centreline.

In addition, single VWP’s were installed immediately downstream of the cut-off wall near the contact area (base of cut-off wall and top of bedrock surface) at the following stations:

- Sta. 30+167 (6P2)
- Sta. 30+249.5 (7P2)
- Sta. 30+306.5 (8P2)
- Sta. 30+440 (9P2)
- Sta. 30+516.5 (10P2)
- Sta. 30+684.5 (11P2)
- Sta. 30+770 (12P2)
- Sta. 30+804.5 (13P2)
- Sta. 31+052 (14P2)
- Sta. 31+220 (15P2)
- Sta. 31+565 (16P2)
- Sta. 31+615 (17P2)
- Sta. 31+700 (18P2)
- Sta. 31+842 (22P2)
- Sta. 31+928 (19P2)
- Sta. 31+990 (20P2)
- Sta. 32+020 (21P2)

Some of the installed piezometers on Bay-Goose Dike are broken or malfunctioning. Table 2 indicates the list of malfunctioning instruments on Bay-Goose Dike as flagged by AEM, the possible reason why they are malfunctioning, and the date when they started malfunctioning.

Table 2: Malfunctioning Instruments on Bay-Goose Dike flagged by AEM

Name of Piezometer	Location	Possible Reasons for Malfunctioning	Malfunctioning Start Date
1P1-C	30+158	Rapid freezing, piezometric head went off limits and broke the instrument (temperature still works)	February 22, 2013



2016 ANNUAL GEOTECHNICAL INSPECTION MEADOWBANK GOLD MINE, NUNAVUT

Name of Piezometer	Location	Possible Reasons for Malfunctioning	Malfunctioning Start Date
1P1A, 1P1-B	30+158	Frozen, still shows head and temperature	March 19, 2014
1P2-C	30+158	Frozen, still shows head and temperature	March 1, 2015
2P1-A, 2P1-B,	30+276.5	Frozen, still shows head and temperature	January 4, 2014
5P1-A, 5P1-B, 5P1-C, 5P2-C	30+645.5	Frozen, still shows head and temperature	February 8, 2014
6P2C	30+167	Frozen, still show head and temperature	March 1, 2015
10P2C	30+516.5	Frozen, still show head and temperature	February 17, 2015
11P2	30+684.5	Frozen, still shows head and temperature	February 27, 2015
12P2	30+770	Frozen, still shows head and temperature	January 17, 2013
13P2	30+804.5	Frozen, still shows head and temperature	December 20, 2012
14P2	31+052	Rapid freezing, piezometric head went off limits and broke the instrument (temperature still works)	February 21, 2012
15P2	31+220	Frozen, still shows head and temperature	February 4, 3013
16P2	31+565	Frozen, still shows head and temperature	January 15, 2013
17P2	31+615	Frozen, still shows head and temperature	February 2, 2014
18P2	31+700	Frozen, still shows head and temperature	February 2, 2014
29P1B2, 29P2B3,29P3B3, 29P2C	32+105	Frozen, still shows head and temperature	March 6, 2014
29P1B3	32+105	Frozen, still shows head and temperature	March 4, 2014



An analysis of the piezometer data indicates that the piezometers identified as frozen by AEM show temperatures below 0°C. In the instrumentation data sent by AEM, additional piezometers are flagged as being frozen (1P2-B, 2P2-C). It is recommended to add these piezometers to the monthly instrumentation report as potentially malfunctioning. The thermal data analysis for the piezometers also shows that piezometers 2P1-C, 7P2, 8P2, 23P1-C, 25-P1-B1, 25P1-B2, 27P1-B2, 29P1-B1 and 29P3-A1 might have frozen as they recorded data below 0°C. The piezometric reading of these piezometers is fluctuating while remaining within probable data range. This could be because the thermal calibration is slightly off and the piezometer did not really freeze, or it could mean that the piezometer froze and is broken but that has not reflected in the data. A piezometer that has frozen once may not be relied upon even if it unfroze. It is recommended to flag these piezometers to be careful when interpreting their data while staying vigilant to any rapid piezometric variance. The first time a piezometric rapid increase associated to a frozen piezometers is observed, it is important to remain vigilant without overweighting the abnormal trend. For the instruments showing very high piezometric readings, it is recommended to compare the pressure recorded to the instrument limit in order to identify if the variance could be due to factors other than mechanical problems such as seepage.

The majority of the instrumentation was installed at Bay-Goose from May to June 2011. The pumping of Goose Bay was done from July to November 2011. The response of the pumping of Goose Bay can be observed in most of the piezometers, with sharp decreases in pore water pressure (pwp) from July to November 2011.

A cooling trend starting in July 2012 can be observed in all piezometers installed on Bay-Goose dike. The instruments located farther on the downstream side generally record lower temperature than the instrument closer to the dike and the lake. As a result, the instruments on the upstream side of the dike are generally the last ones to freeze and the ones farthest on the downstream side are the first to freeze. In some sectors, most of the piezometers are in frozen condition, while in some sectors almost none of the piezometers are in frozen conditions. There seems to be a correlation between the sector in which seepage have been observed historically and the number of frozen instruments.

From 2012 to 2016, a generalized trend can be observed in the pore water pressure measurements of most non-frozen piezometers located along the dikes (upstream and downstream side). An increase in pore water pressure is observed during winter (November to May approximately). The pore water pressure tends to stabilize or decrease during freshet (May to September approximately). Historically, the rising trend has been attributed to ice build up at the downstream toe of the dike and the decrease has been attributed to melting of this ice.

There is generally a drop in the hydraulic head across the cut-off wall and within the grouted bedrock in the downstream direction. In general, the data from the piezometers are similar to the historical trend.

In addition to the seasonal trend described above, specific observation trends can be observed for various areas of the dikes. These areas generally coincide with seepage channels as the majority of piezometers are frozen in non-seepage channel areas.

North Portion (Sta. 30+158 to 30+516.5)

The majority of the multilevel piezometers installed at 30+158 are in frozen conditions. The thermistor downstream of the dike froze in 2015 at the time Goose Pit reached its final elevation. The upstream thermistor froze in 2016.

More than half the multilevel piezometers installed near 30+276.5 are frozen. The recorded pore water pressure (pwp) in the unfrozen instruments increased from November 2014 to April 2015 by approximately 0.6-1 m. The piezometric level has since then been constant with cyclical variation but has not recovered to the level before



2015. The unfrozen piezometers on the downstream side near the cut off wall had a 0.4 to 0.6 m cyclical fluctuation from March to September 2016.

Piezometers located near the North Channel from Sta. 20+378 to 30+453 have recorded an increasing trend in pwp from January 2013 to May 2016. This increase is more pronounced for the piezometer located on the downstream side (2.6 m approximately). A similar increase in pwp was recorded in the winter of 2012, but not in the winter of 2013 (1.6 m approximately). During the 2013 freshet the pwp levels have not dropped back to the freshet 2012 level (0.4 m higher) and have continued to increased until the freshet of 2016. In May 2016, a sudden drop of pwp was recorded in most instruments of the North Channel (up to 2 m). The furthest piezometer installed downstream at 30+453 recorded a huge pressure spike during winter 2016 (6 m increase), which had a similar drop during the freshet.

These variation in pore water pressure are happening in the zone associated with the North Channel seepage and monitored by seepage station no. 8 and no. 9. The increase in magnitude of the pore water pressure until May 2016 and their sudden decrease might be caused by the mining activity and the depressurisation of the rock walls for the expansion of Pit E3/E4. From 2016 to 2015, a sharp decrease in flow reporting at the downstream toe of this sector was also observed in the monitoring stations, which supports this theory. A large catch bench in Pit E4 near the north sector of Bay-Goose Dike was blasted from December 2015 to May 2016. Within this catch bench, 30 holes were drilled to depressurise the pit wall. The depressurisation activities were not continuous and the system froze regularly in the winter, which may explain the cyclical fluctuation of the pore water pressure in the downstream piezometer in this sector.

The temperature recorded by the piezometer from Sta. 30+150 to Sta. 30+276.5 shows various spikes in temperature from July to September 2016. The average spike varies from 0.2 to 0.4°C. In 2014, similar spikes occurred in the same instruments during the month of July. All the beads of thermistor strings T1 (30+134) and T2 (30+185) also show wide fluctuation of temperature (5 to 10°C) during the month of July that then stabilized. What caused these quick temperature fluctuations at this location is not understood; there might be a problem with the instrumentation set-up at this location. The remaining thermistor beads in this sector show that the foundation of this sector is not frozen.

Central Shallows (Sta. 30+645.5 to 30+804)

The majority of the piezometers installed in this area are frozen and give erratic data. Seepage station no. 7, which was active during the summer of 2016, is near this area.

The unfrozen piezometer indicates an increasing trend in pwp of approximately 1.5 m from 2013 to 2015. The increase in pwp occurs from January to May. In 2016, the recorded pwp was stable.

Central Channel (Sta. 31+020 to 31+220)

There is a seepage zone with ponding water observed downstream associated with this channel. The majority of the piezometers in this area are not frozen.

From 2012 to 2016, the maximum and minimum recorded pwp for the piezometers downstream has been constant. There is generally a pressure build-up from January to June followed by several pressure drops and increases from June to September. A minimum value around 131 m is recorded during freshet and a maximum value around 133.6 m is recorded during winter. The pwp data tends to fluctuate more during freshet than during winter. This



behaviour seems to be consistent with the explanation that the recorded pwp are influenced by the pumping of the water pond located downstream.

Channel 3 (Sta. 31+565 to 31+700)

There is a seepage zone monitored by station no. 6 associated with this channel. There is a drainage channel dug into the ring road in the area to allow water to flow freely in the pit. The piezometric array in this area are frozen and a cooling can be observed in the recorded temperature since 2011.

A sharp increase in pwp was recorded for most piezometers during the winter of 2014 (except one piezometer on the upstream side that is stable). This increase was approximately 1 m higher than the increase recorded during the winter of 2013. From 2014 to 2016, the pwp was stable in the piezometer located directly downstream (general decrease of 0.2-0.6 m while following seasonal trends). The piezometers located farther downstream have recorded a decrease of approximately 1.6 m since 2014 (while following seasonal trends).

Channels 1 and 2 (Sta. 31+815 to 32+105)

No seepage has been observed at the toe of the dike in 2016, but there is a water pond in this location naturally draining to Goose Pit. The majority of the piezometers are not frozen in this area.

A drop in recorded pwp (2 to 4 m) has been observed in the piezometers located in Channels 1 and 2 in the freshet of 2013. After this event, the recorded pwp has generally been stable (0.2 to 0.6 m fluctuation from winter to freshet) from 2013 to 2016 for the piezometric arrays of Channels 1 and 2.

The thermal data at Sta. 31+815 might indicate some sign of seepage as the thermal cooling is less pronounced and there is a wider fluctuation of temperature recorded at this location than in the other thermistor nearby.

4.3.2 Thermistor

Thirty-three thermistors (from T1 to T30 and T3' to T5') have been installed on Bay-Goose Dike. From September 2015 to September 2016, the following observations have been made.

Sta. 30+134 (T1), Sta. 30+827 (T14) and 32+140 (T30)

The three thermistors installed at Sta. 30+134 (T1), Sta. 30+827 (T14), and Sta. 32+140 (T30) are located on the northern abutment, Goose Island, and the western abutments. The first node of these thermistors is installed about 1 m below the dike crest. For this period, the dike and its foundation were entirely frozen on the northern abutment (T1), Goose Island abutment (T14), and the western abutment (T30).

Sta. 30+185 (T2), Sta. 30+489.5 (T9), Sta. 30+553.25 (T10), Sta. 30+621.5 (T11), Sta. 30+650 (T12), Sta. 30+713 (T13), Sta. 31+080 (T15), Sta. 31+134.5 (T16), Sta. 31+170 (T17), Sta. 31+352 (T18), Sta. 31+752.5 (T21), Sta. 31+820 (T22)

Twelve thermistors were installed in the SB portion of the cut-off wall. All the thermistors with the exception of T15 and T18 show a similar trend. The rockfill is frozen all year below El. 134 m. There is generally an active layer in the till and the rockfill is thawed all year. The till foundation did not remain frozen for the entire year for any thermistor and the bedrock was always in an unfrozen state with temperatures ranging from 2°C to 1°C.

The only exception to the general trends outlined above was T15 and T18. At T15 (31+080), the till foundation and 6 m of bedrock remained frozen all year. At T18 (31+352), the ground, including the entirety of the till foundation and the bedrock, remained frozen.



Sta. 30+260 (T3), Sta. 30+261.5 (T3'), Sta. 30+272 (T4), Sta. 30+273.5 (T4'), Sta. 30+288.5 (T5), Sta. 30+290 (T5'), Sta. 30+330.5 (T6)

This portion of the dike contains a cut-off wall where settlement could occur due to CSB, a rigid material, sitting on top of SB, a soft material. The designed thermistor nodes configuration for T3 (Sta. 30+260), T4 (Sta. 30+272), and T5 (Sta. 30+288.5) were modified to have nodes located very close together and were to be installed to monitor the interface between the CSB and SB materials as noted below. Thermistors T3, T4, and T5 were not installed to the designed depths, but instead have been installed below the interface and monitor the bedrock contact. These thermistors are recording temperatures above 0°C.

Thermistor T6 indicates that the ground is completely unfrozen below an elevation of 130 m. Therefore the till foundation was unfrozen from September 2015 to September 2016. From 130-133 m, the ground fluctuates above and below 0°C and from 133-135 m, and the dike remained frozen.

In 2011, AEM installed three more thermistors at Sta. 30+261.5 (T3'), Sta. 30+273.5 (T4'), and Sta. 30+290 (T5') that provide readings across the CSB/SB interface. The spacing between each node does not meet the design. No seepage directly downstream of this portion of the dike was observed; however, based on the topography, it is anticipated that seepage from this area could report to a lower point within the North Channel (i.e. 30+360). These thermistors show that the till and bedrock were completely unfrozen from September 2015 to September 2016.

Sta. 30+386 (T7), Sta. 30+417.5 (T8), Sta. 31+595 (T19), Sta. 31+605 (T20), Sta. 31+850 (T23), Sta. 31+880 (T24), Sta. 31+960 (T25), Sta. 31+995+ (T26), Sta. 32+030 (T27), Sta. 32+060 (T28), Sta. 32+100 (T29)

Eleven thermistors were installed in areas where the bottom of the cut-off wall was jet grouted. These thermistors show that the maximum active layer depth was above 135 m between September 2015 and September 2016. The majority of the rockfill stayed frozen all year and the till and bedrock were unfrozen all year with an exception at T29.

At T29, a part of the till foundation outside of the jet grouted area remained frozen for the entire September 2015 to September 2016 period. The jet grouted area, however, did not remain frozen at T29. The temperature of the jet grouted area varied between 3°C and 0°C.

4.3.3 Inclinerometers

Six inclinometers are installed at Bay-Goose Dike: Sta. 30+282, Sta. 30+390, Sta. 31+590, Sta. 31+815, Sta. 31+885, and Sta. 32+065. The inclinometer displacements are referenced along Axis A and Axis B; Axis A is perpendicular to the cut-off wall alignment (positive displacement towards the Pit side) while Axis B is perpendicular to Axis A, parallel to the cut-off wall (positive displacements towards the increasing chainage). The cumulative displacement in Axis A varied from 0.1 mm to 27 mm. Cumulative displacement values for Axis B varied from 0.1 mm to 20 mm. The larger settlement happened in the upper portion of the dike and in the thermal cap. Recorded displacements are mainly small and are within the tolerable displacements for the structure.

4.3.4 Seismograph

For every blast at Goose-Pit, seismograph monitoring of blast vibrations on the crest of Bay-Goose Dike has occurred. AEM analyse the monitored blast vibrations after each event. The maximum allowable PVS for all dikes is set at 50 mm/s per the designer recommendation. The highest recorded PVS for Bay-Goose from September 2015 to September 2016 was 38.8 mm/s at station DL1 near pit E4. No estimated tensile and shear strains were



calculated during the annual geotechnical inspection. The recorded PVSs were compared to the PPV values used in the previous Meadowbank Pit Blasting Effect Study, which considered the tensile and shear strains, indicating that the blast vibrations recorded are not a concern for the integrity of the dike.

4.3.5 Flow Meters

The flow was estimated from 4 seepage monitoring stations located at the downstream toe of the dike using a water collection pipe and a plastic bucket. From July to September 2016, the total average flow at the toe of the dike was measured at 24 m³/day compared to 29 m³/day in 2015, 132.2 m³/day in 2013, and 97.2 m³/day in 2012. The measured flow in 2016 and 2015 does not take into account the inflow of water from the pond at Central Channel as this value was not measured in 2016 and 2015 (61 m³/day in 2013 and 2014).

It is recommended to continue monitoring the evolution of the seepage at the toe and continue measuring the inflow of water from the pond at Central Channel.

4.4 Vault Dike

Five thermistor strings were installed on Vault Dike following its construction in the winter of 2013. T3 is installed in the deepest channel downstream, T5 is installed under the liner, T6 is installed upstream of the liner, T7 is installed east of the deepest channel, and T8 is installed upstream in the deepest channel outside of the key trench. The Vault Dike thermistor data are presented in Appendix C1. The instrumentation is indicating that the structure is behaving as expected with data following historical trends.

The following thermal regime observation were made :

- All beads of thermistor TH-3 stopped working in October 2015;
- The instrumentation shows that the entire foundation of Vault Dike (till and bedrock) is frozen;
- The active layer in the rockfill was up to 2 m thick in the summer of 2016.

4.5 TSF South Cell

4.5.1 Central Dike

Instruments were installed on Central Dike to monitor the dike's performance during its construction, operation, and closure. Nine boreholes were drilled on three rows corresponding to the central key trench (545-P1, 580-P1, 650-P1 and 750-P1), the final downstream toe (545-P2 and 650-P2) and the Portage Pit limit (465-P3, 650-P3, 875-P3 and WR-P3). Piezometers and thermistor strings were installed in each of these boreholes (for a total of 32 piezometers and 9 thermistors).

Four additional boreholes were drilled and instrumented in 2016 during the seepage field investigation in the key trench alignment (595-P1, 810-P1, 825-P1 and 850-P1). Piezometers and thermistor strings were installed in each of these additional boreholes (for a total of 15 piezometers and 4 thermistors). Two thermistor strings are also installed on the upstream face to monitor the temperature within the tailings of the South Cell.

The following presents a summary of the data collected until September 2016 for the piezometers and the thermistors. Data plots for the instrumentation sent by AEM are presented in Appendix C2.



4.5.1.1 Thermistors

The thermistors installed in 2013 are showing similar trends as in the past. The instruments installed in 2016 are showing similar trends as the instruments installed in 2013 in similar areas.

The following observations of the thermistor data can be made:

- The instruments installed along the central key trench (545-P1, 580-P1, 595-P1, 650-P1, 750-P1) show thawed conditions (between 1°C and 2.5°C) within the till, the bedrock and the rockfill (from El. 110 m to 65 m).
- The instruments installed along the downstream toe of the Central Dike footprint for a final crest elevation of 150 m indicate that the till units at 545-P2 and 650-P2 stayed frozen in 2016 while the majority of the bedrock foundation did not freeze (between 0.1°C and 1.5°C degree below El. 97 m).
- Throughout the year, temperature variations of less than 1°C can be observed for each bead. The bedrock temperature from El. 105 to 55 m varies from -6°C to -3.5°C at 465-P3, from -7.5°C to -1°C at 650-P3 and from 0°C to 1.5°C at 875-P3. This seems to indicate that a permafrost condition is developed in part of the Portage Pit Wall while the part aligned with the south abutment of Central Dike did not freeze during the year.
- The thermistor installed in the West Road (745-TH3) indicated that the rockfill stayed in frozen conditions below El. 120 m and that the dense till stayed frozen all year.

These observations tend to confirm the visual observation of seepage downstream as the foundation of the dike (till and bedrock) on the downstream side are unfrozen all year. Till and bedrock temperature tend to decrease further from the downstream side and the piezometer near Portage Pit show permafrost condition.

4.5.1.2 Piezometers

It can be observed that the piezometers located in boreholes between Sta. 595 and Sta. 875 are strongly reacting to the level of the water pond located downstream of Central Dike. In those boreholes, the 23 piezometers that are non-frozen and that are not in suction are recording piezometric elevation around El. 115 m and have strongly reacted to the pumping of the downstream pond in 2015. The piezometers between Sta. 595 and Sta. 875 located in the rockfill, till and bedrock are reacting similarly, which seems to indicate an hydraulic connection between the downstream pond, the till and the bedrock. The piezometric elevation recorded in the till and the bedrock between Sta. 595 and Sta. 875 is generally slightly higher than the elevation of the downstream pond, indicating excess pore water pressure. Piezometer 875-P3A is very interesting, as it is the only one that seems to react to the South Cell level instead of the downstream pond level.

With the exception of 545-P1-D, the piezometers located between Sta. 465 and Sta. 580 are not reacting to the downstream pond water level or the elevation of the South Cell, and indicate much lower piezometric elevations. The exception to this observation is piezometer 545-P1-D, located in the till, that recorded a drastic increase in piezometric elevation when deposition started in the South Cell in 2014. This piezometer recorded another significant increase in piezometric elevation in the summer of 2015, which at the time was higher than the South Cell water level. Since October 2015, the piezometric elevation in this piezometer has stabilized to El. 125 m.

Generally, a downward hydraulic gradient in part of the bedrock and of the till can be interpreted in piezometers located in the same boreholes. Small upward gradients in the till or the upper bedrock can also be observed in some boreholes, such as 650-P1 and 750-P1. Significant upward pressure gradients in the bedrock can be



observed in holes 825-P1, 850-P1, 875-P3. It is not possible to observe a generalized upward hydraulic gradient trend that would indicate that pressurised bedrock is transmitting pore water pressure to the till. The piezometric elevation in the bedrock is often similar or smaller than recorded in some parts of the till layer. However, due to the topography, it is possible that water is reporting from bedrock located higher and induces excess pore water pressure on the foundation soil located lower below.

Like previous years, it can be observed that some piezometers are recording negative pressure (suction). Negative pressure for unfrozen conditions was recorded in eleven piezometers. Piezometers in suction are recording very few variations in measured pore water while the other instruments are reacting to the downstream pond elevation. These instruments are generally located in the bedrock. Based on the available information, it is not possible to determine the exact cause of this suction. This could be due to a problem with the instruments or to a non-continuous geological environment in which the water table is locally below the installation depth of some of the instruments. Table 3 indicates the instruments measuring suction. The results of these instruments must be interpreted with caution.

By comparing the piezometers' installation elevation to the thermistor readings, it is possible to observe that six piezometers have experienced temperatures below 0°C in the past. Four of these piezometers also recorded suctions. The piezometers that were frozen generally showed piezometric readings that were stable except for 465-P3-A and 650-P3-B. A piezometer that has frozen once cannot be relied upon even if it thawed, as freezing generally breaks the piezometer or shifts its calibration curve. It is recommended to flag these piezometers and be careful when interpreting their data even if they seem to make sense. For example, 650-P3-A closely follows the water level fluctuations of the South Cell until 2015, but since it is frozen, the decrease in pore water pressure recorded might not be representative of actual field conditions. Table 3 indicates the instruments that could have frozen in the past.

Table 3: Observations on the Piezometer Readings of Central Dike

Name of Piezometer	Installation Unit	Observation
545-P1-A	Bedrock	Suction
545-P1-D	Till	Starting in September 2014, the piezometric elevation started to increase rapidly and equilibrate with the South Cell water level. Another rapid increase in 2015
580-P1-A	Bedrock	Sudden increase in summer 2016 – instrument stopped working in July 2016
580-P1-(B to D)	Bedrock and till	Instruments stopped working in July 2016
580-P1-E	Rockfill	Suction – instruments stopped working in July 2016
595 (A to E)	Till, bedrock, rockfill	Piezometric elevation similar to downstream pond. Casing stuck in the bedrock
650-P1-A	Bedrock	Suction
650-P1-B	Bedrock	Piezometric elevation fluctuates with downstream pond level
650-P1-(C,D)	Till	Piezometric elevation fluctuates with downstream pond level
750-P1-(A,B,C)	Bedrock	Recorded suction
750-P1-D	Till	Piezometric elevation fluctuates with downstream pond



Name of Piezometer	Installation Unit	Observation
750-P1-E	Rockfill	Piezometric elevation fluctuates with downstream pond
545-P2-B	Bedrock	Suction
545-P2-C	Bedrock	Frozen, suction
545-P2-D	Till	Frozen
650-P1 (B,D)	Bedrock and till	Broken since August 2016
650-P2-(A,B)	Bedrock	Piezometric elevation fluctuates with downstream pond level
650-P2-C	Bedrock	Piezometric elevation fluctuates with downstream pond level, frozen
650-P2-D	Till	Frozen
465-P3-A	Bedrock	Frozen
465-P3-B	Bedrock	Frozen
650-P3-A	Bedrock	Piezometric elevation fluctuates with downstream pond
650-P3-B	Bedrock	Frozen
875-P3-A	Bedrock	Piezometric elevation fluctuates with South Cell pond
875-P3-B	Bedrock	Piezometric elevation fluctuates with downstream pond

4.5.1.3 Seismograph

For every blast at Portage Pit, seismograph monitoring of blast vibrations on the crest of Central Dike has occurred at four locations along the dike. AEM looks at the monitored blast vibrations after each event. The maximum allowable PVS for all dikes is set at 50 mm/s per the designer recommendation. The highest recorded PVS for Central Dike from September 2015 to September 2016 was 15.50 mm/s.

4.5.1.4 Turbidity and Water Quality

The turbidity of the downstream water pond was monitored in 2015 and 2016. The turbidity of the downstream pond increased with the pump speed. It can also be observed that the turbidity decreased in the freshet. The turbidity levels are generally lower than 15 NTU and the water is clear in the downstream pond.

Chemical analyses were done during the year for water samples taken in the South Cell, a groundwater well on the downstream side, the downstream water pond, and a sump in North Portage pit. The concentration of iron and sulphate is similar between the South Cell, the downstream pond and the North Portage pit sump. Nitrate was found in the North Portage Pit and downstream pond. However, iron, sulphate and nitrate are generated during the mining activity, which explains their concentration in the North portage Pit Sump. Concentrations of chloride similar to the South Cell as well as small quantities of cyanide were found in the downstream pond. Cyanide is volatile and sometimes could not be measured in the South Cell sample, which explains its low quantity in the downstream pond.

4.5.2 Saddle Dam 3

Four thermistors are installed at Saddle Dam 3. Three of these thermistors are located along the axis of the faulted zone that was encountered during the construction of Saddle Dam 3 (around 20+650). Along this axis, one thermistor is installed downstream, one is installed on the crest, and the other is installed on the upstream toe liner tie-in. Another thermistor is installed at 20+720 within the upstream toe liner tie-in. These thermistors are mostly



in permafrost condition. It will be important to follow the performance of the structure once Saddle Dam 3 become operational for containment of tailing and supernatant water.

4.5.3 Saddle Dam 4

Two thermistors are installed at Saddle Dam 4 near Sta. 40+300. One thermistor is installed on the crest while the other is installed on the upstream toe liner tie-in. These thermistors are mostly in permafrost condition. It will be important to follow the performance of the structure once Saddle Dam 4 becomes operational and is used to retain tailings and water.

4.6 TSF North Cell

4.6.1 Saddle Dam 1

Thermistor data from within the structure indicate that the dike foundation remained frozen from September 2015 to September 2016. The foundation soil and bedrock remained in a frozen state with temperatures ranging from about -2°C to -5°C. At the upstream toe, below El. 132 m, the compacted till base material below the liner remained frozen. The majority of the rockfill shell remained frozen during the reported year as the active layer was 2 m. The instrumentation indicates that the structure is behaving as expected with data following historical trends.

No sign of seepage or thawing of the foundation soil can be observed from the instrumentation data. The structure is performing as expected.

Plots of the Saddle Dam 1 thermistor data are presented in Appendix C3.

The SD1-T1 thermistor string is installed in the centre of the upstream face of the dike immediately beneath the geomembrane liner to monitor temperatures within the deposited tailings. A thin layer of protective granular material exists above the geomembrane liner at this location. This thermistor indicates that the tailings are frozen below El. 147.5 m approximately with temperatures ranging from -1°C to 0°C, and that there is an active zone in the tailings above El. 147.5 m.

The SD1-T2 thermistor string is installed vertically through the upstream Stage 1 crest in the centre of the dike at El. 140 m. The data show that the dike foundation remained frozen during the past year with temperatures fluctuating between -1.5°C and -4.5°C, which is consistent with historical data. Temperatures between 0°C and -1.5°C were recorded in the rockfill of the dike, which remained frozen all year long below El. 140 m. No active layer has been observed below El. 140 m since 2015.

The SD1-T3 thermistor string is installed vertically through the upstream Stage 2 crest in the centre of the dike at El. 150 m. It can be observed that the dike foundation and dike rockfill remained frozen during the past year with temperatures around -5°C. An active layer in the rockfill can be observed above El. 146 m. The remaining of the rockfill stayed in frozen conditions. The trends observed are consistent with the data from the past years.

The SD1-T4 thermistor string is installed vertically through the upstream toe of the dike near the centre of the dike. It indicates that the dike foundation on the upstream toe, including the liner tie-in till plug, remained totally frozen since 2011.

4.6.2 Saddle Dam 2

Thermistor data from within the structure indicates that the dike foundation remained frozen from September 2015 to September 2016 with temperatures ranging from -5.5°C to -7°C. At the upstream toe of the dike, the semi-pervious backfill remained frozen during the year. The rockfill mostly stayed in frozen condition with an active layer



above El. 148 m. The instrumentation indicates that the structure is behaving as expected with data following historical trends.

No signs of seepage or thawing of the foundation soil were observed. The structure is performing as expected.

Plots of the Saddle Dam 2 thermistors data are presented in Appendix C3.

The SD2-T1 thermistor string is installed in the centre of the upstream face of the dike immediately on top of the geomembrane liner to monitor the thermal regime of the tailings in contact with the structure. This thermistor indicates that the tailings are frozen all year below El. 147.5 m approximately (temperature between 0°C and -5°C) and that there is an active layer above that elevation.

The SD2-T2 thermistor string is installed vertically through the upstream crest in the centre of the dike at El. 140 m. It shows that the dike foundation remained frozen for the past year (temperature varying from -2°C to -7°C).

The SD2-T3 thermistor string is installed vertically through the upstream liner tie-in trench near the centre of the dike at about El. 144 m. It shows that the dike foundation and the semi-pervious backfill placed on top of the compacted till remained frozen during the past year (temperature of the foundation between -6°C and -7°C).

The SD2-T4 thermistor string is installed vertically through the upstream toe about mid-way between the centre of the dike and the northwestern abutment. It shows that the dike foundation remained frozen during the past year along with the compacted till base material below the geomembrane liner in this area. The semi-pervious backfill placed on top of the compacted till also remained frozen during the summer of 2016. The temperature varied between -5°C and -6°C.

4.6.3 RF1-RF2

Four thermistors were installed in 2012 to monitor the temperature of RF1 and RF2 (which delineates the northeastern side of the TSF's North Cell). Plots of these thermistors' data are presented in Appendix C3.

Three thermistors are installed on RF1 (T121-1, T73-6, and RF1-3). Thermistor T121-1 shows frozen conditions all year long with temperatures varying from -0.8°C to -5.5°C. Thermistor T73-6 shows temperatures between 0.5°C and -0.5°C below El. 145 m and the presence of an active layer above that elevation. RF1-3 shows frozen conditions all year long below El. 147 m with temperatures varying between 0°C and -4°C. Above that elevation, there is the presence of an active layer within the upper elevation of the deposited tailings.

One thermistor is installed on RF2 (T122-1) and shows temperatures that vary from -2°C to -6.5°C, indicating that the RF2 foundation is in a permafrost state.

4.6.4 North Cell Tailings

Five thermistors are installed in the tailings of the North Cell of the TSF (SWD-1, SD2-1, 90-1, NC-TH-1 and NC-TH-2). These thermistors were installed from 2012 to 2016. Plots of these thermistors' data are presented in Appendix C3. They indicate that the tailings in the North Cell are not entirely frozen, including in the talik area where the reclaim pond was kept during operation.

Thermistors SD2-1 and SWD-1 were installed in April 2014 in the tailings of the North Cell near SD2 and SWD. Data for these instrument were available only from April 2014 to October 2014.

Thermistor 90-1 was installed in 2012 in the tailings of the North Cell near Saddle Dam 1. In 2016, the tailings at that location from El. 143 m to El. 130 m were frozen all year.



Thermistor NC-T1 and NC-T2 were installed in April 2016 in the tailings of the North Cell in the location of the former reclaim pond. NC-T1 show tailings temperature between 0°C and 4.5°C below El. 144 m and frozen tailings above that elevation. NC-T2 show tailings temperature between 0°C and 2°C below El. 134 m and frozen tailings above that elevation.

4.7 Stormwater Dike

On August 25, 2016, 2 extensometers, 4 crack monitoring stations and 3 prisms were installed on the crest of SWD in the area showing movements (between Sta. 10+500 and 10+750 approximately). From August 2016 to October 3, 2016, the extensometers and the prisms measured global movement between 90 mm and 110 mm. The movement measured by the prisms had a lateral and vertical component. It can be observed that the movement measured by the extensometers and the prisms started to stabilize around September 15 and mainly stopped around September 21. The stabilization of the movement is attributed to the construction of the rockfill buttress downstream. The crack monitoring stations measured crack openings varying from 2 to 12 mm. The width of the cracks increased until the first week of installation of the instruments, then stabilized.

A single deep thermistor (T147-1) and piezometer string (VWP 13265) were installed at the downstream toe of Stormwater Dike (within the South Cell). These instruments were broken in September 2016 during the construction of the buttress at the toe of Stormwater Dike within the South Cell. It is important to note that the ground surface at the location of this thermistor was around El. 125 m with the first thermal node at El. 120 m. It was not possible to obtain information about the lakebed sediment layer from this instrument. Thermistor T147-1 showed the existence of a frozen crust of material from El. 120 m to El. 112 m. Below El. 112 m, the temperature varied between -0.3°C and 0.1°C. Piezometer VWP 13265 was responding to the water level of the South Cell before it was broken.

Per the MDRB recommendations, AEM will install additional instruments to monitor the response of Stormwater Dike during tailings deposition in the South Cell. It is planned to install additional piezometers, thermistors and prisms.

Plots of Stormwater Dike thermistor and piezometer data before they broke are presented in Appendix C3. The movement monitoring data can also be found at the end of this appendix.

5.0 ALL-WEATHER PRIVATE ROAD

The All-Weather Private Road (AWPR), formerly referred to as the All-Weather Private Access Road (AWPAR), was built in 2007-2008 to connect the hamlet of Baker Lake to the Meadowbank Mine site (Figures 2A, 2B, and 2C). The road is approximately 107 km long with nine bridge crossings and culverts installed at a total of thirty-eight locations. Table 4 at the end of Section 5.2 lists each structure along the AWPR, their designated name, their approximate location and the observations noted during the inspection.

The road design is based on a general rockfill sub-base and crushed granular rockfill surfacing with a combined minimum thickness of 1 m over thawed stable soil and 1.2 m over thawed susceptible soil.

No sign of thermal degradation of the permafrost was observed on the road during the inspection. It should be noted that sign of thermal degradation may not necessarily be observed due to the regular road maintenance performed by AEM. During the inspection, water levels and flow velocities at the crossings were normal for the time of year.



Fill material that comprises the majority of the road provides no significant barrier to low gradient water flow due to its coarse nature. During higher flow and runoff periods, water may flow through portions of the road fill. Water was not observed flowing through the rockfill near the culverts during the inspection, but signs that water flowed beneath the road were observed at some locations during the inspection. This could also be due to the inlet or the outlet of some culverts having been installed too high or too low, which did not promote the flow of water through the culvert until a certain water level had been reached.

During the year, AEM conducts regular and event-based visual inspections of the fish-bearing water crossing locations along the access road. This data should continue to be compiled by AEM to confirm the hydraulic function of the crossings, the adequacy of the crossing locations with respect to the watercourses, and minimal impact to fish habitat.

It is understood that AEM's monitoring program includes an assessment of sedimentation and potential erosion issues at the major bridge crossings. Consideration should be given to expanding AEM's monitoring program to include all culverts and bridges along the road to assess whether they are providing adequate capacity during the freshet and following large precipitation events.

5.1 Culverts

The culverts were generally in good condition at the time of the inspection. No significant degradation of culvert conditions has been observed when compared to the 2015 inspection. Most culverts were unobstructed with no signs of erosion and no signs of damage to the culverts.

A photographic log of the inspected culverts is provided in Appendix D1. Culverts in the following discussion, and in the photographic log, have been identified by name (e.g. R-24) to be consistent with those indicated on the as-built drawings provided by AEM and as shown on Figures 2A to 2C. Some of the additional culverts installed in 2010 and 2011 are not shown on these figures. Each culvert is also identified by its approximate kilometre location (e.g., km 98+250) along the road alignment.

Signs indicating that minor erosion has occurred were observed at the inlet of PC-17A (8+830), and the outlet of R14 (km 67+840) and R24 (km 98+100). No action is recommended for the culverts showing sign of erosion as the situation seems stable. Culvert erosion progression should be monitored at freshet.

During the inspection, signs of water flowing beneath the road were observed at some locations. This is generally due to the inlet or the outlet of the culvert having been installed too high or too low, which did not promote the flow of water through the culvert until a certain water level had been reached. This condition can promote erosion and risk of washout beneath the road and should be monitored. This situation has been observed in the past and seem to be stable as no signs of deteriorating conditions were observed. This condition was observed at PC-17A (8+830), R-18B (80+950), R-20 (85+490), and R-23 (93+600). The progression of the situation should be monitored at freshet.

Obstructed and damaged culverts were observed at some locations during the inspection. In many cases, the obstructions are related to inlets and/or outlets becoming partially or completely obstructed by accumulated rockfill and road material. There was no substantial increase in the number of significantly damaged culverts observed during the 2016 inspection when compared to last year. The following culverts were too damaged and obstructed to function properly: R-00A (2+550), culvert at 5+700, PC-14 (4+260) and PC-16 (54+950). If insufficient capacity to handle the flow is observed at locations where culverts are obstructed or damaged, it is recommended to clear the obstructions or repair the culvert.



Table 4, found at the end of Section 5.2, describes the observations for each culvert at the time of the inspection as well as recommendations. For example, for some culverts it is recommended to monitor the water level upstream and the flow through the culverts during high flow events (e.g. freshet season).

5.2 Bridges

Nine bridges are located along the AWPR: four Acrow Panel bridges and five Rapid Span bridges. A structural and/or mechanical assessment of the bridges was not conducted and is beyond the scope of this geotechnical inspection. A description of the observations of the bridges made during the inspection is presented in Table 4. A photographic log of the bridges is included in Appendix D2.

The bridges have been identified in sequence, increasing in number along the road from Baker Lake to Meadowbank (e.g. from Bridge 1 to Bridge 9). The name of each bridge (e.g. R02) is consistent with the as-built drawings of the AWPR provided by AEM. Each bridge is also identified by its approximate kilometre location (e.g. km 8+750).

Due to the low-lying terrain between Baker Lake and Meadowbank, water flow typically occurs in broad areas and not in well-defined channels. The majority of water crossings spanned by bridges have increased channelization of flow due to the embankment fill at the crossing location. No significant signs of embankment erosion were observed at the time of the inspection as they are generally constructed with coarse rockfill.

The bridges and their embankments were in good geotechnical condition at the time of the inspection. Signs of settlement were observed at Bridge R-15 and this condition should continue to be monitored. The following observations were made for each bridge during the inspection:

- **Bridge 1, R02 at about km 8+750:** Normal flow was observed at the time of the inspection. No signs of erosion or turbidity were noted. In 2011, two additional culverts of 1,800 mm in diameter were installed nearby to increase the drainage capacity during high flow events and prevent the road and the bridge from washing out. It is understood that AEM removes snow and ice at this location and other bridges before the freshet and will continue this practice in the future.
- **Bridge 2, R05 at about km 17+600:** Minor damage to the bin wall of both abutments was observed, and is likely a result of past snow removal activities. No evidence of erosion was observed and the foundation was in good condition. The streambed consists primarily of cobbles, gravel and a few boulders towards the perimeter of the channel.
- **Bridge 3, R06 at about km 23+100:** Construction of the bridge has concentrated flow in this area. No signs of erosion or turbidity were observed and the bridge was in good condition at the time of the inspection.
- **Bridge 4, R09 at approximately km 48+500:** Construction of the bridge has concentrated flow in this area. No signs of turbidity or erosion were observed at the time of the inspection and the bridge was in good condition.
- **Bridge 5, R13 at about km 62+060:** At the time of the inspection, the bridge was in good condition. No signs of turbidity or erosion were observed.
- **Bridge 6, R15 at about km 69+200:** Signs of settlement were observed as the bridge was dipping toward the western side on both abutments. The bridge foundation did not show any signs of adverse conditions. No remediation work is recommended for the moment, but the situation should be monitored. Minor damage



to the bin wall of both abutments was also observed, and is likely a result of past snow removal activities. No evidence of erosion or turbidity was observed.

- **Bridge 7, R16 at about km 73+800:** No signs of erosion or turbidity noted. Construction of the bridge has concentrated the flow in this area.
- **Bridge 8, R18 at about km 79+500:** The bridge was in good condition. A boulder field is located beneath the bridge and no flow was observed at the time of the inspection.
- **Bridge 9, R19 at about km 83+150:** Steel plates with pipe anchors are installed along both embankments of the bridge. Some damage (bending) to the steel containment plates was observed, which may be associated with snow removal activities. The damage is minor and does not impact the geotechnical integrity of the bridge or of the embankment as the surrounding pipes seem to hold the metal sheet in place (protecting the abutment backfill). No turbidity or erosion was observed at the time of the inspection.



**2016 ANNUAL GEOTECHNICAL INSPECTION
MEADOWBANK GOLD MINE, NUNAVUT**

Table 4: Inspection of the Facilities along the All-Weather Private Road

Station	Name	Structure Description	Comments
0+430	PRC1	1x600 mm CSP	Culvert owned by the town and not AEM. Minor damage to outlet. Minor obstruction of the outlet. Still in good condition. No action required
0+470	PRC2	2x600 mm CSP	Culvert owned by the town and not AEM. Good condition
1+380	PRC3	1x600 mm CSP	Culvert owned by the town and not AEM. Good condition
2+550	R-00A	1x600 mm CSP	No sign of any flow. Inlet partially collapsed, outlet entirely collapsed with signs of obstruction from road material, one hole in the culvert visible from the crest of the road. AEM should monitor if the culvert receives some flow during the freshet season. If no flow, then recommend removing the culvert. If monitoring indicates a culvert is necessary at this location, then it is recommended that AEM replace the culvert and provide adequate backfill around the culvert to protect it.
4+260	PC-14	2x600 mm CSP	These culverts are too damaged to function any longer. If needed, new culverts should be installed further north.
5+200	Quarry 1		Slope remediation in progress. Rock walls are generally clean and stable.
~5+700	unnamed	1x600 mm CSP	The outlet is partially buried in gravel.
8+750	R02 Centre Bridge	30 m Acrow Panel Bridge	In good condition
8+830	PC-17A	2x1800 mm CSP	Sign of erosion beneath the inlet and flow of water occurring beneath the culvert. The 1800 CSP were installed too high. While conditions are not perfect, they have proven stable over the past years.
8+850	PC-17	2x1200 mm CSP	In good condition
9+952	PC-1	1x600 mm CSP	In good condition
10+580	R-03	1x600 mm CSP	In good condition
12+050	R-04	1x1200 mm CSP	In good condition
12+745	PC-13	1x600 mm CSP	In good condition



**2016 ANNUAL GEOTECHNICAL INSPECTION
MEADOWBANK GOLD MINE, NUNAVUT**

Station	Name	Structure Description	Comments
13+250	Quarry 2		Slope remediation in progress.
13+405	PC-2	1x600 mm CSP	In good condition.
13+685	PC-3	1x600 mm CSP	In good condition.
13+950	unnamed	1x600 mm CSP	In good condition.
14+910	PC-4	1x600 mm CSP	In good condition.
15+745	R-05A	1x1200 mm CSP	In good condition.
17+600	R05 Center Bridge	30 m Acrow Panel Bridge	In good condition. Minor damage to the bin wall of both abutments as a result of past snow removal activities.
18+280	PC-5	1x600 mm CSP	In good condition.
18+900	PC-6	1x600 mm CSP	In good condition.
20+240	PC-7A	2x600 mm CSP	The inlet of the southern culvert is partially obstructed by gravel and the outlet of the northern culvert is damaged.
20+250	PC-7	1x600 mm CSP	In good condition.
23+100	R06 Center Bridge	30 m Acrow Panel Bridge	In good condition.
23+700	Quarry 3		A crusher is installed in this quarry. The west wall is in good and stable condition, but would need additional cleaning. AEM did not clean it due to the presence of a falcon nest.
25+900	R-07	1x1200 mm CSP	In good condition.
29+420	PC-8	1x600 mm CSP	In good condition.
31+300	Quarry 4		Quarry flooded. In good condition.
34+650	Quarry 5		Slope remediation in progress. Rock walls are in good and stable condition, except for a small portion on the east side.
35+690	PC-9	1x600 mm CSP	In good condition.



**2016 ANNUAL GEOTECHNICAL INSPECTION
MEADOWBANK GOLD MINE, NUNAVUT**

Station	Name	Structure Description	Comments
36+470	Quarry 6		Slope remediation in progress. The remaining rock walls are clean and stable.
36+865	PC-10	1x600 mm CSP	In good condition.
39+552	PC-11	1x600 mm CSP	In good condition, but almost submerged by water.
39+800	Quarry 7		The quarry walls are in unstable condition.
41+300	PC-12	1x600 mm CSP	In good condition, almost submerged.
42+950	Quarry 8		Slope remediation in progress.
44+600	Quarry 9		Presence of unstable loose rocks and boulders. Slope remediation in progress.
48+500	R09 Center Bridge	12 m Rapid Span Bridge	In good condition.
48+900	Quarry 10		Slope remediation in progress. The steep west rock wall is unstable. There is an oil spill at the entrance of the quarry.
53+500	Quarry 11		Slope remediation in progress. Rock walls are clean and stable, except for the eastern portion.
54+950	PC-16	1x600 mm CSP	Not observed in 2016. Probably buried. To be cleaned if water is ponding at freshet in this location.
58+300	Quarry 12		Slope remediation in progress. Rock walls are friable, loose and unstable.
62+060	R13 Center Bridge	12 m Rapid Span Bridge	In good condition.
62+350	Quarry 13		Slope remediation is in progress. Loose blocks were observed in some portions of the rock wall.
65+700	Quarry 14		Quarry flooded, slope remediation in progress. Loose blocks were observed in some portions of the rock wall.
67+600	Quarry 15		Slope remediation in progress. Steep rock wall in stable condition.
67+840	R-14	3x1200 mm CSP	Middle and northern culverts show small signs of erosion at the outlet and have been damaged (collapsed) inside, below the road, but it is anticipated that they will continue to perform well. All of them were installed too high but function well. No action required.



**2016 ANNUAL GEOTECHNICAL INSPECTION
MEADOWBANK GOLD MINE, NUNAVUT**

Station	Name	Structure Description	Comments
69+200	R15 Centre Bridge	30 m Acrow Panel Bridge	Bin wall of both abutments were observed to be damaged but they are holding well. The bridge is dipping toward the west side on both north and south abutments. The foundation does not show any signs of failure but is slowly settling. Its condition should be monitored.
70+400	Quarry 16		Slope remediation in progress. Presence of unstable loose rocks and boulders.
72+800	Quarry 17		Slope remediation in progress. Steep rock wall in stable conditions.
73+800	R16 Centre Bridge	12 m Rapid Span Bridge	In good condition.
77+440	R-17	1x1200 mm CSP	In good condition.
79+500	R18 Centre Bridge	12 m Rapid Span Bridge	In good condition.
80+200	Quarry 18		Slope remediation in progress. Steep walls are in good condition.
80+950	R-18A	3x1200 mm CSP	In good condition. The southern culvert inlet is partially buried.
	R-18B	1X600 mm CSP	In good condition, installed above ground surface (water can flow under culvert).
83-150	R19 Centre	12 m Rapid Span Bridge	Some damage to the steel containment plates and to one pile was observed, which may be associated with snow removal activity. The damage is minor and does not affect the geotechnical integrity of the bridge.
84+300	Quarry 19		Slope remediation has begun. Remaining walls are in good condition.
85+490	R-20	1x1200 mm CSP	Outlet of the culvert is slightly twisted. The middle of the culvert is slightly collapsed. The inlet is installed above the ground surface and water is able to flow beneath the culvert. No follow-up required, in stable conditions.
87+300	R-21	2x1200 mm CSP	Both culverts are slightly collapsed in the middle. Should have been installed lower to avoid erosion issue. In stable condition.
89+550	Quarry 20		Slope remediation in progress. Quarry walls are in good condition.



Station	Name	Structure Description	Comments
93+400	Quarry 21		Slope remediation in progress. Quarry walls are in good condition.
93+600	R-23	1x1200 mm CSP	Minor damage near the top, but still in good condition. The culvert is installed too high and as a result there is a low flow of water through the road rockfill. The situation has been under control over the past years.
98+100	R-24	2x1200 mm CSP	Both outlets are installed too high. The outlet of the southern culvert still shows small signs of erosion, but this has been under control over the past years. Both culverts show deformation in the upper part.
99+200	Quarry 22		Slope remediation in progress.
101+950	R-25	2x600 mm CSP	One culvert is angling up toward the downstream end and natural drainage by gravity does not occur. A second culvert alongside is well installed and should drain water for the remainder of the season. No sign of erosion observed during the inspection.
104+400	R-26	3x1200 mm CSP	Small obstruction in the west inlet by a boulder (0.4 m). The culvert is in good condition, no follow-up required.
	Quarry 23		Presence of loose rocks on top of steep wall.

6.0 QUARRIES

Twenty-two quarries were developed in the past along the AWPR to provide material for its construction. An additional quarry was developed near the airstrip at Meadowbank to provide further construction materials. All quarries were inspected as part of the geotechnical inspection and a photographic log is presented in Appendix E. Table 4 above presents a summary of the observations and recommendations made during the 2016 inspection for the structures along the AWPR road including the quarries. In accordance with the as-built drawings, the quarries have been numbered sequentially from 1 to 22 starting near Baker Lake and increasing towards Meadowbank. The airstrip quarry is referred to as Quarry 23 and is used to store miscellaneous items such as drill core on racks, diamond drill contractor drill rigs, sea-can containers, pipes, and culverts.

The closure and reclamation plan requires that all quarries and borrow sources developed during the construction of the AWPR be reclaimed following their use. The closure plan further requires that all quarry slopes be left at an angle of 45 to 50 degrees. During the inspection, it was observed that slope remediation was in progress but none of them were totally reclaimed. It has been observed that most quarries had been cleaned since the 2015 inspection. Loose blocks and granular material were also removed from most quarry walls. Loose blocks and granular material had been placed at the toe of the walls. At the time of the inspection, the majority of the quarries were dry.



During the inspection, it was observed that Quarries 4 and 14 were flooded. These quarries have been flooded for a couple of years and it is understood that AEM is evaluating how to eliminate the ponding of water within these quarries. Quarries 5, 13 and 15 contained minor accumulations of water. Quarries that contain significant amount of ponded water should be monitored to assess if ponding persists and, if necessary, whether ditches should be developed to facilitate the drainage of water.

Unstable blocks and loose rocks along steep walls remain in Quarries 3, 7, 9, 10, 12, 16 and 23. The west wall of Quarry 3 also contains a falcon nest that prevents its maintenance. It is recommended that workers be cautious in these quarries and are aware of the potential hazard.

7.0 BULK FUEL STORAGE FACILITIES

This section contains the observations made during the 2016 annual inspection of the Baker Lake and Meadowbank tank farm facilities (Main Camp and Vault).

7.1 Baker Lake Tank Farm

The Baker Lake tank farm consists of six large-capacity tanks (10 million litres each) and twenty Jet A fuel tanks (100,000 litres each) that have been constructed within four bermed areas (containment cells). Tanks 1 and 2 are located within the first containment area, which is located on the western side of the fuelling area. Tanks 3 and 4 are located within a second containment area adjacent to the first. A central berm is located between the two containment areas. Tanks 5 and 6 are within the third containment area located north and upslope of Tanks 3 and 4. Tanks 5 and 6 are situated within an entirely separate containment cell subexcavated into the hill slope above the initial tank farm area. Twenty Jet A Fuel tanks were installed in 2013 in a containment area located northwest of Tanks 5 and 6 lying over a 0.5 m-thick granular base fill material.

Each containment area has been lined with a 1.5-mm high density polyethylene (HDPE) geomembrane to provide secondary containment.

Visual inspection of the majority of the liner in the containment areas for Tanks 1 to 6 was not possible as it is covered with granular fill material to provide protection. The granular fill material protecting the geomembrane was eroded due to wave actions in some areas, exposing the geomembrane. This condition was observed all along the south side of Tanks 3 and 4 and on the west side of Tank 1. A hole in the exposed geomembrane (300 mm diameter hole) was observed on the south southwestern corner of Tank 3 at the toe of the slope. The hole in the geomembrane should be repaired to ensure a good performance of the retention basin. It is also recommended to cover the exposed area with geotextile and fill material to re-establish the liner protection.

Ponded water was observed on the southern side of the first, second and third containment areas. Presence of water on the southern side of the containment areas was reported in the 2011 to 2015 geotechnical inspections. No sump or pump was visible during the site visit. It is recommended to keep the water accumulation at a minimum near the tank foundation.

The geomembrane of the containment cell of the twenty Jet A fuel tanks remains uncovered around the tanks. Water was observed ponding within the eastern and southern side of that containment cell. It is recommended to remove that accumulation of water before it freezes to avoid damaging the geomembrane of the containment cell by ice accumulation.



The embankments around the tank farm containment areas was stable. Tension cracks observed in the past on the upper bench north of Tanks 3 and 4 and south of Tanks 5 and 6 are disappearing. The northern slope of the containment area of Tanks 5 and 6 are steep and the sand and gravel cover may be prone to erosion. This area should be periodically inspected for signs of erosion.

The fuelling station on the western side of the tank farm consists of two containers and a pumping system. The fuelling area is covered by granular road base material. The fuelling station was in good geotechnical condition.

A photographic log of the Baker Lake tank farm and a plan view that shows the location of the photos and observations is included in Appendix F1.

7.2 Meadowbank Tank Farm (Main Camp)

The Meadowbank Main Camp tank farm consists of a single large-capacity tank (5.6 million litres) constructed within an area that has been subexcavated to provide secondary containment. The area has been lined with a 1.5-mm HDPE geomembrane.

At the time of the inspection, the tank backfill foundation pad was in good condition. The liner was well covered with granular fill material for protection. The two small channels of erosion observed in the past within the tank platform had been repaired.

Water (approximately 50 mm) was observed ponding within the eastern corner where a small pump is periodically installed for dewatering. Signs of high water levels being present in this area in the past were noted during the inspection. Pumping of ponded water is considered a good practice and should continue.

A fuelling station is located on the northern side of the tank farm. The fuelling area is covered by granular road base material and a geomembrane liner is installed below the refuelling area. Small 3 m long tension cracks were observed during the inspection on top of the subexcavated area behind the fuelling station. It is recommended to inspect periodically this area for changing condition.

As the tank farm area has been subexcavated, runoff from the tank farm is not anticipated to occur. The side slopes in the tank area are shallow and appear stable.

Appendix F2 contains a photographic log and a plan view that shows the location of the photos and observations noted at the Meadowbank tank farm.

7.3 Meadowbank Tank Farm (Vault Pit Area)

The Vault tank farm consists of five tanks and was built in 2014. The retention basin is installed below the rockfill pad and is made of a geosynthetic clay liner. No geotechnical issues were noted with this structure.

Appendix F3 contains a photographic log and a plan view that shows the location of the photos and observations.

8.0 OTHER MEADOWBANK FACILITIES

This section contains the observations made for the other Meadowbank facilities visited during the 2016 geotechnical inspection such as the site roads, the diversion ditch and erosion protection structure, the RSF till plug, the diffusers, the landfill, the contaminated soil storage and bioremediation landfarm facility, the Stormwater



Management Pond, and the airstrip. Figure G1 shows the location of the photos taken during the inspection for the other Meadowbank facilities.

8.1 Site Roads

The following roads were inspected:

- East Road – Former haul road between North Portage Pit and East Dike;
- West Road – Haul road between North Portage Pit and the plant;
- Vault Road – Haul road between North Portage Pit and the Vault deposit;
- RF1 – Starts near the northern abutment of Stormwater Dike and follows the eastern perimeter of the TSF’s North Cell and the southwestern side of the Portage Rock Storage Facility;
- RF2 – Starts at the end of RF1 and follows the western side of the Portage Rock Storage Facility.

These roads were of adequate width and had appropriate berms at the time of the inspection. The haul road from Goose Pit to the plant was not inspected during this investigation. No geotechnical concerns were identified with East Road, West Road, RF1 and RF2.

Three culverts are installed beneath Vault Road at coordinates 640 964 E / 7 217 466 N. These three culverts were slightly collapsed in the middle and showed signs of erosion at the inlet. This condition was observed from 2012 to 2015. No action is required as their condition is stable. These culverts need to be monitored during freshet to ensure that they provide sufficient capacity and that erosion is not occurring. Two other culverts are located at 639 214 E / 7 216 189 N on Vault Road. It was observed that the inlet of one of these culverts was entirely obstructed by rockfill and that its outlet was broken, while the outlet of the other culvert was partially obstructed. It is recommended to observe this area at freshet and to clear the obstructions if insufficient capacity to handle the flow is observed.

Temporary roads developed for construction purposes were not inspected.

Appendix G1 contains photographs of the Vault Road culvert.

8.2 Diversion Ditches and Sediment and Erosion Protection Structure

A retention basin and a series of diversion ditches (Western and Eastern) surround the catchment basin of the North Cell. These structures are designed to convey surface water runoff away from the TSF.

Since 2014, the Western Diversion Ditch directs the water to a retention basin, which is then pumped to the North Cell due to a turbidity problematic caused by the erosion of the ditches. Rehabilitation work was done in 2016 to address the situation. The Eastern Diversion Ditch discharges to lake NP-2, then lake NP-1 and then to Dog Leg Lake. Sediment barriers and erosion protection structures are installed at the outlet of the diversion ditch in Lake NP-1, Lake NP-2 and Third Portage Lake (Dog Leg Lake).

During the inspection, it was observed that the diversion ditches around the TSF’s western and eastern extensions were in good condition. The erosion protection structure and sediment barriers were also in good condition at the time of the inspection. It is important that they be inspected prior to the freshet season.

Appendix G2 contains photographs of the diversion ditch and its sediment and erosion protection structure.



8.3 RSF Till Plug

The RSF till plug (till plug) is located on the upstream side of the Diversion ditches access road between the Waste Rock Storage Facility (RSF) and lake NP2. The till plug is a zoned low permeability earth fill structure intended to prevent seepage from the RSF to reach lake NP2 and to facilitate seepage collection on the upstream side.

The till plug was constructed in the summer of 2013. Its construction consisted in profiling the upstream slope and placing a 0.5-m-thick layer of compacted crusher reject, and then installing a geotextile membrane covered by 0.5 m of fine ultramafic rockfill and material reject from till sieving. Both granular layers were compacted with an excavator bucket.

No sign of erosion or geotechnical issues were identified with this structure during the inspection. A pump equipped with an automatic switch was installed within the pond contained by the plug to redirect the water to the North Cell. As the chemical monitoring in NP2 has not shown any signs of contamination for the last two year, the performance of the till plug is considered adequate.

Appendix G3 contains photographs of the till plug.

8.4 Diffusers

The objective of the diffuser is to return the water to the environment without eroding the shoreline. There is a diffuser at Vault (within Wally Lake), and there is no longer a diffuser at Portage Lake since 2015.

During the inspection, it was observed that the diffuser at Vault had moved in a less deep water location which resulted that the pipe is now showing out of the water and the water is spraying out. No damage to the shoreline or the lake bottom was observed. It is recommended to repair this diffuser so that the pipe is entering the lake in order to reduce the risk of shoreline erosion. Per AEM, the diffuser were removed and they mandated an external firm for recommendation about the installation of that diffuser for next year.

Appendix G4 contains photographs of the diffuser.

8.5 Landfill

The Meadowbank landfill is located on the northeastern side of the TSF, within the Portage RSF area. It is progressively being constructed and filled. Waste material is being dumped within a bermed area on a pad built using waste rock from the open pit. The waste is then covered with a thin layer of rockfill to reduce windblown debris. No geotechnical concerns were identified with the landfill. Appendix G5 contains photographs of the landfill.

8.6 Contaminated Soil Storage and Bioremedial Landfarm Facility

The Meadowbank Contaminated Soil Storage and Bioremedial Landfarm Facility is located on the downstream side of Stormwater Dike within the TSF's South Cell close to the Water Treatment Plant (WTP). This structure has been relocated nearby within the South Cell in the summer of 2016 to allow the construction of the Stormwater Dike stabilisation buttress.

A 1 m thick till pad has been placed for the landfarm foundation. A berm surrounds the landfarm to contain the fluid/runoff and stops it from moving laterally. Contaminated soils are stored within this cell to promote biodegradation until the soil meets environmental criteria before being disposed within the Portage Rock Storage Facility.



No geotechnical concerns were identified with this structure. Appendix G6 contains photographs of the Contaminated Soil Storage and Bioremedial Landfarm Facility.

8.7 Stormwater Management Pond

The Stormwater Management Pond is located near the main camp and is being used to store various site waters and sewage. No runoff from the pond was observed at the time of the inspection. No geotechnical concerns were identified with Stormwater Management Pond and the nearby crusher ramp. Due to the proximity of the crusher ramp to the pond, it is recommended that regular geotechnical inspections of the crusher ramp be conducted.

No geotechnical concerns were identified with this structure. Appendix G7 contains a photographic log of Stormwater Management Pond.

8.8 Airstrip

There are several small channels dug adjacent to the airstrip to divert water into small excavations or “ponds.” The channels and ponds are unlined, and the ponds have no designed outlet structure. In general, these ponds serve to collect water and allow suspended sediments to settle out before the water overflows into other vegetated areas and/or infiltrates them, depending on the thermal state of the soils.

The runway was extended in the winter of 2013 at both ends to allow a Boeing 737-200 to land at the Meadowbank site. The northwestern boundary of the airstrip extends approximately 20 m within the lake and was constructed in two phases. Rockfill was placed 1.0 m above water during Phase 1 and the rockfill was constructed to its final elevation during Phase 2. The rockfill slopes for Phase 2 have a side slope of 1.5H:1.0V. The rockfill of Phase 2 is surrounded by a 17.0-m-wide bench going from the toe of Phase 2 to the edge of the crest of Phase 1. The Phase 1 rockfill surface and visible side slope were built with coarse boulders to protect the embankment against waves and ice action. The airstrip construction within the lake is considered appropriate.

No geotechnical concerns were identified with this structure during the inspection. Appendix G8 contains a photographic log of the airstrip.

9.0 SUMMARY AND RECOMMENDATIONS

The following presents a summary of the key findings and recommendations of the 2016 geotechnical inspection.

9.1 Dewatering Dikes

- The current versions of the Operation, Maintenance and Surveillance (OMS) Manual (AEM, 2016), including the Emergency Preparedness Plan (EPP), and of the overall Emergency Response Plan (ERP) for the mine (AEM, 2016c) are dated March 2016 and August 2016. It is a good practice to keep these documents up to date.
- The condition of the dewatering dikes is regularly inspected by the mine and this practice should continue.

East Dike

- Regular monitoring and assessment of the monitoring data (piezometric, thermal, inclinometer, flow meter and seismograph) should continue. Due to technical problems with dataloger, the piezometer and thermistor data from June 2016 to September 2016 are missing between Sta.60+240 and 60+700. As a results, partial



pore water pressure or temperature data are available for the thawing period of 2016. It is recommended to fix the issue with these instruments to continue obtaining data. It is recommended to flag the piezometers that recorded data below 0°C in the past and be very careful when interpreting their data as they might be broken.

- No signs of slope instability, erosion and tension cracks were observed on the structure. Based on visual inspection and the instrumentation data, the condition of East Dike appears stable.

South Camp Dike

- South Camp Dike was in good condition and no geotechnical concerns were identified.
- It is recommended to continue keeping the downstream toe of the dike clear to facilitate inspection. The nearby ultramafic rock dump should not obstruct the toe of the dike.

Bay-Goose Dike

- The tension cracks observed in 2013 and 2014 on the upstream side within the thermal cap were still visible but are no longer active. The settlement within the thermal cap was observed but did not show any additional sign of movement since 2013. The area should continue to be monitored to make sure there are no aggravating conditions developing.
- Regular monitoring and assessment of the monitoring data (piezometric, flow, thermal, inclinometer, and seismograph) should continue. It is recommended to flag the piezometers that recorded data below 0°C in the past and be very careful when interpreting their data as they might be broken. Once a piezometer has frozen, it cannot be relied upon even if it thaws.
- Water ponds were observed at the downstream toe during the inspection. It is recommended to pump them periodically to allow for good visual inspection of the downstream toe. The pond flow formed by seepage should be monitored and recorded.
- Overall seepage is less than anticipated and is not a concern for now. The inflow of water from the pond at Central Channel should be monitored.
- North Channel, Channel 1 and Channel 3 should be carefully monitored and inspected. Limited evidence of seepage is observed at the downstream toe of these channels. The instrumentation data and field observations seem to indicate that seepage occurs at these locations but reports directly to the Pits instead of the downstream toe area. The seepage being reported to the Pits should be included in the Bay-Goose Dike seepage statistics.
- Further assessment is required to assess the impact of Portage Pit mining on the stability of Bay-Goose Dike as the North Channel piezometer seems to react to E3/E4 activity. This assessment is underway by AEM.
- At the time of the site inspection, and based on the instrumentation data collected up to that time, the condition of Bay-Goose Dike seems stable.

Vault Dike

- Vault Dike was in good condition at the time of the inspection. The settlement and cracks observed in 2013 and 2014 were not noticeable anymore. No new issues were observed.
- Regular monitoring and assessment of the thermistor data should continue.



9.2 Tailings Storage Facility

- The most current versions of the Operation, Maintenance and Surveillance (OMS) Manual (AEM, 2016b), including the Emergency Preparedness Plan (EPP), and of the overall Emergency Response Plan (ERP) for the mine (AEM, 2016c) are dated March 2016 and August 2016. It is a good practice to keep these documents up to date.
- At the time of the inspection, the peripheral structures of the TSF North Cell had an adequate tailings beach against them. Water was observed ponding against the northern portion of Central Dike as tailings deposition from Central Dike was stopped during the 2016 construction season. AEM is planning to quickly restore the tailings beach against Central Dike per the design requirement.
- Regular visual inspection as well as collection and regular review of instrument data should continue for all structures within the TSF.

Saddle Dam 1

- No visual signs of slope instability, erosion or tension cracks were observed.
- The environmental department should continue monitoring the water quality and share this information with the engineering department.

Saddle Dam 2

- Water was observed on the downstream side ponding within the rockfill embankment between Sta. 20+275 and Sta. 20+475. It is recommended to install a thermistor within this sector and to be on the lookout for signs of change in the thermal regime of the foundation.
- No visual signs of slope instability, erosion or tension cracks were observed.

Stormwater Dike

- Several tension cracks associated with movement were observed on the crest from Sta. 10+500 to 10+750. These movements appeared in August 2016 shortly after water from the South Cell reached this sector and stabilized, then stopped shortly after a rockfill buttress was constructed at the toe on the downstream side in September 2016. The observed movements are happening in a sector where the dike was built on frozen soft sediment and were probably caused by the water thawing this soft layer. The MDRB recommended that more instruments be installed, that a better understanding of the foundation be obtained through a geotechnical investigation, and that design criteria be established for the mitigation measure put in place.
- Shallow water (30 cm deep) was observed ponding against a portion of Stormwater Dike in the North Cell. This small accumulation of water against the dike is not considered a problem.
- A small hole in the bituminous geomembrane was observed at approximately Sta. 10+200. A punctured water balloon in the liner was also observed at 10+380. These two areas were repaired after the inspection.

Central Dike

- Tailings deposition from Central Dike stopped during the 2016 construction season. Tailings deposition from the structure was planned to resume in October 2016 to promote a tailings beach against the structure.



- Seepage from the South Cell is ponding on the downstream side of Central Dike. At the time of the inspection, the water was clear and an average flow of approximately 550 m³/hr was pumped back to the South Cell to maintain the downstream pond at El. 115 m. AEM is working closely with the MDRB and the dike designer (Golder) to determine the seepage pathway and to establish measures to keep the situation under control. Golder recommends: 1) maintaining a tailings beach against Central Dike, 2) controlling the hydraulic gradient by proper management of the South Cell water pond and dike downstream toe pond, 3) closely monitoring the water quality; and 4) inspecting the structure for changing conditions.

Saddle Dams 3 and 4

- These structures are in good geotechnical condition. They were not operational at the time of the inspection as they were not retaining tailings and water.
- During the inspection, water was observed ponding on the downstream side of Saddle Dam 3 and Saddle Dam 4. As the downstream toe is higher than the South Cell pond, this water does not come from the TSF. It is important to maintain the water level on the downstream side lower than the granular layer of the upstream toe liner tie-in granular material to prevent uplift of the geomembrane. As the elevation of the downstream side is lower than the elevation of the granular material, this should not be a problem if the downstream water level is managed. The management of this water could be simplified by the construction of a sump, as indicated in the construction drawings, to direct the water in a low point.

9.3 All-Weather Private Road

- No geotechnical issues were identified with the AWPR at the time of the inspection that were related to thermal degradation of the permafrost, thaw settlement, erosion of the road materials, or sediment migration from the road into adjacent watercourses.
- Regular inspections and maintenance of the road by AEM should continue. Consideration should be given to expanding AEM's monitoring program to include all culverts and bridges along the road in order to assess whether they are providing adequate capacity during the freshet and following large precipitation events.
- AEM has been conducting regular and event-based inspections of the fish-bearing water crossing locations along the road and these should continue in order to confirm the hydraulic function of the crossings, adequacy of crossing locations with respect to the watercourses, and minimal impact to fish habitat.
- The erosion of the culverts is stable. The progression of the erosion of culverts PC-17A (8+830), R14 (67+840), R18-B, R-20 (85+490), R-23(93+600) and R24 (98+100) should be monitored at freshet for any signs of progression or washout, as signs of water flowing beneath the road were observed at these locations.
- For some culvert locations, monitoring is recommended to see if flow occurs through the culvert (i.e. during the freshet). If insufficient capacity to handle the flows is observed, or water circulates under the road, then it is recommended to clear the obstructions or repair the culverts. Particular attention should be paid to R-00A (km 2+550), the culvert at 5+700, PC-14 (km 4+260), and PC-16 (km 54+950).
- The inspected bridges and their embankments were in good geotechnical condition. Signs of settlement were observed at Bridge 6, R15. The bridge was dipping toward the western side on both abutment. The bridge foundation did not show signs of adverse conditions. It is recommended to monitor the situation.



9.4 Quarries

- Most quarries have been cleaned since the 2015 inspection. Loose blocks and granular material have also been removed from the quarry walls. Slope remediation is in progress, but none of them were totally reclaimed. It is understood that AEM is developing a plan to progressively close some of the quarries along the AWPR while maintaining others to produce and store material supplies for ongoing road maintenance.
- Presence of unstable blocks and loose rocks along steep walls was observed in Quarries 3,7, 9, 10, 12, 16, and 23. It is recommended that workers be cautious in these quarries and are aware of the potential hazard.
- Quarries 4 and 14 are flooded. It is understood that AEM is evaluating how best to eliminate the ponding of water within these quarries.

9.5 Bulk Fuel Storage Facilities

- Ponded water within the secondary containment cell was observed at the Baker Lake and Meadowbank main camp fuel tank farm. Ongoing removal of water should be managed to keep the water accumulation at a minimum near the tank foundation.
- The granular fill material protecting the geomembrane was eroded at Baker Lake due to wave actions in some areas, exposing the geomembrane. This condition was observed all along the south side of Tanks 3 and 4 and on the west side of Tank 1. It is recommended to cover the exposed area with geotextile and fill material to re-establish the liner protection.
- A hole in the exposed geomembrane (300 mm diameter hole) was observed at Baker Lake on the south southwestern corner of Tank 3 at the toe of the slope. The hole in the geomembrane should be repaired to ensure a good performance of the retention basin.
- The embankments around the Baker Lake tank farm containment areas were stable. Tension cracks observed in the past on the upper bench north of Tanks 3 and 4 and south of Tanks 5 and 6 are disappearing. The northern slope of the containment area of Tanks 5 and 6 should be inspected periodically for signs of erosion.
- The geomembrane remains uncovered around the tanks of the twenty Jet A fuel tanks at Baker Lake. It is recommended to remain vigilant during the freshet and throughout the year to manage water accumulated within the bermed area.
- A 3 m long tension crack was observed at the Meadowbank Main Camp tank farm on top of the subexcavated area behind the fueling station. It is recommended to monitor this area for changing conditions.
- No geotechnical issues were noted with the Meadowbank Vault tank farm.

9.6 Other Meadowbank Facilities

Meadowbank Site Roads

- Haul roads currently in operation are of adequate width and have appropriate berms.
- Three culverts were installed on Vault Road (coordinates 640 964 E / 7 217 466 N). As previously observed in past annual inspections, these three culverts were partially collapsed in the middle and showed signs of



erosion at the inlet. This is currently not a significant issue, but it is recommended to monitor these culverts at freshet to ensure that they provide sufficient capacity and that erosion is not occurring.

- Two culverts are installed on Vault Road (coordinates 639 214 E / 7 216 189 N). It was observed that the inlet of one of the culverts was entirely obstructed by rockfill and that the outlet of one of the culvert was partially obstructed while the outlet of the other culvert was broken. It is recommended to observe this area at freshet and to clear the obstructions if insufficient capacity to handle the flow is observed.

Diversion Ditch and Sediment and Erosion Protection Structure

- No geotechnical concerns were observed with this structure.
- It is important that the erosion protection structure and sediment barriers be inspected during freshet season.

RSF Till Plug

- No geotechnical issues were observed with the RSF till plug.

Diffuser

- The diffuser at Wally Lake had moved to a less deep water location and was spraying water in the air. It is recommended to repair this diffuser so that the pipe is entering the lake to reduce the risk of shoreline erosion.
- AEM removed the diffuser and mandated an external firm for recommendation about the installation of that diffuser for next year.

Landfill and Contaminated Soil Storage and Bioremedial Landfarm Facility

- No geotechnical concerns related to the landfill or the landfarm were identified at the time of the inspection.

Stormwater Management Pond

- No geotechnical concerns were identified regarding the Stormwater Management Pond, or the crusher ramp located nearby. The geotechnical stability of the crusher ramp should be regularly inspected by AEM due to its proximity with Stormwater management pond.

Airstrip

- No geotechnical concerns were identified with the airstrip.



10.0 CLOSURE

This report was prepared to summarize the findings from the 2016 geotechnical inspection conducted by Golder between September 8 and September 15, 2016, to comply with the requirements of AEM's Type A Water Licence Permit No. 2AM-MEA0815, Part I, Item 12. An inspection of the pit walls is reported under separate cover.

We trust the above information is sufficient for your current needs. Should you require additional information or further clarification, please contact us.

GOLDER ASSOCIÉS LTÉE

ORIGINAL SIGNED

Frédéric L. Bolduc, Eng., M.Sc.
Geotechnical Engineer

ORIGINAL SIGNED AND SEALED

Yves Boulianne, P.Eng.
Geotechnical Specialist, Associate

FLB/jlm/YB/

Golder, Golder Associates and the GA globe design are trademarks of Golder Associates Corporation.

n:\actif\2016\3 proj\1662181 aem geotech insp 2016 meadowbank\5 preparation of deliverables\doc 1549 2016 geotechnical inspection\rev 0\doc 1549 1662181 rev0 2016 geotechnical inspection.docx



11.0 REFERENCES

- Agnico-Eagle Mines Ltd., Meadowbank Division, 2016a. "Dewatering Dikes Operation, Maintenance And Surveillance Manual". Version 5. March 2016.
- Agnico-Eagle Mines Ltd., Meadowbank Division, 2014. "Emergency Response Plan, Meadowbank Gold Project". Version 9. November 2014.
- Agnico-Eagle Mines Ltd., Meadowbank Division, 2016b. "Tailings Storage Facility Operation, Maintenance And Surveillance Manual". Version 6. March 2016.
- Agnico-Eagle Mines Ltd., Meadowbank Division, 2016c. "Meadowbank Gold Project Emergency Response Plan". Version 10. August 2016.

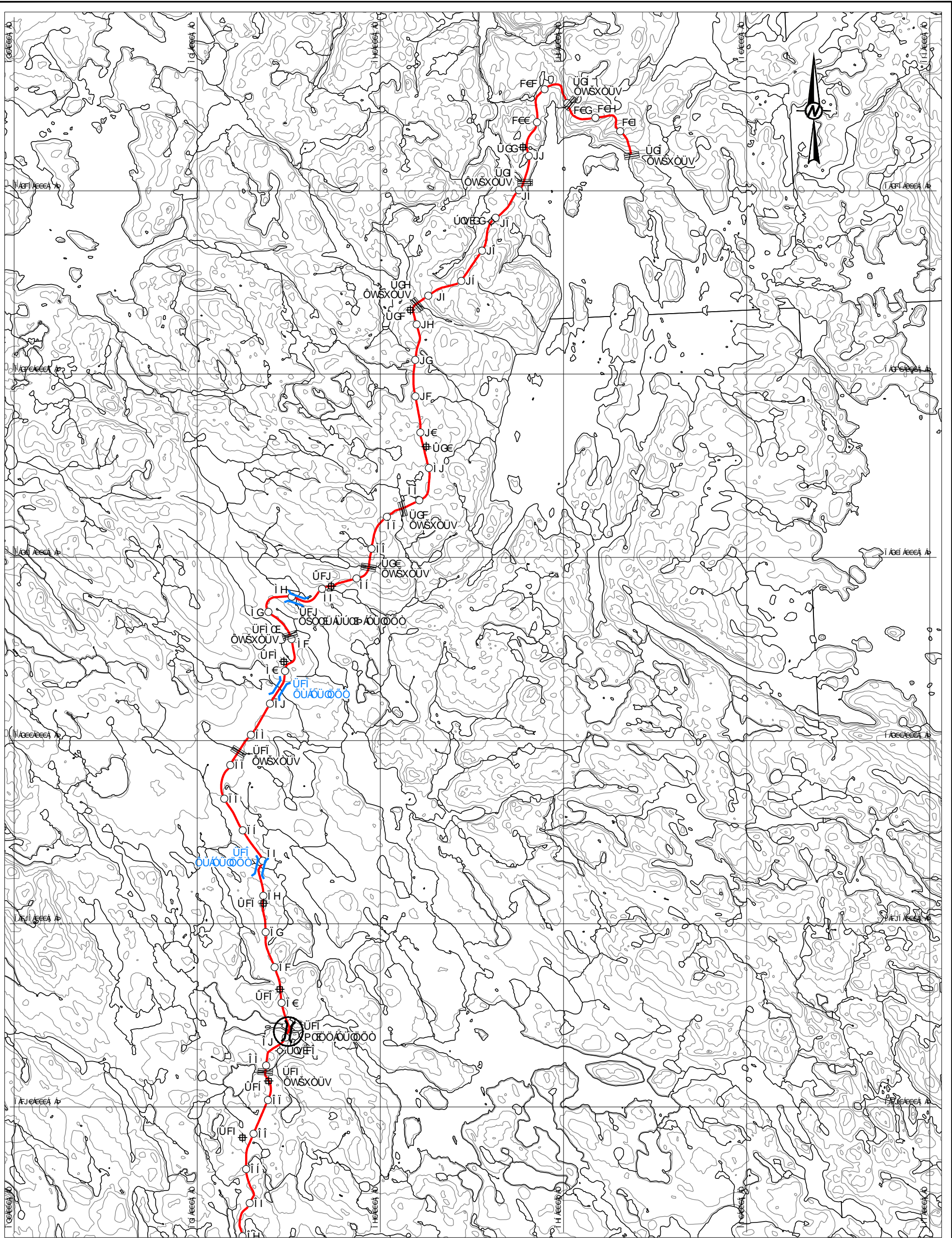

05000

ΥΠΟΥΡΧΟΝ
 ΓΕΦΙ ΑΠΕΡΩΣΑΘΟΥ ΟΟΡΡΩΕΣΑΡ ΠΥΟΟΝΩΡ
 Τ ΟΑΘΥ ΟΕΣΑΘΟΥ ΣΑΤ ΟΘΕΡΩΡΟΚΩ

ΥΠΟΥΡΧΟΝ
 5 @ K 95 H < 9 F ' D F - J 5 H 9 ' F C 5 8 Α

ΟΥΠΩΣΩΡ

ΥΠΟΥΡΧΟΝ	ΓΕΦΙ ΕΕΕΕ
ΥΠΟΥΡΧΟΝ	ΟΕΣΑΘΟΥ (α' &
ΟΟΥΩΡ	ΥΘΑΓ Α' Λ'
ΥΟΧΩΡ	ΟΕΣΑΘΟΥ (α' &
ΑΥΠΟΥΧΟΝ	ΥΘΑΓ (αα) Λ'



ΥΠΟΥΡΧΟΝ Ε
 ΠΙ ΓΕΦΙ
 ΥΠΟΥΡΧΟΝ
 Ι ΕΕΕ
 ΥΑΓΕ
 €
 ΟΩΩΩ
 GO

- ΣΥΜΒΟΛΟ
- ΟΔΟΣ
 - ΡΑΒΔΟΔΥΜΟΣ
 - ΟΣΟΑΕΥΣΑΘΟΥ
 - ΟΥΑΦΘΟΑΥΑΕΥ
 - ΣΑΥΤΟΝΟΥΑΤΑΙΣΟΥ
 - ΥΑΦΧΟΥΩΑΘΟ

ΥΟΧΩΡΟΘΟ
 ΡΑΥΑΘΑΘΕΩΡΤΟΒΝΘΟΥΘΟΘΩΝΣΧΟΥΑΠΘ
 ΟΥΑΕΥΣΑΘΟΥ ΟΑΘΟΥ ΤΑΡΩΑΘ ΒΝΑΘΟΥΧΘΟΥ
 ΣαΕ
 ΑΥΠΟΥΣΑΘΟΥ ΟΑΘΟΥ ΤΑΡΩΑΘΟΥ ΑΥΑΘΟΥ ΟΥΑΘΟΥ
 ΟΥΠΩΑΘΟΕ





APPENDIX A

Dewatering Dikes



APPENDIX A1

East Dike Photographic Log and Record of Inspection



5 DD9 B8 ± 5 %
F97 CF8 'C: '8 5 A 'BGD97 H-CB''

'BGD97 H-CB' #9A '	C6 G9 FJ5 H-CBG' 85 H5'	D<CHC'	7 CAA9 BHG/ 'CH<9F'85 H5'
) "56I HA9 BHGÁ	Á	Á	Á
í ÈÁ Ù^> æ^&^&{ } æ&Á[]^Á Çæ ð ^) Ð{ àæ\{ ^) ÐÁ	Þ[]^Á à•^!ç^áÁ	Á	Á
í ÈÁ Ùæ }•Á-Á![]Á	Þ[]^Á à•^!ç^áÁ	Á	Á
í ÈÁ Ò&••æ^&^*^ææ }Á	Þ[Á	Á	Á
í ÈÁ Ù!•^> &^&-Á[á^> á à~!![, •Á	Þ[]^Á à•^!ç^áÁ	Á	Á
í ÈÁ U@!Á }~•~ æ&{ } áææ }•Á	Þ[]^Á	Á	Á
* "F9G9 FJC-FÁ	Á	Á	Á
í ÈÁ Ùææææ Á-Á[]^•Á	Ùææ^Á	Á	Š, Á^&-Á^*æ } Èææ^Á }•d^æ ææ áÁ á[]•d^æ Á-Áæ^ÈU[]:æ^ÁJææ Á } Á@Á á[]•d^æ Áæ^Á-Á@Áæ^È
í ÈÁ Öæ ææ &^& Á^æ^•ó[]æ^Á Çææ } ææ^Á	Þ[]^Á à•^!ç^áÁ	Á	Á
í ÈÁ Ò-æ æ^&-Á[]æ^&[]^ ^Á Çææ } ææ^Á	Þ[ææ] ææ^Á	Á	Á
í ÈÁ Ø[] ææ *Á^à!áÁ	Þ[]^Á à•^!ç^áÁ	Á	Á
í ÈÁ U@!Á }~•~ æ&{ } áææ }•Á	Þ[]^Á	Á	Á
+ "9A9F; 9B7 MGD=@@K 5M# CI H@H'GHFI 7HI F9Á	Á	Á	Á
í ÈÁ Ù!-æ&^&{ } áææ }Á	Þ[Á] æ, æ&!Á~d^ó •d~&c!^Á çæ •È } ^Á á^, æ&!æ*Á~{]Á	Á	Á
í ÈÁ Ùæ }•Á-Á![]Á	Á	Á	Á
í ÈÁ Ùæ }•Á-Á [ç^> ^) á Çæ^![] ææ }ÐÁ	Á	Á	Á
í ÈÁ Ò!ææ•Á	Á	Á	Á
í ÈÁ Ù^ç^> ^) á	Á	Á	Á
í ÈÁ Ù!•^> &^&-Á^à!á Á!Á à[] &æ^Á	Á	Á	Á
í ÈÁ Ò[]~ ^Á ^&@æ á{ Á []^!ææ }æÁ	Á	Á	Á
í ÈÁ Ù[]^Á![] ç&ç }Á	Á	Á	Á
í ÈÁ Q•ææææ Á-Áæ^Á[]^•Á	Á	Á	Á
í ÈÁ U@!Á }~•~ æ&{ } áææ }•Á	Þ[Á	Á	Á



5 DD9 B8 ± 5 %
95 GH'8 ± 9 'D<CHC; F5 D<7 'C; '



Ú@d *!aj @ÜFËÖe oÖä^Á

8 UHÁ^] c{ à^!ÁGÖEÍ Á

D\ ch'Bi a VYfKì Á

8 YgW]dhcbkQ [{ Áq]! cā æ^ ÁcaÄ EÉH í Eñ [\ā * Á [~ cāá@ Á^• dÄ



Ú@d *!aj @ÜFËÖe oÖä^Á

8 UHÁ^] c{ à^!ÁGÖEÍ Á

D\ ch'Bi a VYfKì JÁ

8 YgW]dhcbkQ [{ Áq]! cā æ^ ÁcaÄ EÉI FÉñ [\ā * Á [| cāá@ Á^• dÄ



5 DD9 B8 ± 5 %
 95 GH'8 ± 9 'D<CHC; F5 D<7 'C; "



Á

Ú@q *!æj @UEH Aoe oÖa^Á

8 UHYÁ] c{ à\!Á FGEFÍ Á

D\ chc 'Bi a VYfÁGJHÁ

8 YgW]dhcbkQ [{ Áq]!| cā æ\ ÁcaÄ EÍ I EÄ [\ā * Á [! cā@ Á\^ dÄ



Á

Ú@q *!æj @UEH Aoe oÖa^Á

8 UHYÁ] c{ à\!Á FGEFÍ Á

D\ chc 'Bi a VYfÁGJ I Á

8 YgW]dhcbkQ [{ Áq]!| cā æ\ ÁcaÄ EÍ I EÄ [\ā * Á [cā@ Á\^ dÄ



5 DD9 B8 ± 5 %
95 GH'8 29 'D<CHC; F5 D<7 'C; "



Á

Ú@q *!æj @UEË ÁæoÖá^ÁÁ

8 UHYÁ^] c{ à^!ÁFGÖEFÍ Á

D\ chc 'Bi a VYfKJGÁ

8 YgW]dhcbkQ[{ Áq]| cā æ| ÁcaË ÉÍ | ÉÁ]•d^æ Ë[[\ā * Á [~ c@á@Á & !•áq á@Á]•d^æ Á [] ^ËÁ



Á

Ú@q *!æj @UEË ÁæoÖá^ÁÁ

8 UHYÁ^] c{ à^!ÁFGÖEFÍ Á

D\ chc 'Bi a VYfKJGÁ

8 YgW]dhcbkQ[{ Áq]| cā æ| ÁcaË ÉÍ | ÉÁ]•d^æ Ë[[\ā * Á [~ c@á@Á]•d^æ Á [] ^ËÁ



5 DD9 B8 ± 5 %
95 GH'8 ≈ 9 'D<CHC; F5 D<7 'C; "



Á

Ú@q *!æ @UEË Áæ oÖá^Á

8 UYKÁ] c{ à!Á FÉCFÍ Á

D\ chc 'Bi a VYfKÍ Á

8 YqW]dhcbkQ [{ Áæ]! cā æ' ÁcaË ÉÍ FÉÁ [\ā * Á [~ cā@Á & ^ oā á@Á] • d^æ Á [] ^É



Á

Ú@q *!æ @UEË Áæ oÖá^Á

8 UYKÁ] c{ à!Á FÉCFÍ Á

D\ chc 'Bi a VYfKÍ Á

8 YqW]dhcbkQ [{ ÁcaË ÉÍ FÉÁ] • d^æ É [\ā * Á [cā] * Á@Á] • d^æ Á [] ^É



5 DD9 B8 ± 5 %
95 GH'8 29'D<CHC; F5 D<7'@; "



Ú@d *!æ @ÜFËÄÖoÖÄ^ÄÄ

8 UHYÄ^] c{ à\!ÁÉÖFÍ Á

D\ ch'Bi a VYfKÍ Á

8 YgW]dhcbkQ[{ Äq]| cä æ\ ÁcÄ ÉGÍ ÉÄ [\ä * Á ^ ÖÄ@Ä, ^ ÖÄ ä@Ä] • d^æ Ä [| ^Ä



Ú@d *!æ @ÜFËÄÖoÖÄ^ÄÄ

8 UHYÄ^] c{ à\!ÁÉÖFÍ Á

D\ ch'Bi a VYfKÍ Á

8 YgW]dhcbkQ[{ Äq]| cä æ\ ÁcÄ ÉGÍ ÉÄ [\ä * Á ^ ÖÄ@Ä, } • d^æ Ä ä^Ä ä@Ä ^Ä



5 DD9 B8 ± 5 %
 95 GH'8 29'D<CHC; F5 D<7'@; "



Á

Ú@d *!æ @ÜFËF@e oÖa^Á

8 UYKÁ] c{ à^!ÁGÖEÍ Á

D\ chc'Bi a VYfKJÍ Á

8 YgW]dHcbKQ [{ Áq] | | cã æ | ÁcaÄ €ÉH €Ä [\ | ä * Á [~ c@e@Á & ^ o Áq á@Á [,) • d^æ Á q^Ä



Á

Ú@d *!æ @ÜFËG@e oÖa^Á

8 UYKÁ] c{ à^!ÁGÖEÍ Á

D\ chc'Bi a VYfKJÍ Á

8 YgW]dHcbKQ [{ Áq] | | cã æ | ÁcaÄ €ÉÍ €Ä [,) • d^æ Ä [\ | ä * Á [~ c@e@Á [,) • d^æ Ä ^Ä



APPENDIX A2

South Camp Dike Photographic Log and Record of Inspection



5 DD9 B8 ± '5 &
F97 CF8 'C: '8 5 A 'BGD97 H-CB'

7`JYbh` œÓT Á 6 m` Ýç^•ÁÓ[~ |æ] } ^Á
 Dfc`YWh` T ^æ[, àæ \ Á 8 UH.` Û] ç{ à!Á ÆGEFÍ Á
 @WUjcb.` Û[~ œÓæ] Áö^Á F Yj]Yk YX.` Ýç^•ÁÓ[~ |æ] } ^Á

; 9B9F5 @-B: CFA5 H-CB'

8 Ua `HndY.` Ü[& ç[Á @||Á æÓÁ] •d^æ Áç[Æææ { ç[~ •Á^[{ ^{ àæ ^Áç ^!Áæ } áÁ[| ç&ç^Áç ç^!ÆÁ
 K YUH Yf '7 cbX]jcbg.` Üæ ^ Á HYa dYfUi fY.` Í »ÔÁ

'BGD97 H-CB' #9A`	C6 G9 F J 5 H-CBG` 85 H5`	D<CHC`	7 CAA9 BHG/` CH<9F`85 H5`
%85 A`7 F9 GH		G ĒHEÁ	
FÈÁ Ô!^•d^çæ] } Á	ÒÈFH È Á Áç[& ç[Á ÒÈFH È Á Áç ^!Á		
FÈÁ Ü^•^ç[á^ç^Á	WUÁÒÈFH È Á Á ÒÈFH		P[Á æ^!Á à^ç^áæ[,] •d^æ Á ^Á •ç & ÁGEFFÁ
Ô` ^} ç^à[æáÁ	HÁ Áç[& ç[Á^•d^ FÈÁ Áç ^!Á^•d^		
FÈÁ Öæ çæ & Á çæç *•Á[] áÁ ç[ç] ææ ^Á	P[çæ] ææ ^Á		
FÈÁ Û`!-æ^Áæ ç *Á	P[] ^Áæ@ç ^Á-Á ç•]^&ç] Á		
FÈÁ Wj ^ç[^&ç^á^ç^ ^{ ^} ç	P[] ^Áæ@ç ^Á-Á ç•]^&ç] Á		
FÈÁ Šæ^ç[[ç^ ^} ç	P[çæ] ç^ ç		
FÈÁ Uç!Á} ~ • ç[] áæç } •Á	P[] ^Á		
&'I DGHF95 A`G@CD9		G ĒFÁ	
GEÁ Û[] ^Áç *^Á	Ç[] çÈÈ-XIçPÁ		Çá^~ çÁ
GEÁ Ûæ } •Á-Á[] •ç } Á	P[] ^Á à^ç^áÁ		
GEÁ Ûæ } •Á-Á [ç^ ^} ç ç^!{ çæ] Á	P[] ^Á à^ç^áÁ		
GEÁ Ô:æ & Á	P[] ^Á à^ç^áÁ		
GEÁ çæ^Áç ^!Á[] áæç } Á ç[ç] ææ ^Á	Šá ^!Á [çç æ ^Áæ@Á ç ^Á-Á@ç] ^&ç] Á		Óæ { ç[~ •Á^[{ ^{ àæ ^Áç ^!Á Ô[{] æç^áÁç ~ æÁ æ^!Á ç^áÁ ç@ à^} ç] ç^ ç Á æ^áæ[ç^Á@ç ^!Á - , ^áÁ^æ@{ ç[ç ç^!Áç ç^!ç *Á ç@Á } ç^Áç ^!Áæ^Á





**5 DD9 B8 ± '5 &
F97 CF8 'C: '8 5 A 'BGD97 H-CB'**

'BGD97 H-CB' ±H9A'	C6 G9 F J 5 H-CBG' 85 H5'	D<CHC'	7CAA9BHG/ 'CH<9F'85H5'
ĈĤÁ U@!Á}~•~ ǎǎǎ } ǎǎǎ }•Á	P[]^Á		
' "8CK BGHF95A 'G@CD9		G ĚGJÁ	
HĚÁ Û[[]^ǎǎ }•ǎǎ	ĈĤ]! ĈĤĚ XĤPÁ		ĈĤ^~ ǎǎÁ
HĚÁ Ûǎ }•ǎǎ-ǎǎ!{•ǎ }Á	P[]^ǎǎ à•ǎǎĤǎÁ		
HĚÁ Ûǎ }•ǎǎ-ǎǎ [Ĥ^ { ^} ǎǎ ĈĤ^!{ ǎǎǎ }ǎ	P[]^ǎǎ à•ǎǎĤǎÁ		
HĚÁ Ôǎǎ•Á	P[]^ǎǎ à•ǎǎĤǎÁ		
HĚÁ Û^ǎ }ǎǎǎǎǎǎǎǎǎǎǎǎǎǎ	P[ǎǎǎ]ǎǎǎ }ǎ		
HĚÁ X^*^ǎǎǎǎǎǎǎǎǎǎǎǎǎǎ	P[Á		
HĚÁ U@!Á}~•~ ǎǎǎ } ǎǎǎ }•Á	P[]^Á		
(' "8CK BGHF95A 'HC9'5F95		G ĚGJÁ	
ĤĚÁ Û^ǎ }ǎǎǎǎǎǎǎǎǎǎǎǎǎǎ	P[]^ǎǎ à•ǎǎĤǎÁ		
ĤĚÁ Ûǎ }•ǎǎ-ǎǎ!{•ǎ }Á	P[]^ǎǎ à•ǎǎĤǎÁ		
ĤĚÁ Ûǎ }•ǎǎ-ǎǎ!{ǎǎǎǎǎǎǎǎǎǎǎǎǎǎ •^ǎ }ǎǎǎǎǎǎǎǎǎǎǎǎǎǎ	P[]^Á		
ĤĚÁ Öǎǎǎ {ǎǎǎ }ǎǎǎǎǎǎǎǎǎǎǎǎǎǎ	P[Á		
ĤĚÁ Û^ǎǎǎǎǎǎǎǎǎǎǎǎǎǎǎǎǎǎǎǎǎǎǎǎ ǎǎǎǎǎǎǎǎǎǎǎǎǎǎǎǎǎǎǎǎǎǎǎǎǎǎǎǎǎǎ	P[ǎǎǎ]ǎǎǎǎǎǎǎǎǎǎǎǎǎǎ		
ĤĚÁ U@!Á}~•~ ǎǎǎ } ǎǎǎ }•Á	P[]^Á		
) "56I HA9BHG			
ĤĚÁ Û^ǎ }ǎǎǎǎǎǎǎǎǎǎǎǎǎǎǎǎǎǎǎǎǎǎǎǎ ǎǎǎǎǎǎǎǎǎǎǎǎǎǎǎǎǎǎǎǎǎǎǎǎǎǎǎǎǎǎ	P[]^ǎǎ à•ǎǎĤǎÁ		
ĤĚÁ Ûǎ }•ǎǎ-ǎǎ!{•ǎ }Á	P[]^ǎǎ à•ǎǎĤǎÁ		
ĤĚÁ Öǎǎǎ•ǎǎǎǎǎǎǎǎǎǎǎǎǎǎǎǎǎǎǎǎǎǎǎǎ	P[Á		
ĤĚÁ Û!^•^ }ǎǎǎǎǎǎǎǎǎǎǎǎǎǎǎǎǎǎǎǎǎǎǎǎ ǎǎǎǎǎǎǎǎǎǎǎǎǎǎǎǎǎǎǎǎǎǎǎǎǎǎǎǎǎǎ	P[]^ǎǎ à•ǎǎĤǎÁ		
ĤĚÁ U@!Á}~•~ ǎǎǎ } ǎǎǎ }•Á	P[]^Á		
* "F9G9FJC=F			
ĤĚÁ Ûǎǎǎǎǎǎǎǎǎǎǎǎǎǎǎǎǎǎǎǎǎǎǎǎ	Ûǎǎǎǎǎǎǎǎǎǎǎǎǎǎǎǎǎǎǎǎǎǎǎǎ		
ĤĚÁ Öǎǎǎǎǎǎǎǎǎǎǎǎǎǎǎǎǎǎǎǎǎǎǎǎǎǎǎǎǎǎ ǎǎǎǎǎǎǎǎǎǎǎǎǎǎǎǎǎǎǎǎǎǎǎǎǎǎǎǎǎǎ	P[ǎǎǎ]ǎǎǎǎǎǎǎǎǎǎǎǎǎǎ		
ĤĚÁ Öǎǎǎǎǎǎǎǎǎǎǎǎǎǎǎǎǎǎǎǎǎǎǎǎǎǎǎǎǎǎ ǎǎǎǎǎǎǎǎǎǎǎǎǎǎǎǎǎǎǎǎǎǎǎǎǎǎǎǎǎǎ	P[]^ǎǎ à•ǎǎĤǎÁ		
ĤĚÁ Ø[ǎǎǎǎǎǎǎǎǎǎǎǎǎǎǎǎǎǎǎǎǎǎǎǎ	P[]^Á		
ĤĚÁ U@!Á}~•~ ǎǎǎ } ǎǎǎ }•Á	P[]^Á		





Á

'BGD97 H-CB' ±9 A'	C6 G9 F J 5 H-CBG' 85 H5'	D<CHC'	7 CAA9 BHG/ 'CH<9F'85 H5'
+ "9A9F; 9B7 MGD=@K 5M# CI H@HGHFI 7HI F9Á	Á	Á	Á
İ ÈÁ Û' æ^& } áää } Á	P[Á] q , æ Á Á' d^ó • d' &c' ^ Á çá o Á	Á	Á
İ ÈÁ Ûa } • Á - Á! [• q } Á	Á	Á	Á
İ ÈÁ Ûa } • Á - Á [ç^ { ^ } ó Ç^ { { æq } DÁ	Á	Á	Á
İ ÈÁ Ö: æ& • Á	Á	Á	Á
İ ÈÁ Û^ ç^ { ^ } ó	Á	Á	Á
İ ÈÁ Û: ^ • ^ } & ^ Á - Á à: à: Á Á à & æ^ Á	Á	Á	Á
İ ÈÁ Ö • ^ Á ^ & @ } á { Á [] ^! æq } æÁ	Á	Á	Á
İ ÈÁ Û [] ^ Á! [ç & ç } Á	Á	Á	Á
İ ÈÁ Q • çæqç Á - Á çá Á [] ^ • Á	Á	Á	Á
İ ÈÁ U c @: Á } • ^ æ^& } áää } • Á	Á	Á	Á
, "BGHFI A9BH5 H-CBÁ	Á	Á	Á
İ ÈÁ Ûa: [{ ^ ç: • Á	P[Á	Á	Á
İ ÈÁ Û^ ç^ { ^ } ó & • Á	P[Á	Á	Á
İ ÈÁ V @: { æ q } • Á	ÿ^ • Á	Á	Û^ & ç } Á ÈÁ - Á @ Á [] : ó^ • & ç^ • Á @ Á c @: { æ^& } áää } ÈÁ
İ ÈÁ Û^ ç^ { ^ } ó [] { ^ } ç Á	P[Á	Á	Á
İ ÈÁ Û^ ç { [*! æ @	P[Á	Á	Á
İ ÈÁ Q & q [{ ^ ç: Á	P[Á	Á	Á
İ ÈÁ Y ^ a • Á } á Á [, Á [] æ • Á	P[Á	Á	Á
İ ÈÁ Ö ææ ** ^ Ç DÁ	P[Á	Á	Á
İ ÈÁ U c @: Á	P[Á	Á	Á
- "8C7I A9BH5 H-CBÁ	Á	Á	Á
J ÈÁ U ^! æq } ÈT æ ç } æ & Á } á Á Û' ç^ q æ } & ^ Ç T U D Á æ Á	Á	Á	Á
Á J ÈÈ Á T Û Á æ Á çá o Á	ÿ^ • Á	Á	Á
Á J ÈÈ Á T Û Á æ Á ^ ^ & o Á & !! ^ } ó æ æ } áää } • Á	ÿ^ • Á	Á	Á
Á J ÈÈ Á Ö æ Á - Á ç o Á ç á q } Á	T æ & Ç Ç F Í Á	Á	Á
J ÈÁ Ö { ^! * ^ } & Á ^ } æ^ á } ^ • • Á Û æ Á Ç Ö Ú DÁ	Á	Á	Á



5 DD9 B8 ± '5 &
F97 CF8 'C: '8 5 A 'BGD97 H-CB''

Á

'BGD97 H-CB' ±H9 A'	C6 G9 F J 5 H-CBG' 8 5 H5'	D<CHC'	7 CAA9 BHG/ 'CH<9 F'8 5 H5'
Á JÈÈFÀÖÜÁçã º Á	ÿ^•Á	Á	Q& `á^áÁ ä@ Á@ÁUT ÙÁä áÀÖÜÁ
Á JÈÈFÀÖÜÁ^~^&º Á& !!^} óÁ & } äää }•Á	ÿ^•Á	Á	Á
Á JÈÈFÀÖæ^Á-Áæ óÁçãä }Á	CE * ~ •óGÉFÍ Á	Á	Á

%\$"BCH9 G'

Á

'bgdYWcfDj'G][bUhi fY	Á	8 UH.'	Ù^] ç{ à^!ÁÉGÉFÍ Á
------------------------	---	--------	--------------------

Á

}K&ææGÉFÍ dHá] [bFÍ Í GFI FÁæ (Á^ [ç&@q •) ÁGÉFÍ Á ^æä [, àæj \ d Á] ^] ææää } Á (Áá^áq^!æä] • äí [&ÁFÍ | JÁGÉFÍ Á^ [ç&@ ææÁq •] ^&ç] d^çÁÉH^æj] ^) äæ^•æj] ^) ää^æ^ÁÉá^, ææ^jã * Á
ää^•æçÁ [^ ç&@æj] Áä^æçÁ [^ ç&@æj] Áä^Áq •] ^&ç } ÁGÉFÍ ä [&çÁ

Á

Á

Á

Á

Á

Á

Á

Á

Á

Á

Á

Á





Ú@q *!æj @0EÁÚ[~c00æj] ÁÖá^ÁÁ

8 UHÁÚ] c{ à^!ÁÁEÖFÍ Á **Dl ch<'Bi a VYf**ÁGÍ Á

8 YgWldhcbÁÖ [{ Á@Á [~c00æ d ^) dÁ [[\ä * Á [~c00æ@Á] •d^æ Á [] ^Áæ áÁ@Á@!{ ä d | • Á • d { ^) cæj } Á
•^E] È



Ú@q *!æj @0EÁÚ[~c00æj] ÁÖá^ÁÁ

8 UHÁÚ] c{ à^!ÁÁEÖFÍ Á **Dl ch<'Bi a VYf**ÁFÁ

8 YgWldhcbÁÖ [{ Á@Á [~c00æ d ^) dÁ [[\ä * Á [~c00æ@Á] •d^æ Á [] ^Áæ áÁ@!{ ä d | • Á • d { ^) cæj } Á^E
~] È



Á

Ú@d *!aǎ @0E#ÁÚ[~c@0ǎǎ] ÁÖa^Á

8 UH1ÁÚ] c{ à^!ÁÍǎǎǎí Á

D\ chc 'Bi a VYf1Áǎí Á

8 YqW]dhcb1Á [{ Á@Á[~c@ǎǎǎǎ d ^} dǎ [\ǎ * Á [!c@ǎǎǎǎ & !^• dǎ



Á

Ú@d *!aǎ @0E#ÁÚ[~c@0ǎǎǎ] ÁÖa^Á

8 UH1ÁÚ] c{ à^!ÁÍǎǎǎí Á

D\ chc 'Bi a VYf1Áǎí Á

8 YqW]dhcb1Á [{ Á@Á[!c@ǎǎǎǎ d ^} dǎ [\ǎ * Á [~c@ǎǎǎǎ & !^• dǎ



APPENDIX A3

Bay-Goose Dike Photographic Log and Record of Inspection



5 DD9 B8 4 '5' '
65M; CCG9 '8 29 'D<CHC; F5 D<7 'C; ''



Á
Á
Á
Á
Á
Á
Á
Á
Á
Á
Á

Ú@q *!æ @EH Áes Á[] ^ Áá ^Á

8 UYKÁ] c{ à^! ÁGÁEFÍ Á D\ chc 'Bi a VYKÁ G FÁ

8 YqW] dhjcb Á [{ Áæ] : [cā æ ^ ÁÚca ÁEH ÉÁ } Á@ & ^ • dÁ [\ ā * Á] : [c@ æ ÁÁ@ Ááæ Á& ^ • Áæ áÁ [,] • d^æ Á
• [] ^Á



Á

Ú@q *!æ @EH Áes Á[] ^ Áá ^Á

8 UYKÁ] c{ à^! ÁGÁEFÍ Á D\ chc 'Bi a VYKÁ G ÉÁ

8 YqW] dhjcb Á [{ Áæ] : [cā æ ^ ÁÚca ÁEH ÉÁ [\ ā * Á] : [c@ ^ • ÁÁ@ Á] : [c@ ^ Á] æ ^ Á& @æ } ^ | ÉÁ



5 DD9 B8 4 ' 5 ' '
6 5 M; CCG9 ' 8 2 9 ' D < C H C; F 5 D < 7 ' @; ''



Á
Á
Á
Á
Á
Á
Á
Á
Á
Á
Á
Á

Ú@q *!æ @EÉÁÖs Á[] • ^ Á a ^ Á

8 UHÁ^] c{ à^! Á G Á C E F Í Á D\ chc ' Bi a Vyf Á G i Á

8 YqW] dhjcb Á[] { Á ca Á H E Í E E Á[] [\ a * Á ^ • Á a @ Á[] , } • d ^ æ Á []] ^ É Á



Á

Ú@q *!æ @EÉÁÖs Á[] • ^ Á a ^ Á

8 UHÁ^] c{ à^! Á G Á C E F Í Á D\ chc ' Bi a Vyf Á G i Á

8 YqW] dhjcb Á[] { Á ca Á H E Í E E Á[] [\ a * Á ^ • Á a @ Á[] , } • d ^ æ Á []] ^ É Á





5 DD9 B8 4 '5' '
65M; CCG9 '8 29 'D<CHC; F5 D<7 '@; ''



Á
Á
Á
Á
Á
Á
Á
Á
Á
Á
Á

Ú@q *!æ @CHÉFÁÓé Á[]•^ÁÁ^Á

8 UYKÁU] c{ à^!ÁGÁÉFÍ Á D\ chc 'Bi a VYfKÁ HÁÁ

8 YqW]dhcbKÁ [{ Áæ]!| cā æ^ ÁcáÁÉÍ ì €Á [\ā * Á [:@ÁÁ@ Á^• cā áÁ@Á]•d^æ Á []^ÉÁ



Á

Ú@q *!æ @CHÉGÁÓé Á[]•^ÁÁ^Á

8 UYKÁU] c{ à^!ÁGÁÉFÍ Á D\ chc 'Bi a VYfKÁ I Á

8 YqW]dhcbKÁ [{ Áæ]!| cā æ^ ÁcáÁÉÍ ì €Á } Á@ Á^• €Á [\ā * Á [:@ÁÁ@ Á[,]•d^æ Á []^Áæ áÁ^ÉÁ

Á



5 DD9 B8 ± '5' '
65M; CCG9 '8 ± 9 'D<CHC; F5 D<7 'C; ''



Á
Á
Á
Á
Á
Á
Á
Á
Á
Á

Ú@q *!æ @ŒĒĪ Áœ ÁŒ[·^ÁŒá^Á

8 UYKÁ^] c\ à^!FGŒĒĪ Á

D\ chc 'Bi a VYKÁĠ Ī Á

8 YqW]dhjcbÁŒ[{ Áæ]!| cā æ^ ÁŒá FĒFĒĒĪ [\ā * Á!|cŒá@ Á^•cā āÁ]•d^æ Á[]^ĒÁ



Á

Ú@q *!æ @ŒĒĪ Áœ ÁŒ[·^ÁŒá^Á

8 UYKÁ^] c\ à^!FGŒĒĪ Á

D\ chc 'Bi a VYKÁĠ Ī Á

8 YqW]dhjcbÁŒ[{ Áæ]!| cā æ^ ÁŒá FĒĒĒĒĪ } ÁŒá Á^•ĒĪ [\ā * Á!|cŒá@ Á[,]•d^æ Á[]^ĒÁ āÁĪ ^ĒÁ



5 DD9 B8 4 '5' '
65 M; CCG9 '8 2 9 'D<CHC; F5 D<7 'C; ''



Á
Á
Á
Á
Á
Á
Á
Á
Á
Á

Ú@q *!aę @EHÍ Áes ÁO[]^ÁÖa^Á

8 UNYÁU] c{ à^!Á FĞĖFÍ Á D\ chc`Bi a VYfKĠ JÁÁ

8 YqWldhcbkQ[{ Áę]!| cā æ^|` ÁÜcaĤ FÉĖ ĖÁ } Ác@ Á&!^• dĀ[[\ā * Á [~ c@ ^• Áes@ Á [] aĀ -Ā æ^! ÁesÁ^} dāĀ
Ôcā } ^!Á^^} æ^ ÁesÁÜcaĤ FÉFÍ í ĚÁ

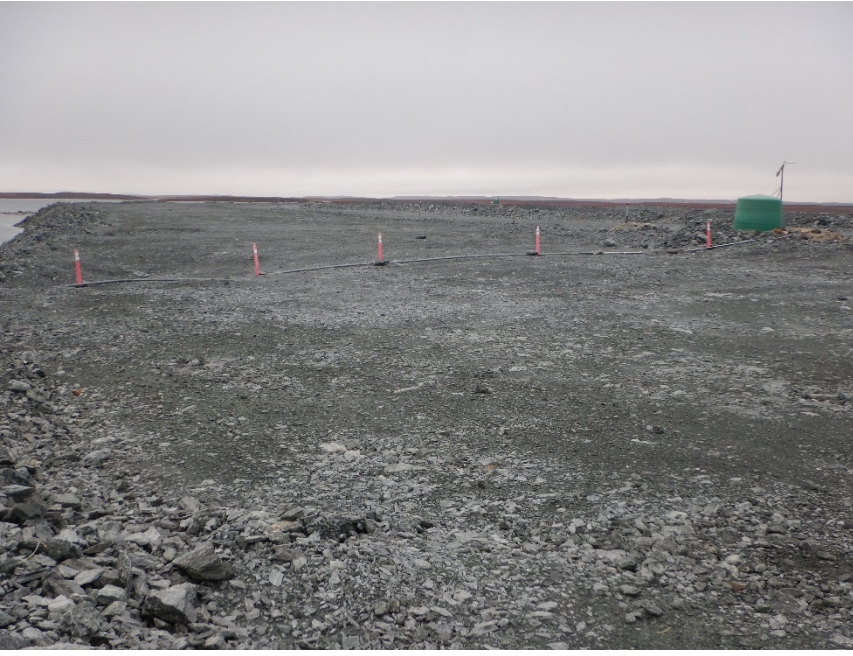

Ú@q *!aę @EHÍ Áes ÁO[]^ÁÖa^Á

8 UNYÁU] c{ à^!Á FĞĖFÍ Á D\ chc`Bi a VYfKĠ Ĩ Á

8 YqWldhcbkQ[{ Áę]!| cā æ^|` ÁÜcaĤ FÉFĖĚĀ [\ā * Á [~ c@ ^• Áes@ Á&!^• dĀ





5 DD9 B8 4 '5' '
65 M; CCG9 '8 2 9 'D<CHC; F5 D<7 '@; ''



Á
Á
Á
Á
Á
Á
Á
Á
Á
Á
Á

Ú@q *!æ @ÜHÉH Áæ Ö[] •^Öä^Á

8 UHÁ^] c\ à\!Á GÖEÍ Á D\ ch'Bi a VYÍGÍ FÁ

8 YqW]dhcbÁ[] { Á} | | çä æ^ ÁcÄ FÉG ÉÁ[] \ä * Á[] !@æ Áæ@Á[] &^•dÄ



Á

Ú@q *!æ @ÜHÉH Áæ Ö[] •^Öä^Á

8 UHÁ^] c\ à\!Á GÖEÍ Á D\ ch'Bi a VYÍGÍ JÁ

8 YqW]dhcbÁ[] { Á} | | çä æ^ ÁcÄ FÉJ ÉÁ[] \ä * Á[] !@æ Áæ@Á[] , }•d^æ Á^ Á} áÁ[]]^É



5 DD9 B8 ± '5' '
65 M; CCG9 '8 ± 9 'D<CHC; F5 D<7 ' @; ''



Á
Á
Á
Á
Á
Á
Á
Á
Á
Á
Á

Ú@q *!æ @EHÉ Áóé ÁÖ [] ^ ÁÖá ^ Á

8 UHÁ] c { à ^ / Á GÖ E F Í Á D\ chc 'Bi a VYÍ Á G Í Á

8 YqW] dhjcb ÁÖ [{ Áæ] : [cā æ ^ Á cā FÉ I J E Á [[\ ā * Á ^ • ó Á , æ á Á Ö æ } ^ | Á É Á



Á
Á
Á
Á
Á
Á
Á
Á
Á
Á
Á

Ú@q *!æ @EHÉ Áóé ÁÖ [] ^ ÁÖá ^ Á

8 UHÁ] c { à ^ / Á GÖ E F Í Á D\ chc 'Bi a VYÍ Á G Í Á

8 YqW] dhjcb ÁÖ [{ Áæ] : [cā æ ^ Á cā FÉ I G É Á [[\ ā * Á ^ • ó Á @ Á ! • ó Á æ á Á @ Á] • d ^ æ Á [] ^ É Á



5 DD9 B8 4 '5' '
65 M; CCG9 '8 29 'D<CHC; F5 D<7 '@; ''



Á
Á
Á
Á
Á
Á
Á
Á
Á
Á
Á

Ú@q *!aę @HEİ Áœ Å[]•^Äá^Á

8 UNKÁ] c{ à^!ÁGÄCFÍ Á D\ chc'Bi a VYfKÍ í Á

8 YqW]dhcbÁ [{ Á}]! cā æ^ ÁcÄFÉÍ í EÄ [\q * Á [!c@ æ óá@ Á^• ó} áÁ@ Á] •d^æ Á [] ^EÄ



Á

Ú@q *!aę @HEİ Áœ Å[]•^Äá^Á

8 UNKÁ] c{ à^!ÁGÄCFÍ Á D\ chc'Bi a VYfKÍ í Á

8 YqW]dhcbÁ [{ Á}]! cā æ^ ÁcÄFÉÍ í EÄ [\q * Á [!c@ æ óá@ Á^• ó} áÁ@ Á] •d^æ Á [] ^EÄ



5 DD9 B8 ± '5' '
65 M; CCG9 '8 ± 9 'D<CHC; F5 D<7 'C; ''



Á
Á
Á
Á
Á
Á
Á
Á
Á
Á
Á

Ú@q *!aę @CHÉJÁÖé ÁÖ[[•^ÁÖá^Á

8 UHÁ^] c\ à^!ÁGÁÖFÍ Á D\ chc 'Bi a VYfKÍG | Á

8 YqWldhcbÁÖ[[{ Áę }| cā æ^ ÁÜcāFÉÍ | É[[\ā * Áæ áÁ@Á^•Á} d^|ā ^É



Á

Ú@q *!aę @CHÉJÁÖé ÁÖ[[•^ÁÖá^Á

8 UHÁ^] c\ à^!ÁGÁÖFÍ Á D\ chc 'Bi a VYfKÍG GÁ

8 YqWldhcbÁÖ[[{ Áę }| cā æ^ ÁÜcāFÉÍ | É[[\ā * Á[!@ ^•ÁÁ@Á^•Á} áÁ@Á]•d^æ Á[[^É



5 DD9 B8 4 '5' '
65 M; CCG9 '8 29 'D<CHC; F5 D<7 'C; ''



Á
Á
Á
Á
Á
Á
Á
Á
Á
Á

Ú@q *!aæ @EHFÁÖe ÁÖ[[•^Áá^Á

8 UHYÁU] e{ à^!ÁGÁÖEÍ Á D\ chc'Bi a VYfÁGÍ HÁ

8 YgW|dhcbÁÖ[[{ Áæ]!| cā æ^ ÁcáÁFÉÍ | €É[[\ā *Á[~@æ áÁ@Á] •d^æ Á[[]^ÉÁ



Á
Á
Á
Á
Á
Á
Á
Á
Á
Á
Á
Á
Á
Á
Á
Á

Ú@q *!aæ @EHFÁÖe ÁÖ[[•^Áá^Á

8 UHYÁU] e{ à^!ÁGÁÖEÍ Á D\ chc'Bi a VYfÁGÍ FÁÁ

8 YgW|dhcbÁÖ[[{ Á@&^•ÁÁá]!| cā æ^ ÁcáÁFÉÍ | €É[[\ā *Á[~@æ áÁ[] •d^æ Á[, ááÁÖ@ }^ÁÉÁ



5 DD9 B8 4 '5' '
65M; CCG9 '8 29 'D<CHC; F5D<7 'C; ''



Á
Á
Á
Á
Á
Á
Á
Á
Á
Á

Ú@q *!aę @EHHÁÓe ÁO[[•^Áa^Á

8 UHYÁU] c{ à^!ÁGÁEFÍ Á D\ chc'Bi a VYfKÍG ÉÁ

8 YgW]dhcbKÁO[{ Á@Á^•ÁaÁ}]| cā ae^ ÁcaÁFÉÍ ĩ ĒÁ[[\ā * Á[:@Á[, }•d^aę Áa@Á ae^ Á[]]áÁÁcaÁ
HFÉÍ ĩ ĒÁ



Á
Á
Á
Á
Á
Á
Á
Á
Á
Á

Ú@q *!aę @EHHÁÓe ÁO[[•^Áa^Á

8 UHYÁU] c{ à^!ÁGÁEFÍ Á D\ chc'Bi a VYfKÍG ĩ Á

8 YgW]dhcbKÁO[{ Á}]| cā ae^ ÁcaÁFÉÍ ĩ ĒÁ[[\ā * Á[:@Á^•Áa@Á^•Áa]•d^aę Á[]]^Ē



5 DD9 B8 4 '5' '
65 M; CCG9 '8 29 'D<CHC; F5 D<7 '@; ''



Á
Á
Á
Á
Á
Á
Á
Á
Á
Á
Á

Ú@q *!aǰ @EHÍ Áes ÁO [.^ Áä ^Á

8 UHÁ] c\ à\! ÁGÁEFÍ Á D\ chc 'Bi a VYfÁG JÁÁ

8 YqW]dhjcbÁO [{ Áǰ]! cǎ æ ^ Ácǎ FÉÍ ĩ EFÁ [\ ǰ * Á [~ c@ æ cǎ Á @ & ^ Á • d^ǰ Á [] ^ÉÁ



Á
Á
Á
Á
Á
Á
Á
Á
Á
Á
Á

Ú@q *!aǰ @EHÍ Áes ÁO [.^ Áä ^Á

8 UHÁ] c\ à\! ÁGÁEFÍ Á D\ chc 'Bi a VYfÁG JÁÁ

8 YqW]dhjcbÁO [{ Áǰ]! cǎ æ ^ Ácǎ FÉJ EFÁ [\ ǰ * Á [~ c@ æ cǎ Á @ & ^ Á • d



5 DD9 B8 4 '5' '
65 M; CCG9 '8 29 'D<CHC; F5 D<7 'C; ''



Á
Á
Á
Á
Á
Á
Á
Á
Á
Á
Á

Ú@q *!aę @EHİ Áes ÁÖ[[. ^Öä ^Á

8 UHYÁU] c{ à^! ÁGÖEFÍ Á D\ chc 'Bi a VYfKĞ I Á

8 YqW]dhcbKÖ [{ Áę]!| cā æ^ Ácä FÉJGEÁ [\ā * Á [!|c@ ^• óä@ Á! ^• cÄ



Á
Á
Á
Á
Á
Á
Á
Á
Á
Á
Á

Ú@q *!aę @EHİ Áes ÁÖ[[. ^Öä ^Á

8 UHYÁU] c{ à^! ÁGÖEFÍ Á D\ chc 'Bi a VYfKĞ I Á

8 YqW]dhcbKÖ [{ Áę]!| cā æ^ Ácä FÉJGEÁ } Á@ Á! ^• cÄ [\ā * Á [~ c@ æ óä@ Á! [,) • d^ę Á [] ^Ä



5 DD9 B8 4 ' 5 ' '
65 M; CCG9 '8 2 9 'D<CHC; F5 D<7 ' @; ''



Á
Á
Á
Á
Á
Á
Á
Á
Á
Á
Á

U@d *!a@ @CHÉU/Óé/Ó/[. ^/Óá^/Á

8 UH/KÚ] c{ à^/Á FÓÉFÍ Á D\ chc 'Bi a VYf/KG i ÁÁ

8 YqW/dhcb/ÁÓ [{ Áa [^ ÁÚcaÁ FÉJGEÁ } Á@ Á&^ dÁ [\ a * Á [!@ ^ . Á , áá Á @ } ^ / Á Á [] á [a * Á caá } ÉÁ



Á
Á
Á
Á
Á
Á
Á
Á
Á
Á
Á

U@d *!a@ @CHÉU/Óé/Ó/[. ^/Óá^/Á

8 UH/KÚ] c{ à^/Á FÓÉFÍ Á D\ chc 'Bi a VYf/KG HÁÁ

8 YqW/dhcb/ÁÓ [{ Áa] [cá ae ^ ÁÚcaÁ GE-E-ÉÁ [\ a * Á [^ @ ae Á@ Á&^ dÁ



5 DD9B8 4 '5' '
65M; CCG9'8 2'9'D<CHC; F5D<7'@; ''



Á
Á
Á
Á
Á
Á
Á
Á
Á
Á

Ú@d *!aę @ŪHĪ Āœ ĀŪ[. ^Āā^Ā

8 UHĪĀ] c{ à^!ĀGĀŪĪ Ā D\ ch'Bi a VYĪĀĪ Ā

8 YqW]dhcbĀŪ[{ Āaę]!| cā æ^ ĀŪœĀHGĒĒĒ ĀG[~ cĀœ ã ċ ^} dĀ[[\ ĩ * Ā^ œ cĀœĀc@Ā&!^• dĀZ[} ^Ā[-Ā@ @Ā
{ æ } ĩ à^Ā^ċ^ { ^} œĀ Ā@Ā | dę œĀĀœĀ ĒV@Ā } • ĩ } &! œĀ • Ā^^ { Ā[Ā[] * ^! ĀœĀ^ĒĀ



Á
Á
Á
Á
Á
Á
Á
Á
Á
Á

Ú@d *!aę @ŪHĪ Āœ ĀŪ[. ^Āā^Ā

8 UHĪĀ] c{ à^!ĀGĀŪĪ Ā D\ ch'Bi a VYĪĀĪ Ā

8 YqW]dhcbĀŪ[{ Āaę]!| cā æ^ ĀŪœĀHGĒĒĒ ĀG[~ cĀœ ã ċ ^} dĀ[[\ ĩ * Ā^ œ cĀœĀc@Ā&!^• dĀZ[} ^Ā[-Ā@ @Ā
{ æ } ĩ à^Ā^ċ^ { ^} œĀ Ā@Ā | dę œĀĀœĀ ĒV@Ā } • ĩ } &! œĀ • Ā^^ { Ā[Ā[] * ^! ĀœĀ^ĒĀ

Á





5 DD9 B8 4 ' 5 ' '
6 5 M; CCG9 ' 8 2 9 ' D < C H C; F 5 D < 7 ' @; ''



Á
Á
Á
Á
Á
Á
Á
Á
Á
Á

Ú@q *!æ @OHÈ Ì Áæ Ö[[• ^ Öá ^ Á

8 UH K Á] c { à ^ Ì Á G Á C E F Í Á D l c h c ' B i a V Y f k G Ì € Á

8 Y q W l d h c b Á Ö [{ Á æ } | | c ä æ ^ Á Ú c ä Á F É E G È [[\ ä * Á ^ • Á æ Ö [[• ^ Á Ú ä Á



Á

Ú@q *!æ @OHÈ Ì Áæ Ö[[• ^ Öá ^ Á

8 UH K Á] c { à ^ Ì Á G Á C E F Í Á D l c h c ' B i a V Y f k G Ì F Á

8 Y q W l d h c b Á Ö [{ Á æ } | | c ä æ ^ Á Ú c ä Á F É E G È [[\ ä * Á ^ • Á æ Ö [[• ^ Á Ú ä Á

Á

Horizontal text at the bottom of the page, likely a disclaimer or legal notice.





APPENDIX A4

Vault Dike Photographic Log and Record of Inspection



5 DD9 B8 ± '5 (' F97 CF8 'C: '8 5 A 'BGD97 H-CB'

-BGD97 H-CB' ±H9 A'	C6 G9 FJ5 H-CBG' 85 H5'	D<CHC'	7 CAA9 BHG/ 'CH<9F'85 H5'
Í ÈÁ Ùà }•Á-Á: [•q}Á	P[]^Á à•^!ç^áÁ	Á	Á
Í ÈÁ Ùà }•Á-Á [ç^ ^) óÁ Çá^ {!{ æq} DÁ	P[Á	Á	Á
Í ÈÁ Ò:æ&•Á	P[]^Á à•^!ç^áÁ	Á	Á
Í ÈÁ Ù^ ^) æ^ Á! Á^ óæ^ æÁ	P[óq} æ^) óÁ	Á	Á
Í ÈÁ X^ * ^æq} Á! [, óÁ	P[]^Á à•^!ç^áÁ	Á	Á
Í ÈÁ U@!Á }•• æq} áq} •Á	P[]^Á	Á	Á
("8 CK BGHF95 A 'HC9'5 F95'	.	HEFÉHCGÁ	.
Í ÈÁ Ù^ ^) æ^ Á! { Áæ Á	P[]^Á	Á	Á
Í ÈÁ Ùà }•Á-Á: [•q}Á	P[óq} à•^!ç^áÁ	Á	Á
Í ÈÁ Ùà }•Á-Á: áæææ/ Á •^^) æ^ Á æ^ Á	P[Á	Á	Á
Í ÈÁ Öá & [!æq} Dæq} q* Á	P[Á	Á	Á
Í ÈÁ U~ ç^ óÁ] ^!æq} * Á!] à^ { ÁÁ Çáq}] æq} ^Á	P[óq}]] æq} ^Á	Á	Á
Í ÈÁ U@!Á }•• æq} áq} •Á	P[]^Á	Á	Á
) "56 I HA9 BHGÁ	Á	Á	Á
Í ÈÁ Ù^ ^) æ^ Á! æq} çæóÁ] ^Á Çæ^ ç ^) D{ áq} \ ^) DÁ	P[]^Á à•^!ç^áÁ	Á	Á
Í ÈÁ Ùà }•Á-Á: [•q}Á	P[]^Á à•^!ç^áÁ	Á	Á
Í ÈÁ Òç&•• q^ Á^ * ^æq} Á	P[Á	Á	Á
Í ÈÁ Ù! ^• ^) &^ Á- Á(á^) óÁ à~ !! [, •Á	P[]^Á à•^!ç^áÁ	Á	Á
Í ÈÁ U@!Á }•• æq} áq} •Á	P[]^Á	Á	Á
* "F9 G9 FJC=FÁ	Á	Á	Á
Í ÈÁ Ùææqæç Á- Á!] ^• Á	Ö [[áq} áq} •Á	Á	Á
Í ÈÁ Öá çq &^ Á! Á^ æ^ • óÁ] æ^ ÁÁ Çáq}] æq} ^Á	P[]^Á à•^!ç^áÁ	Á	Á
Í ÈÁ Ò• ç æ^ Á- Á] æ^ Á! [^ ÁÁ Çáq}] æq} ^Á	P[óq}]] æq} ^Á	Á	Á
Í ÈÁ Ø [æq} * Á^ à! áÁ	P[]^Á à•^!ç^áÁ	Á	Á
Í ÈÁ U@!Á }•• æq} áq} •Á	P[]^Á	Á	Á
+ "9A9F; 9B7 MGD=@@K 5M# CI H@H'GHFI 7HI F9Á	P[Á] q, æ^ Á! Á~ ç^ óÁ •d~ &c! ^ Á çá • ÉÁ] ^ Á á^, æ^ áq} * Á~ {] ÉÁ	Á	Á
Í ÈÁ Ù~ ! æ^ Á! } áq} Á	Á	Á	Á





5 DD9 B8 ± '5 ('
J5I @'8 ±9 'D<CHC; F5 D<7 'C; '



Ú@d *!æ @CE EÆæ |oÖa^Á

8 UHkU] c{ à!iÆ GÖE FÍ Á

D\ chc 'Bi a VYf kGJÁ

8 YqW]dHcbkÖ^ ^!æ a, Á -Á@ Áä^Á; [{ Á@ Áæ öæ' d ^} dÄ [\ä * Á [|o@ Ä æ | Áæ^Á } Á@ Áä @Á ä^Á -Á@ Á
] æc ' ^ Áæ äÁæ |oÖa^Á } Á@ Á -ö^ Ä



Ú@d *!æ @CE EÆæ |oÖa^Ä

8 UHkU] c{ à!iÆ GÖE FÍ Á

D\ chc 'Bi a VYf kEÄ

8 YqW]dHcbkÖ [{ Á@ Áæ öæ' d ^} dÄ [\ä * Á [|o@ ^ öæ@ Á^ dÄ



5 DD9 B8 ± '5 ('
J5I @'8 29'D<CHC; F5 D<7 'C; '



Á
Á
Á
Á
Á
Á
Á
Á
Á
Á
Á
Á

Ú@q *!æ @CE È Áæ |oÖa ^Á

8 UHÁU] c{ à\!Á FÖÖEFÍ Á D\ chc 'Bi a VYfÁ HEFÁ

8 YgW]dHcbÁ [{ Á[, } • d^æ È [\ ã * Á [~ c@æ dÄ



Á

Ú@q *!æ @CE È Áæ |oÖa ^Á

8 UHÁU] c{ à\!Á FÖÖEFÍ Á D\ chc 'Bi a VYfÁ HEFÁ

8 YgW]dHcbÁ [{ Á[, } • d^æ È [\ ã * Á [!c@ ^• dÄ



5 DD9 B8 ± '5 ('
J5I @'8 29'D<CHC; F5 D<7 'C; '



Á
Á
Á
Á
Á
Á
Á
Á
Á
Á
Á
Á

Ú@q *!aę @E E Áæ |oÖa^Á

8 UYKÁ] c{ à!Á FÖÖEÍ Á

D\ chc 'Bi a VYfÁEÁ

8 YgW]dHcbÁQ [{ Á@Á] ^•oáã` d ^) dÄ [\ä * Á [~ c@æ oáá@Á] ^•dÄ



Á

Ú@q *!aę @E E Áæ |oÖa^Á

8 UYKÁ] c{ à!Á FÖÖEÍ Á

D\ chc 'Bi a VYfÁEÁ

8 YgW]dHcbÁQ [{ Á@Á] •d^æ Áã^EÄ [\ä * Á [~ c@æ oáá@Á] •d^æ Á [] ^EÄ



APPENDIX B

Tailings Storage Facility



APPENDIX B1

Tailings Facility Photographic Log



5 DD9 B8 ± '6 %
HG: 'D<CHC; F5 D<7 ' @; '



Ú@q *!aq @ÓFÉÁvaaj *•Ádq !æ^ÁD&aj Á

8 UHYÁ] c{ à^!ÁÍ ÉGÉÍ Á **D\ chc 'Bi a VYfÍÁ** I Á

8 YgW]dhcbÁQ [{ ÁUaaá^ÁOaá ÁFAQa } ! [cã æ^ ÁUcaáÉÉÍ ÉDÍ [\ a * Á [!c@æ áæÁ@ Á [!c@Á^ Ácaaj * Á [] áÉÁ
Oá^~ æ^ Ácaaj * Á^æ&Oæ aaj • ÁÜÖFÁ



Ú@q *!aq @ÓFÉÁvaaj *•Ádq !æ^ÁD&aj Á

8 UHYÁ] c{ à^!ÁÍ ÉGÉÍ Á **D\ chc 'Bi a VYfÍÁ** I Á

8 YgW]dhcbÁQ [{ ÁUaaá^ÁOaá ÁFAQa } ! [cã æ^ ÁUcaáÉÉÍ ÉDÍ [\ a * Á [!c@æ áæÁ@ Á [!c@Á^ Ácaaj * Á [] áÉÁ
Oá^~ æ^ Ácaaj * Á^æ&Oæ aaj • ÁÜÖFÁ



5 DD9 B8 ± '6 %
HG: 'D<CHC; F5 D<7 '©; '



Á

Ú@q *!æ @ÓFÈ Ávaæ *•Áq !æ ^Áæææ Á

8 UHYÁ] c{ à^!ÁI ÉGEFÍ Á D\ chc 'Bi a VYfÁi JÁ

8 YgW]dHcbkQ [{ Áæá|^Áæ ÁG [\á * Á [!@æ Áæ@ Á [!@Ó^||É



Á

Ú@q *!æ @ÓFÈ Ávaæ *•Áq !æ ^Áæææ Á

8 UHYÁ] c{ à^!ÁI ÉGEFÍ Á D\ chc 'Bi a VYfÁi JÁ

8 YgW]dHcbkQ [{ Áæá|^Áæ ÁG [\á * Á [!@æ Áæ@ Á [!@Ó^||É



5 DD9 B8 ± '6 %
HG: 'D<CHC; F5 D<7 ' @; '



Ú@q *iaq @ÓFÉ Ávaq *•ÁÚq iæ^ÁDaaq' Á

8 UHYÁÚ] c{ à!FI ÉÓEFÍ Á **Dl chc'Bi a VYfKÁUÍ Á**

8 YgWJdhcbkÁQ[{ Áúaa|^ÁÓaq ÁG[[\q *Áædq, aáÁÚq |{ , æ!ÁÖa^Áa@Á[|cÁ^||É



Ú@q *iaq @ÓFÉ Ávaq *•ÁÚq iæ^ÁDaaq' Á

8 UHYÁÚ] c{ à!FI ÉÓEFÍ Á **Dl chc'Bi a VYfKÁ GÍ Á**

8 YgWJdhcbkÁQ[{ Áaq]| cā æ!^ÁÚcaZFÉHÍ Í Á} ÁÚq |{ , æ!ÁÖa^Á[[\q *Á, ^•cÁÖa^~ æ!Ácaq *•Áa^æ&@
æ aq •ÁÚq |{ , æ!ÁÖa^É

Á
Á
Á
Á
Á
Á
Á
Á
Á
Á
Á
Á
Á
Á
Á





5 DD9 B8 ± '6 %
HG: 'D<CHC; F5 D<7 ' @; '



Á
Á
Á
Á
Á
Á
Á
Á
Á
Á
Á

Ú@q *!æj @ÓFÈ Ávæj *•ÁÚq !æ^Ávæj Á

8 UYKÁ] c{ à!ÁFI ÉGEFÍ Á **D\ chc 'Bi a VYfÍÁ G Á**

8 YgWIdhcbÁÚç!ça, Á -Á@Á[!@Ó^||Á[\q * Á ^•óÁ[{ ÁÚq !{ , æ!ÁÖä^ÁÚç!çáFFÉFÉÉDÁ!^•^} &^Á -Á @q, Á , æ!Á[] äq * Áæ äq •óÁ[!ç] Á ÁÚq !{ , æ!ÁÖä^Á



Á

Ú@q *!æj @ÓFÈ Ávæj *•ÁÚq !æ^Ávæj Á

8 UYKÁ] c{ à!ÁFI ÉGEFÍ Á **D\ chc 'Bi a VYfÍÁ Í Á**

8 YgWIdhcbÁÚ[{ Á@ÁÜÜÖÁ[\q * Á[~ @ÁÜÜÖFÁÁ@Á[!@Ó^||Áq áÁ[~ @Ó^||ÉXa, Á -Á@ÁGEFÍ Á[!@Ó^||Á &q] q * ÉÁ





5 DD9 B8 ± '6 %
HG: 'D<CHC; F5 D<7 '©; '



Á
Á
Á
Á
Á
Á
Á
Á
Á
Á
Á
Á

Ú@q *!æ @ÓFÈÁVæå *•ÁÚq !æ^ÁDæåæ: Á

8 UYKÁ] c{ à^!ÁÍ ÉGÉÍ Á **Dl chc 'Bi a VYfÁÍ** í Á

8 YqW]dhcbÁ [{ Á@ÁÜÜÓÁ [[\] á * Á ^•ÁæÁÜÓFÁæ) áÁ@Á [!@Ó^||ÁÍ, æáÁÜæáá^ÁÖæ ÁGÁKa, Á Á@ÁGÉÍ Á P [!@Ó^||Áæ] á * ÉÁ



Ú@q *!æ @ÓFÈÁVæå *•ÁÚq !æ^ÁDæåæ: Á

8 UYKÁ] c{ à^!ÁÍ ÉGÉÍ Á **Dl chc 'Bi a VYfÁÍ** í Á

8 YqW]dhcbÁ [{ Á@ÁÜÜÓÁ [[\] á * Á [~ @ÁæÁÜÓFÁæ) áÁ@Á [!@Ó^||ÉKa, Á Á@ÁGÉÍ Á P [!@Ó^||Áæ] á * ÉÁ



5 DD9 B8 ± `6 %
HG: `D<CHC; F5 D<7 `@; `



Á
Á
Á
Á
Á
Á
Á
Á
Á
Á
Á
Á

Ú@q *!æ @ÓFÈHÁvæq *•ÁÚq !æ^Áæ&æc`Á

8 UHÁÚ] c{ à^!ÁÍ É@FÍ Á **Dl chc`Bi a VyfÍÁ** ÉÁ

8 YqW]dhcbÁ [{ Á@ÁÜÜ@Á [\q * Á [~c@ ^•ÁæÜÜ@Á) áÁ@Á [!c@Á^||ÉÁ, Á -Á@Á@FÍ Áæ] q * ÉÁ



Á
Á
Á
Á
Á
Á
Á
Á
Á
Á
Á
Á
Á
Á

Ú@q *!æ @ÓFÈI Ávæq *•ÁÚq !æ^Áæ&æc`Á

8 UHÁÚ] c{ à^!ÁÍ É@FÍ Á **Dl chc`Bi a VyfÍÁ** FÁ

8 YqW]dhcbÁ [{ Á@ÁÜÜ@Á [\q * Á [!c@ ^•ÁæÜÜ@Á) áÁ@Á [!c@Á^||ÉÁ, Á -Á@Á@FÍ Áæ) á@FÍ Áæ] q * ÉÁ



5 DD9 B8 ± '6 %
HG: 'D<CHC; F5 D<7 '©; '



Á
Á
Á
Á
Á
Á
Á
Á
Á
Á
Á
Á

Ú@q *!aǵ @ÓFÉÍ Ávaǵ *•ÁÚq !æ^Á@æǵá Á

8 UYKÁ] c\ à^!ÁÍ ÉGEÍ Á D\ chc 'Bi a VYfÁÍ GÁ

8 YqW]dhcbkÁ [{ Á@ÁÜÜÓÁ [\ a * Á [\ @æ ^• Á@ÁÜÜÓÁ á Á@Á [!@Ó^||ÉXa , Á -Á@ÁGEÍ Áaǵ] a * ÉÄ



Á
Á
Á
Á
Á
Á
Á
Á
Á
Á
Á
Á

Ú@q *!aǵ @ÓFÉÍ Ávaǵ *•ÁÚq !æ^Á@æǵá Á

8 UYKÁ] c\ à^!ÁÍ ÉGEÍ Á D\ chc 'Bi a VYfÁÍ FÁ

8 YqW]dhcbkÁ [{ Á@ÁÜÜÓÁ [\ a * Á [!@æ ^• Á@ÁÜÜÓÁ á Á@Á [!@Ó^||ÉXa , Á -Á@ÁGEÍ Áaǵ] a * ÉÄ





5 DD9 B8 ± '6 %
HG: 'D<CHC; F5 D<7 '©; '



Á
Á
Á
Á
Á
Á
Á
Á
Á
Á
Á

Ú@q *!æ @ÓFÉÍ Áæäq *•ÁÚq !æ^Áæ&äc' Á

8 UHÁ] c{ à^!ÁÍ ÉÓFÍ Á **Dl chc'Bi a VYfÍÁÍ** HÁ

8 YqW]dhcb Á [{ Á@ÁÚÓÁ [\ä * Á [~ c@ ^•ÁæÁÚÓÁä áÁ@Á [!c@Ó^||ÉÁa, Á -Á@ÁÓFÍ Áæäq] ä * ÉÁ



Á
Á
Á
Á
Á
Á
Á
Á
Á
Á
Á
Á

Ú@q *!æ @ÓFÉÍ Áæäq *•ÁÚq !æ^Áæ&äc' Á

8 UHÁ] c{ à^!ÁÍ ÉÓFÍ Á **Dl chc'Bi a VYfÍÁÍ** | Á

8 YqW]dhcb Á [{ Á@Á ^•c!} ÁÖä^!•ä } ÁÖ&Ö [\ä * Áæ ÁæÁ@Á [!c@Ó^||ÉÁa, Á -Á@ÁÓFÍ Áæäq] ä * ÉÁ





5 DD9 B8 ± 6 %
HG: 'D<CHC; F5 D<7 ' @; '



Á
Á
Á
Á
Á
Á
Á
Á
Á
Á
Á

Ú@q *!æj @ÓFËJÁæj *ÁÚq !æ^Áæ&æc' Á

8 UHYÁÚ] c{ à^!ÁÍ É@FÍ Á **D\ chc'Bi a VYfÁÍ** í Á

8 YqWldhcbkÁ [{ Á@Á ^c!} ÁÖá^!á } ÁÖá@ [\á *Á [~ @æ áá@ Á [:c@^||ÉKa , Á-Á@Á@FÍ Áæj] á *ÉÁ



Á
Á
Á
Á
Á
Á
Á
Á
Á
Á
Á
Á
Á
Á

Ú@q *!æj @ÓFËJÁæj *ÁÚq !æ^Áæ&æc' Á

8 UHYÁÚ] c{ à^!ÁÍ É@FÍ Á **D\ chc'Bi a VYfÁ** FJÁ

8 YqWldhcbkÁ [\á *Á [~ @æ áá@ ÁÚ [~ c@^||Áæ áá@ Á] •d^æ Á [] ^Á-ÁÚq [{ , æ^!ÁÖá^ÉÁ



5 DD9 B8 ± '6 %
HG: 'D<CHC; F5D<7'@; '



Á

Ú@q *!aę @ÓFĒGÁ/aęę *•ÁŪq !aē^ÁŌaęęĀ ĀĀ

8 UHYÁŪ] c{ à^!ÁĪ ĒŌEFĪ Á **D\ chc'Bi a VYfĪÁ** FĪ Á

8 YgWjdhcĪĪ[{ Á@Á[!c@!} Áa~ d ^} dĀ -ÁŌ^} dāŌä^Ē[\ā * Á[~ c@ae ÁaŌ^} dāŌä^Áę āÁ@ÁŪ[~ c@Ō^||ĒĀ



Á

Ú@q *!aę @ÓFĒGÁ/aęę *•ÁŪq !aē^ÁŌaęęĀ ĀĀ

8 UHYÁŪ] c{ à^!ÁĪ ĒŌEFĪ Á **D\ chc'Bi a VYfĪÁ** FĪ Á

8 YgWjdhcĪĪ[{ ÁŌ^} dāŌä^ÁĪ \ā * Á[!c@^ ÁaŌ^ÁŪ[~ c@Ō^||ĒĪ , aē•ÁŪq !{ , aē!Ōä^ĒĀ



5 DD9 B8 ± '6 %
HG: 'D<CHC; F5 D<7 ' @; '



Ú@q *!aq @ÓFEGHÁaaq *ÁÚq !ae^Áaaqac Á

8 UYKÁ] c{ à^!ÁI ÉÓFÍ Á **Dl chc'Bi a VYfÁ** FÍ Á

8 YgW]dhcbkÁ [{ Á^} daqÁÖá^Á [\q * Á [~ c@ ^•Áaa@ÁÚ [~ c@Á||Á, aa•ÁÚaa|ÁÖaq Á ÉV@Á [&aa } Á -Á@Á
aaq *Áã &@e*^Á q^Áq d Á@ÁÚ [~ c@Á||Á Á@Áaa *! [~ } áÁ -Á@Á ac !^É



Ú@q *!aq @ÓFEGHÁaaq *ÁÚq !ae^Áaaqac Á

8 UYKÁ] c{ à^!ÁI ÉÓFÍ Á **Dl chc'Bi a VYfÁ** ÉI Á

8 YgW]dhcbkÁ [{ Á^} daqÁÖá^Á [\q * Á [!c@ ^•Áaa^} daqÁÖá^Á aa@ÁÚ [~ c@Á||Á, aa•ÁÚq !, ae^ÁÖá^É



APPENDIX B2

Saddle Dam 1 Photographic Log and Record of Inspection



5 DD9 B8 ± '6 &
F97 CF8 'C: '8 5 A 'BGD97 H-CB'

7 'Ybh' OOT Á 6 m' Yç^•ÁÓ[~ |ã] } ^Á
 Dfc 'VWh' T ^ã[, àã \ Á 8 UH.' Ú] ç{ à\!Áí ÈGEÍ Á
 @WUjcb.' Úãà| ^ÁÖæ ÁÁ FYj JYk YX.' Yç^•ÁÓ[~ |ã] } ^Á

; 9B9F5 @-B: CFA5H-CB'

8 Ua 'HndY.' Ü[& ç|Á{ àã \ { ^} ó ãöç ç\!çáÁç\!Á } Áæ^È] •d^æ Áç\!•ÈÁ^ { ^{ à\!ç^Áç \!Áç ááç Áæ ç ^Áç|Á } * Áç áÁ | [ç & ç ^ Á ç | Á

K YUH Yf '7 cbX]jcbg.' Uç\!æçÁ HYa dYfUi fY.' Í »ÔÁ

'BGD97 H-CB' ±9A'	C6 G9F J5 H-CBG' 85 H5'	D<CHC'	7CAA9BHG/ 'CH<9F'85 H5'
%'85A '7F9GH		Hì ÈÁí FÈÁí Á	
FÈÁ Ô\^•ç\!çã } Á	Fí ÈÁ Á		Ö•ç } Áí ÈÁ Á
FÈÁ Ü^•ç\! ç\!ç\!Á	Fí JÈ Á Áçã *•Á		
Ö\!^} ç\!ç\!á çáÁ	ÈÈ Á Áçã *•Á		Ö•ç } Áç Á ç\!ÈÈ Á Áçã *•Á
FÈÁ Öã çæ & \! Áçã *•Á [] áÁ ç\!ç\! çã\!Á	NHEÈÁ Á		Vãç *•Á çç\!ç\! } * ÁÜÖÁ
FÈÁ Ü\! ç\!ç\! çã ç * Á	P [] ^ Áç\! ^ Á ç\! ç\! } Á		
FÈÁ W\! ç\! ^ ç\!ç\! ç\!ç\! { ^} ó	P [] ^ Á ç\!ç\! ç\!ç\! áÁ		
FÈÁ Šç\!ç\! [ç\! { ^} ó	P [ç\!] ç\!ç\! ó		
FÈÁ Uç\!ç\! } ~ • ç\!ç\! } áçã } • Á	P [] ^ Á		
&'I DGHF95A 'G@CD9		Hì JÈÁí GÈÁí HÈÁí Á	
GÈÁ Ü [] ^ Áç\! * Á	Ç [] ÈÁ PKEÁ		Ü [& ç Á
GÈÁ Üç\! } • Á ç\!ç\! } Á	P [] ^ Á ç\!ç\! ç\!ç\! áÁ		
GÈÁ Üç\! } • Á ç\!ç\! [ç\! { ^} ó ç\!ç\! çã\!Á	P [] ^ Á ç\!ç\! ç\!ç\! áÁ		
GÈÁ Ô\!ç\! • Á	P [] ^ Á ç\!ç\! ç\!ç\! áÁ		
GÈÁ Öç\!ç\! ç\!ç\! } áçã } Á ç\!ç\! çã\!Á	QÁ [[áç\!] áçã } Á		
GÈÁ Uç\!ç\! } ~ • ç\!ç\! } áçã } • Á	P [] ^ Á		
' "8CK BGHF95A 'G@CD9		Hì ÈÁí FÈÁí ÈÁí Á	
HÈÁ Ü [] ^ Áç\! * Á	Ç [] ÈÈ PÁ Á FÈ PKEÁ çã\!Á		Ü [& ç Á
HÈÁ Üç\! } • Á ç\!ç\! } Á	P [] ^ Á ç\!ç\! ç\!ç\! áÁ		





5 DD9 B8 ± '6 &
F97 CF8 'C: '8 5 A 'BGD97 H-CB'

'BGD97 H-CB' 'H9 A'	C6 G9 FJ5 H-CBG' 85 H5'	D<CHC'	7 CAA9 BHG/ 'CH<9F'85 H5'
H ĒÁ Úā}•Ā Ā [ç^ (^) ó Ç^†!{ āā} DĀ	P[]^Ā à•^!ç^āÁ	Á	Á
H ĒÁ Ô:āā•Á	P[]^Ā à•^!ç^āÁ	Á	Á
H ĒÁ Ú^∧} āĀ Ā!Ā ^oāāāĀ	P[]^Ā à•^!ç^āÁ	Á	Á
H ĒÁ X^*^āā} Ā![, oĀ	P[]^Ā à•^!ç^āÁ	Á	Á
H ĒÁ Uo@!Ā}~•~ āā{ } āā}•Ā	P[]^Ā	Á	Á
("8 CK BGHF95 A 'HC9'5 F95'	Á	H í Ē Ā í Ā	Á
I ĒÁ Ú^∧} āĀ { Āā Ā	Wj &^!āā Ā	Á	Oāā, āāā *Ā~ { } Āā •āāāĀ ā[,]•d^āā ĒY āāĀ āĀ à•^!ç^āÁ][] āā *Ā ĀāāāāĀ
I ĒÁ Úā}•Ā Ā! [•ā} Ā	P[]^Ā à•^!ç^āÁ	Á	Á
I ĒÁ Úā}•Ā Ā! āāāā Ā •^∧} āĀ āāĀ	P[oā] āāā^Ā	Á	Á
I ĒÁ Öā & [āā} Dāā ā *Ā	P[Ā	Á	Á
I ĒÁ U~d^oĀ] ^!āā *Ā! [ā^ { Ā Ç^†!} āāā^Ā	P[oā] āāā^Ā	Á	Á
I ĒÁ Uo@!Ā}~•~ āā{ } āā}•Ā	Á	Á	Á
) "56I HA9 BHGĀ	Á	Á	Á
I ĒÁ Ú^∧} āĀ { āāā [}^Ā Ç^~ d (^) D { āā } \ (^) DĀ	P[]^Ā à•^!ç^āÁ	Á	Á
I ĒÁ Úā}•Ā Ā! [•ā} Ā	P[]^Ā à•^!ç^āÁ	Á	Á
I ĒÁ Öç&••āĀĀ^*^āā} Ā	P[Ā	Á	Á
I ĒÁ Ú!^•^} &Ā Ā! [ā^] ó ā^! [, •Ā	P[]^Ā à•^!ç^āÁ	Á	Á
I ĒÁ Uo@!Ā}~•~ āā{ } āā}•Ā	P[]^Ā	Á	Á
* "F9G9 FJC=FĀ	Á	Á	Á
I ĒÁ Úāāāā Ā Ā! []^•Ā	Úāāā^Ā	Á	Á
I ĒÁ Öāā &Ā Ā! āā•oĀ āāā	P[]^Ā à•^!ç^āÁ	Á	Á
I ĒÁ Öā āā Ā! āā [{ ^Ā Ç^†!} āāā^Ā	P[oā] āāā^Ā	Á	Á
I ĒÁ Ø [āā *ĀāāāĀ	P[]^Ā à•^!ç^āÁ	Á	Á
I ĒÁ Uo@!Ā}~•~ āā{ } āā}•Ā	P[Ā	Á	Á
+ "9A9F; 9B7 MGD=@K 5M# CI H@H'GHFI 7HI F9Ā	Á	Á	Á
I ĒÁ Ú~!āāā { } āā} Ā	P[Ā] ā, āā!Ā~d^oĀ •d~ &ç!^Āāāā [] Ā ā^, āāā *Ā~ { } Ā	Á	Á
I ĒÁ Úā}•Ā Ā! [•ā} Ā	Á	Á	Á



5 DD9 B8 ± '6 &
F97 CF8 'C: '8 5 A 'BGD97 H-CB'

'BGD97 H-CB' 'H9 A'	C6 G9 FJ5 H-CBG' 85 H5'	D<CHC'	7 CAA9 BHG/ 'CH<9F'85 H5'
İ ĖÁ Úā } • Ā Ā [ç^ { ^ } á Ç^† ! { āā } DĀ	Á	Á	Á
İ ĖÁ Ô:āā • Á	Á	Á	Á
İ ĖÁ Ú^† { ^ } á	Á	Á	Á
İ ĖÁ Ú: ^ • ^ } & Ā Ā Ā Ā Ā Ā Ā à & æ ^ Á	Á	Á	Á
İ ĖÁ Ô [• ~ † Ā Ā ^ & @ ā { Á [] ^ † āā } āĀ	Á	Á	Á
İ ĖÁ Ú [] ^ Ā ! [† & ç] Á	Á	Á	Á
İ ĖÁ Q • çāāā Ā Ā ā Ā [] ^ • Á	Á	Á	Á
İ ĖÁ U @ † Á } ~ † Ā [] āāā } • Á	Á	Á	Á
, "BGHFI A9BH5 H-CBÁ	Á	Á	Á
İ ĖÁ Úā: [{ ^ † • Á	† [Á	Á	Á
İ ĖÁ Ú^† { ^ } † Ā • Á	† [Á	Á	Á
İ ĖÁ V @ † { ā ā † • Á	Ÿ • Á	Á	Ú ^ Ā Ā & ç] Á Ė Ā Ā @ Ā Ā [] † Ā
İ ĖÁ Ú^† { ^ } † [] ~ { ^ } • Á	† [Á	Á	Ô [] • † & ç] Ā Ā ā ā * • Á @ Ā Ā † { ^ } á { [] ~ { ^ } • Ā Ā Ā Ā • çā Ā Ā } Ā ç Ā Ā Ā & ^ • Ā
İ ĖÁ Úā { [* † @ Ā	† [Á	Á	Á
İ ĖÁ Q ā ā [{ ^ † Á	† [Á	Á	Á
İ ĖÁ Y ^ ā • Ā ā Ā [, Ā [] ā † • Á	† [Á	Á	Ú † Ā @ Ā Ā ā } Ė Ā Ā Ā } ā Ā Ā [] & ç] Ā ā Ā [] ~ { [] āā Ā Ā • † { Ā Ā ā Ā
İ ĖÁ Ö āā [* * ^ † Ā	† [Á	Á	Á
İ ĖÁ U @ † Á	Á	Á	Á
- "8 C7I A9BH5 H-CBÁ	Á	Á	Á
J ĖÁ [] ^ † āā } Ė Ā ā ā † } & Ā Ā ā Ā Ú † ç ā ā } & Ā Ā Ú Ā Ú Ā Ā Ā	Á	Á	Á
Á J Ė Ė Ā Ú T Ú Ā [] ā Ā • Á	Ÿ • Á	Á	Á
Á J Ė Ė Ā Ú T Ú Ā [] ā Ā Ā & Ā Ā & † Ā } āāā } • Á	Ÿ • Á	Á	Á
Á J Ė Ė Ā Ö āā Ā Ā ā Ā Ā Ā } Á	T āā @ Ā Ā Ā	Á	Á
J Ė Á { ^ * ^ } & Ā [] ^ † āā } • Á Ú āā Ā Ā Ú Ā	Á	Á	Á
Á J Ė Ė Ā Ú Ú Ā Ā Ā • Á	Ÿ • Á	Á	Q ā Ā ā Ā ā ā Ā Ā Ā Ú T Ú Ā ā Ā Ú Ā [] ā Ā
Á J Ė Ė Ā Ú Ú Ā Ā Ā Ā Ā Ā Ā Ā & } āāā } • Á	Ÿ • Á	Á	Á
Á J Ė Ė Ā Ö āā Ā Ā ā Ā Ā Ā } Á	CE * * † Ā Ā Ā	Á	Á





5 DD9 B8 ± '6 &
F97 CF8 'C: '8 5 A 'BGD97 H-CB'

BGD97 H-CB' #H9 A'	C6 G9 FJ5 H-CBG' 8 5 H5'	D< CHC'	7 CAA9 BHG/ 'CH<9 F'8 5 H5'
--------------------	-----------------------------	---------	-----------------------------

%\$"BCH9G'."

Á

.

b9dYWcf9G[bUli fY		8 UNY.'	Ù^] 9\ à^!ÁÍ ÉCÉFÍ Á
--------------------	--	---------	----------------------

Á

)K&caCDEFÍ dHj!{ bFÍÍ CFÍ FÁe(Á^[\ 9&@9] ÁCÉFÍ Á ^æ[, a9\ d Á!^] æææ) Á -Á^|9^!æ|æ^æ[&FÍ I JÁCÉFÍ Á^[\ 9&@ ææ9] ^&ç] d^çÁEdVæj] ^) áæ^ææ] ^) áæ^Áææ -æí G^ææá/^Áææ Á FæGÉÁææá/^Áææ /Æ/9] ^&ç) ÁCÉFÍ Éá[&cÁ

Á

Á

Á

Á

Á

Á

Á

Á

Á

Á

Á

Á

Á

Á

Á

Á

Á



5 DD9 B8 ± '6 &
G588 @ '85 A '%D<CHC; F5 D<7 ' @; ''



Á

Photograph B2-1 Saddle Dam 1

8 UH **Á**] c{ à^!ÁI ÉCÉFí Á **D\ chc 'Bi a VYf** **Á** í Á

8 YqW **d** **h** **c** **b** **Á** **Q** [{ Á@Á [~ c@á d ^) d ÚcaZÉHí ÉD [[\ a * Á [! c@Á@Á [, } • d^æ Áæ&Ép [c&Á@Á^æBæ Á & } cæ ^!Á @!^Áá {] Á Á • cæ^áÉÁ



Á

Photograph B2-2 Saddle Dam 1

8 UH **Á**] c{ à^!ÁI ÉCÉFí Á **D\ chc 'Bi a VYf** **Á** í Á

8 YqW **d** **h** **c** **b** **Á** **Q** [{ ÁÚcaZÉFí ÉÁ [[\ a * Á [~ c@Á@Á [, } • d^æ Áæ&Ép [c&Á@Á^æBæ Á& } cæ ^!Á @!^Áá • ~ {] Á Á • cæ^áÉÁ



5 DD9 B8 ± '6 &
G588 @ '85 A '%D<CHC; F5 D<7 'C; "



Á

Á

Photograph B2-3 Saddle Dam 1

8 UHYÁ] c{ à^|ÁÍ ÉGFI Á D\ chc 'Bi a VYfÁi ÉÁ

8 YgW]dihcbkQ [{ Áq] | cā æ | ÁcaÉÉGGÍ ÉÍ [\ a * Á [| cā@Á^•dÁ



Á

Photograph B2-4 Saddle Dam 1

8 UHYÁ] c{ à^|ÁÍ ÉGFI Á D\ chc 'Bi a VYfÁi FÁ

8 YgW]dihcbkQ [{ Áq] | cā æ | ÁcaÉÉGGÍ ÉÍ [\ a * Á [| cā@Á^•dÁ } •d^æ Á [] ^ÉÁ



Á

Photograph B2-5 Saddle Dam 1

8 UH KÁ] c{ à^!ÁI ÉCÉÍ Á D\ chc 'Bi a VYf KÁ i | Á

8 YgW | dhcb KÁ [{ Á }] : [cā æ | 'Á cā ÉÉ í É [\ā * Á [~ cā cā @ Á] • d^æ Á [] ^ÉÁ



Á

Photograph B2-6 Saddle Dam 1

8 UH KÁ] c{ à^!ÁI ÉCÉÍ Á D\ chc 'Bi a VYf KÁ i GÁ

8 YgW | dhcb KÁ [{ Á }] : [cā æ | 'Á cā ÉÉ í É] • d^æ É [\ā * Á [~ cā cā @ Á] • d^æ Á [] ^ÉÁ ~ æ Á cā * • Á
à^æ @ Á æ ā • Á ŐÉÁ



5 DD9 B8 ± '6 &
G588 @ '85 A ' %D<CHC; F5 D<7 ' @; "



Á

Photograph B2-7 Saddle Dam 1

8 UHYÁ] c{ à^!ÁI ÉGEFÍ Á **D\ chc'Bi a VYfÁ**í HÁ

8 YgW]dHcbÁQ[{ Áq]| cā æ^| ÁcæÉÉFJÍ Á]•d^æ É[[\ā *Á [!cÁc@Á]•d^æ Á [[]^ÉCa^~ æ^Ácāq *•Á à^æ&@æ āq •ÁÜÖFÄ



Á

Photograph B2-8 Saddle Dam 1

8 UHYÁ] c{ à^!ÁI ÉGEFÍ Á **D\ chc'Bi a VYfÁ**í JÁ

8 YgW]dHcbÁQ[{ Ác@Á [~cÁcā d ^ } cÁ[[\ā *Á [!cÁc@Á]•d^æ Á [[]^ÉCa^~ æ^Ácāq *•Á à^æ&@æ āq •ÁÜÖFÄ

) Kæ&cāGEFÍ dHj]| táfí cFí FÁæ (Á^ [c&@q •) ÁGEFÍ Á ^æ[, àq \ d Á]^] ææq) Á -Á^!q^!æ^!•æ[&Fí] JÁGEFÍ Á^ [c&@ ææq •] ^&q) d^cÁcHæq] ^] àæ^•æq] ^] àæ^Ácā - àiGÁ æá^!Áæq Á FæGÉÆ æá^!Áæq ÁFÁ @ d Á^ *ÁGEFÍ Bā [&cÁ





APPENDIX B3

Saddle Dam 2 Photographic Log and Record of Inspection



5 DD9 B8 ± ' 6 ' '
G588 @ ' 85 A ' & ' D < C H C ; F 5 D < 7 ' @ ; '



Á

Photograph B3-1 Saddle Dam 2

8 UH Y Á] c { à ^ ! Á I É C E F Í Á D l c h c ' B i a V Y f Á h i Á

8 Y g W] d h c b Á [{ Á Ú a a á ^ Á Ö æ Á G Á G á } ! [c á æ ^ Á Ú c a z Á G E F F E D Á [[\ á * Á [~ c @ æ á a Á @ Á & ! ^ • c á a á Á] • d ^ æ Á
• [[] ^ Á - Á Ú a a á ^ Á Ö æ Á G Á V @ Á a a á * • Á ^ æ & Á a á a á • Á Ü Ö G á Á a a ^ ~ æ Á



Á

Photograph B3-2 Saddle Dam 2

8 UH Y Á] c { à ^ ! Á I É C E F Í Á D l c h c ' B i a V Y f Á h i Á

8 Y g W] d h c b Á [{ Á a } ! [c á æ ^ Á Ú c a z Á G E H Í E Á [[\ á * Á [~ c @ æ á a Á @ Á & ! ^ • c á a á Á] • d ^ æ Á [[] ^ Á





5 DD9 B8 ± '6' ' '
G588 @ '85A '&'D<CHC; F5D<7 'C; ' '



Á

Photograph B3-3 Saddle Dam 2

8 UHKAU] c{ à! /FI ÉCÉFI Á D\ ch' Bi a VYfKHi i Á

8 YgWJdHcbkQ [{ Áq] ; | cā æ' Ácā ÉCÉHI ÉÁ [[\ā * Á [!c@ ^• óá@ Á! ^• óá] • d^æ Á [] ^É



Á

Photograph B3-4 Saddle Dam 2

8 UHKAU] c{ à! /FI ÉCÉFI Á D\ ch' Bi a VYfKHi UGÁ

8 YgWJdHcbkQ [{ Áq] ; | cā æ' Ácā ÉCÉHI ÉÁ [, } • d^æ ÉÁ [[\ā * Á [!c@ ^• óá@ Á! [, } • d^æ Á [] ^É



APPENDIX B4

Stormwater Dike Photographic Log and Record of Inspection



5 DD9 B8 ± '6 ('
 F97 CF8 'C: '8 5 A 'BGD97 H-CB'

'BGD97 H-CB' #H9 A'	C6 G9 FJ5 H-CBG' 85 H5'	D< CHC'	7 CAA9 BHG/ 'CH<9F'85 H5'
* "F9 G9 F J C=F Á	Á	Á	Á
Ì ÈÁ Ù cæãäç Ä -Á [] ^•Á	Ù cæã ^Á	Á	Á
Ì ÈÁ Ö ä çæ & ^Ä Ä ^æ^• óÄ æ^ÄÄ (Ä/Ä) æã ^Ä	Þ [] ^Ä à• ^iç^áÁ	Á	Á
Ì ÈÁ Ò• ä æ Ä -Á æ^Ä/ { ^ÄÄ (Ä/Ä) æã ^Ä	Þ [öÄ] æã ^Á	Á	Á
Ì ÈÁ Ø [æä * Ä^ài:ä Á	Þ [] ^Ä à• ^iç^áÁ	Á	Á
Ì ÈÁ U c@:Á } ~• æÄ [] äãä } • Á	Þ [Á	Á	Á
+ "9A9F; 9B7 MGD=@@K 5M# CI H@H'GHFI 7HI F9Á	Þ [Á] ä, æ Ä Ä ~ ç^óÄ • d ~ & c ^Ä ç ä • Ä { ^ Á ä^, æ^iä * Ä { } Á	Á	Á
Ì ÈÁ Ù ~ æ Ä [] äãä } Á	Á	Á	Á
Ì ÈÁ Ù ä } • Ä -Ä [• ä } Á	Á	Á	Á
Ì ÈÁ Ù ä } • Ä -Ä [ç^ (^) óÄ (Ä^ { { æä } Ä	Á	Á	Á
Ì ÈÁ Ö :æÄ • Á	Á	Á	Á
Ì ÈÁ Ù ^ç^ (^) óÄ	Á	Á	Á
Ì ÈÁ Ù ^• ^) & ^Ä -Ä^ài:ä Ä Ä à & æ^ Á	Á	Á	Á
Ì ÈÁ Ö [• ~ ^Ä ^ & @ä ä Á [] ^ æä } æ Á	Á	Á	Á
Ì ÈÁ Ù [] ^Ä [ç & ç } Á	Á	Á	Á
Ì ÈÁ Q • cæãäç Ä -Á äÄ [] ^• Á	Á	Á	Á
Ì ÈÁ € U c@:Á } ~• æÄ [] äãä } • Á	Á	Á	Á
, "BGHFI A9BH5 H-CBÁ	Á	Á	Á
Ì ÈÁ Ù ä : [{ ^ç:• Á	ÿ^• Á	Á	Ù ^Ä Ù ^çä } Á ÈÁ
Ì ÈÁ Ù ^ç^ (^) óÄ • Á	Þ [Á	Á	Á
Ì ÈÁ V c@: { ä ç • Á	ÿ^• Á	Á	Ù ^Ä Ù ^çä } Á ÈÁ
Ì ÈÁ Ù ^ç^ (^) óÄ [] { ^) óÄ	ÿ^• Á	Á	Ù ^Ä Ù ^çä } Á ÈÁ
Ì ÈÁ Ù ä { [* ä @Ä	Þ [Á	Á	Á
Ì ÈÁ Q & ä [{ ^ç: Á	Þ [Á	Á	Á
Ì ÈÁ Y ^ä • Ä äÄ [, Ä [] ä • Á	Þ [Á	Á	Á
Ì ÈÁ Ö ää [** ^ ç Ä	Þ [Á	Á	Á
Ì ÈÁ U c@:Á	Þ [] ^Á	Á	Á





5 DD9 B8 ± '6 ('
 F97 CF8 'C: '8 5 A 'BGD97 H-CB'

'BGD97 H-CB' #H9 A'	C6 G9 FJ5 H-CBG' 85 H5'	D< CHC'	7 CAA9 BHG/ 'CH<9 F'85 H5'
- "8 C7I A9 BH5 H-CBÁ	Á	Á	Á
JÈÉÁU] ^! aã } ÈT aã } aã } & ^ Á } áÁ Ú' !ç ^ aã } & ^ ÁUT ÚDÚ } Á	Á	Á	Á
Á JÈÉÁUT ÚÁU } Á çã • Á	ÿ^•Á	Á	Á
Á JÈÉÁUT ÚÁU } Á ^-^ & Á & !!^ } aã } & } áã } • Á	ÿ^•Á	Á	Á
Á JÈÉÖæ Á Áæ Á^çã } Á	T æ & ÖEFÍ Á	Á	Á
JÈÖ (^! * ^) & ÁU! ^ } æ^á } ^•• Á Ú } Á ÖÚÚÁ	Á	Á	Á
Á JÈÉÖÚÚÁ çã • Á	ÿ^•Á	Á	Q& á^áÁ æ ÁUT ÚÁ } á ÖÚÚÁ
Á JÈÉÖÚÚÁ ^-^ & Á !!^ } Á & } áã } • Á	ÿ^•Á	Á	Á
Á JÈÉÖæ Á Áæ Á^çã } Á	CE * • ÖEFÍ Á	Á	Á

%\$ "BCH9 G'. Á

Á

'bgdYWcfÉ G] bUhi fY	8 UH.'	Ú^] } à^! Á ÖEFÍ Á
----------------------	--------	--------------------

Á

} Kæ&æ ÖEFÍ áH: [bFÍ Í GFÍ Fæ (Á^ [& @ •] ÖEFÍ Á ^æ [, áã \ d Á !^ } áã } Á - Á ^ á^ áã !^ • á [& FÍ I J ÖEFÍ Á ^ [& @ æ á •] ^ & ç] d ^ ç Á æ H } ^) áã • æ] ^) áã Á ÖEFÍ - á! Á ç ! { , æ ! Á áá^ á! Á ç ! { , æ ! Á áá^ á •] ^ & ç } ÖEFÍ È [& ç Á





5 DD9B8 ± '6 ('
GHCFA K 5H9F '8 ±9 'D<CHC; F5D<7 'C; '



Photograph B4-1 Stormwater Dike

8 UHKA] c{ à^!ÁI ÉGEÍ Á D\ chc 'Bi a VYfKÁ G Á

8 YqWldhcbKQ [{ Á@Áæ Áa` d ^ } o'FFÉFEEÁq] [cā æ ^ DÁ [\ā * Á ^ Á@Á] • d^æ Áæ ÉÜ@q [, Á æ^!Á
[] āā * Áæ ā • o' [: cā] Á - Á@Áā ^ Áq • Á@q Á É& Á ^ ^ DÁV@ Áāā * Á ^ æ & Á & } • ā ^ ! á Áā ^ ~ æ ^ É



Photograph B4-2 Stormwater Dike

8 UHKA] c{ à^!ÁI ÉGEÍ Á D\ chc 'Bi a VYfKÁ GGÁ

8 YqWldhcbKQ [{ ÁcaÉÉí í É [\ā * Áæ Á@Á] • d^æ Á [] ^ ÉCā ^ ~ æ ^ Áāā * Á ^ æ & Á





Á
Á
Á

Photograph B7-3 Stormwater Dike

8 UYKÁ] c{ à^!ÁI ÉCÉÍ Á D\ ch'Bi a VYfÁ GÁ

8 YqW]dHcbÁQ[{ ÁÚcaÉÉÍ í €Á[[\ā *Á, ^•oÁæÁ@Á]•d^æ Á•[[]^ÉÚCq[[, Á, æ^!Áææ•d][!q}Á[-Á
Ùq!{, æ^!ÁÖ^ÉV@Áæā *•Á^æ&ÖÁÁ^~ æ^É



Á

Photograph B7-4 Stormwater Dike

8 UYKÁ] c{ à^!ÁI ÉCÉÍ Á D\ ch'Bi a VYfÁ GÁ

8 YqW]dHcbÁQ[{ Áq][!q æ^!ÁÚcaÉÉÍ í Á[[\ā *ÁæoÁ@Á]•d^æ Á[[]^ÉÁ^~ æ^Áæā *•Á^æ&ÖÁ



Á

Photograph B7-5 Stormwater Dike

8 UH K Á] c { à ^ ! Á F É C F Í Á D l c h c ' B i a V Y f k Á G Í Á

8 Y q W l d h c b k Á [{ Á }] ! c á æ ^ Á c á F É H Í Á [[\ a * Á ^ • c á @ Á] • d ^ æ Á [[] ^ É C Á ^ ~ æ ^ Á c á } * • Á ^ æ @ Á



Á

Photograph B7-6 Stormwater Dike

8 UH K Á] c { à ^ ! Á F É C F Í Á D l c h c ' B i a V Y f k Á G Í Á

8 Y q W l d h c b k Á [{ Á }] ! c á æ ^ Á c á F É F Í É Á [[\ a * Á æ Á ! • ^) & ^ Á Á c | Á @ Á ^ [{ ^ { à ! æ ^ É Á



Á

Photograph B7-7 Stormwater Dike

8 UHYÁ] c{ à^!ÁÍ ÉCÉÍ Á D\ ch'Bi a VYfÁ FJÁ

8 YqW]dhcbkQ [{ Ácaí FÉÍ í ÉÁ [\ā * Áæ áÁ@ Á^ Áæ áÁ@ Á[, } • d^æ Á [] ^ÉÁ



Á

Á

Photograph B7-8 Stormwater Dike

8 UHYÁ] c{ à^!ÁÍ ÉCÉÍ Á D\ ch'Bi a VYfÁ Fí Á

8 YqW]dhcbkQ [{ Ácaí FÉÍ í ÉÁ [\ā * Á^ Áæ áÁ@ Á^ Áæ áÁ@ Á[, } • d^æ Á [] ^ÉÁ caá qā æā } Áā cd^• Áā Á
à^ā * Á& } • d~ &c^ áÁæ Á@ Áá [, } • d^æ Áq ^Áq Á[áā æ^ Ác@ Á[[ç^ { ^ } Áæ áÁ& æá • Á[à^!ç^ áÁ+ [{ ÁFÉÍ ÉÉÁq Á
FÉÍ ÉÉÁ





Á

Photograph B7-9 Stormwater Dike

8 UH KÁ] c\ à\ ÁÍ ÉG FÍ Á D\ ch' Bi a VYf KÁ GÍ Á

8 YqWJdhcb KÁ [{ ÁUcá FÉÍ ÉÉÁ [\ q * Á ^• ÁÁÁ@Á&Á^• dÁXa, Á(-Á) • q } Á&Á&Á • Á@Á • cÁÁÁÁÁ } ^ÁÁ * ÁÁ Á
CE * • ÁG FÍ ÉV @ Á á\ iá Á -Á@ Á&Á • ÁÁÁÁ ÁÁÁÁÁ [{ ÁÉÍ ÉÉÁ ÁÉÍ ÉÉÁ



Á

Á

Photograph B7-10 Stormwater Dike

8 UH KÁ] c\ à\ ÁÍ ÉG FÍ Á D\ ch' Bi a VYf KÁ GJÁ

8 YqWJdhcb KÁ [{ ÁUcá FÉÍ ÉÉÁ [\ q * Á ^• ÁÁÁ@Á&Á^• dÁZ [{ Á } Á@Á) • q } Á&Á&Á • ÁÁÁÁÁÁÁÁÁ • [{ ^c\ ÉÁ



APPENDIX B5

Saddle Dam 3 Photographic Log and Record of Inspection



Photograph B5-1 Saddle Dam 3

8 U N Y A] c { à ! A I É C E F Í Á D l c h c ' B i a V Y f K U I Á

8 Y g W j d h c b k Q [{ Á q } | | c ā æ | ' Á c a Z C E Í F C Á [[\ ā * Á [~ c @ æ ó Á Á c @ Á & ! ^ • ó Á q á Á Á] • d ^ æ Á [[] ^ É Á



Photograph B5-2 Saddle Dam 3

8 U N Y A] c { à ! A I É C E F Í Á D l c h c ' B i a V Y f K U I Á

8 Y g W j d h c b k Q [{ Á c a Z C E Í F C Á [[\ ā * Á [~ c @ æ ó Á Á c @ Á & ! ^ • ó Á q á Á Á , } • d ^ æ Á [[] ^ É Á ! ^ • ^) & ^ Á [- Á æ ! Á
] [] á ā * Á q æ q • ó @ Á [, } • d ^ æ Á [[] ^ É Á



Photograph B5-3 Saddle Dam 3

8 U n K A ^] c { à ^ ! Á F I É G E F Í Á D \ c h c ' B i a V Y f k Á U Í Á

8 Y q W] d h c b k Q [{ Á u z G E Í í É Á [\ a * Á [! c @ ^ • c s a @ Á ! ^ • c s a @ Á ! , } • d ^ æ Á [] ^ Á s a Á É Á

) k e s a G E F Í a H] ! b F Í G F F A e { Á ^ (c & @ h •) Á G E F Í Á ^ a a [, a a \ d Á ! ^] a a a] Á - Á a ^ k ^ a a ^ a a [& F Í I J Á G E F Í Á ^ (c & @ a a a •) ^ & a) d ^ c Á G A H a] ^] a a k ^ a a] ^) a a Á Á Á e - a í Á a a a ^ Á a a Á h a í Á G e a a ^ Á a a Á h a] @ d Á (* Á G E F Í Á [& Á





APPENDIX B6

Saddle Dam 4 Photographic Log and Record of Inspection

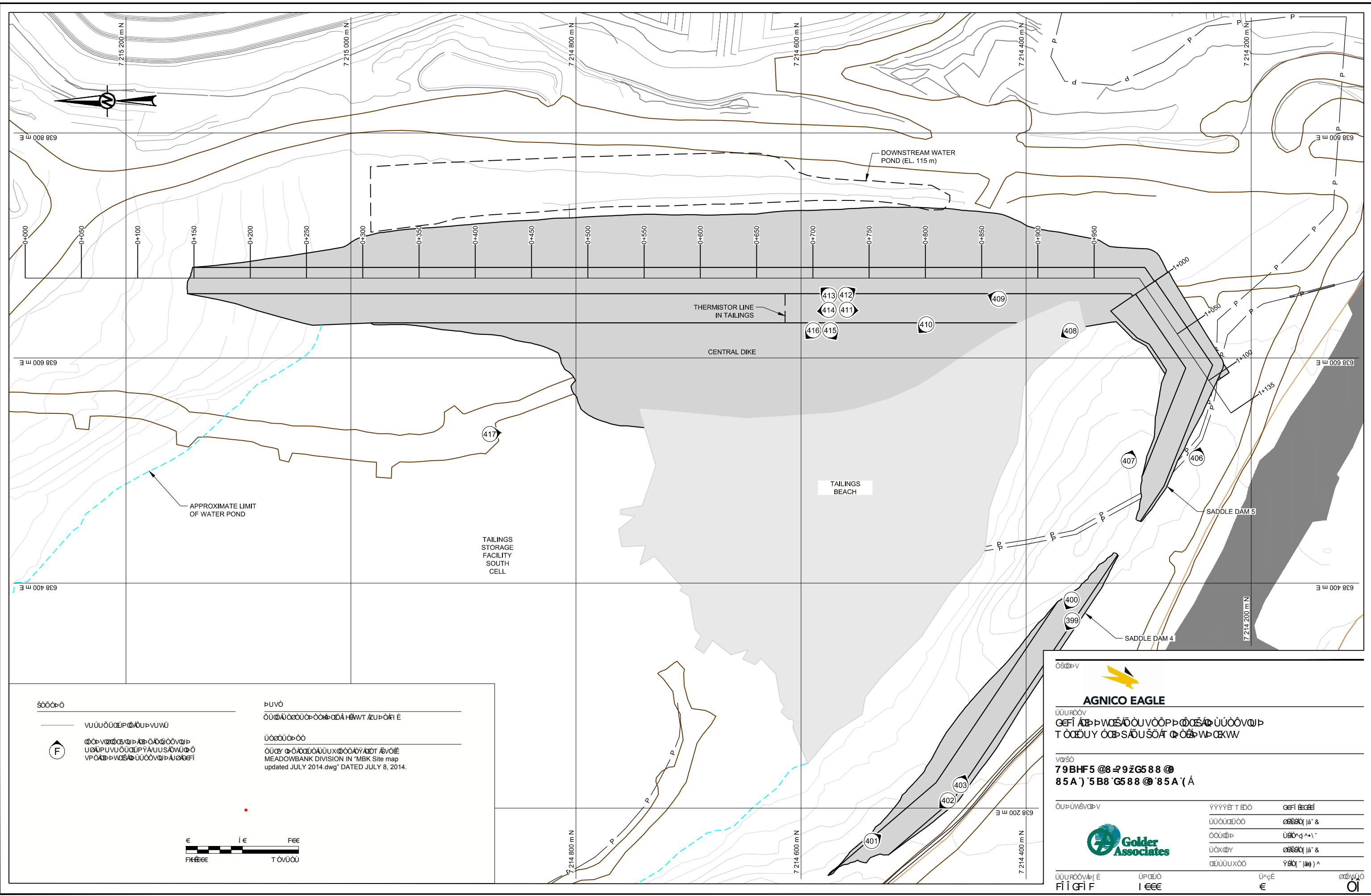

ΣΧΗΜΑΤΑ

ΥΠΟΛΟΓΙΣΜΟΣ ΠΡΟΣΑΡΜΟΓΗΣ

ΦΩΤΟΓΡΑΦΙΚΗ ΑΝΑΛΥΣΗ

ΥΠΟΛΟΓΙΣΜΟΣ ΠΡΟΣΑΡΜΟΓΗΣ

ΠΛΑΝΟ

ΟΡΘΟΓΩΝΙΟΜΕΤΡΙΚΟ ΔΙΑΓΡΑΜΜΑ ΖΥΓΙΟΓΡΑΦΙΑ

ΥΠΟΛΟΓΙΣΜΟΣ

ΟΡΘΟΓΩΝΙΟΜΕΤΡΙΚΟ ΔΙΑΓΡΑΜΜΑ

MEADOWBANK DIVISION IN "MBK Site map updated JULY 2014.dwg" DATED JULY 8, 2014.

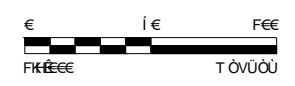

AGNICO EAGLE

ΥΠΟΥΡΧΟΝ

ΓΕΓΡΑΜΜΕΝΟ ΣΧΗΜΑΤΑ

ΤΟ ΟΥΔΕΝΩΣ ΕΠΙΣΤΑΣΕΩΣ

79BHF5 @ 8 29ZG5 88 @ 85A' 5B8' G588 @ 85A' (A)

ΟΡΘΟΓΩΝΙΟΜΕΤΡΙΚΟ ΔΙΑΓΡΑΜΜΑ

ΥΠΟΥΡΧΟΝ	ΥΠΟΥΡΧΟΝ	ΥΠΟΥΡΧΟΝ
ΥΠΟΥΡΧΟΝ	ΥΠΟΥΡΧΟΝ	ΥΠΟΥΡΧΟΝ
ΥΠΟΥΡΧΟΝ	ΥΠΟΥΡΧΟΝ	ΥΠΟΥΡΧΟΝ
ΥΠΟΥΡΧΟΝ	ΥΠΟΥΡΧΟΝ	ΥΠΟΥΡΧΟΝ

ΥΠΟΥΡΧΟΝ

ΥΠΟΥΡΧΟΝ

ΥΠΟΥΡΧΟΝ

ΥΠΟΥΡΧΟΝ

ΔΙΑΓΡΑΜΜΑ ΣΧΗΜΑΤΑ ΚΑΙ ΥΠΟΛΟΓΙΣΜΟΙ ΣΥΝΤΑΧΘΗΚΑΝ ΑΠΟ ΤΟΝ ΓΕΩΓΡΑΦΙΚΟ ΤΜΗΜΑ ΤΗΣ ΑΓΝΙΚΟ ΕΓΓΛΩΝ ΣΤΗΝ ΠΕΡΙΟΧΗ ΤΗΣ ΑΝΑΜΟΡΦΩΣΗΣ ΤΗΣ ΕΡΓΑΣΙΑΣ

ΔΙΑΓΡΑΜΜΑ ΣΧΗΜΑΤΑ ΚΑΙ ΥΠΟΛΟΓΙΣΜΟΙ ΣΥΝΤΑΧΘΗΚΑΝ ΑΠΟ ΤΟΝ ΓΕΩΓΡΑΦΙΚΟ ΤΜΗΜΑ ΤΗΣ ΑΓΝΙΚΟ ΕΓΓΛΩΝ ΣΤΗΝ ΠΕΡΙΟΧΗ ΤΗΣ ΑΝΑΜΟΡΦΩΣΗΣ ΤΗΣ ΕΡΓΑΣΙΑΣ



5 DD9 B8 ± '6 * '

F97 CF8 'C: '8 5 A 'BGD97 H-CB'

'BGD97 H-CB' 'H9 A'	C6 G9 F J5 H-CBG' 85 H5'	D< C HC'	7 CAA9 BHG/ 'CH<9 F'85 H5'
HĒÁ Ú[[] ^Á } * ^Á	FĒ P K X Á	Á	Á
HĒÁ Ú } . Á - Ö [. } Á	P [] ^ Á à • ^ Ç ^ á Á	Á	Á
HĒÁ Ú } . Á - Á [Ç ^ \ ^) ó Ç ^ \ { } á á } D	P [] ^ Á à • ^ Ç ^ á Á	Á	Á
HĒÁ Ö : á } . Á	P [] ^ Á à • ^ Ç ^ á Á	Á	Á
HĒÁ Ú ^ ^ } æ ^ Á Á ^ ó Ç ^ æ Á	P [] ^ Á à • ^ Ç ^ á Á } Á [] ^ Á	Á	Á
HĒÁ X ^ * ^ á } Á Ö [, ç Á	P [] ^ Á à • ^ Ç ^ á Á	Á	Á
HĒÁ U ç Á \ , ~ • æ Ö [} á á } . Á	P [] ^ Á	Á	Á
("8 CK BGHF95 A 'HC9 '5 F95 '	Á	H U J Ē Ē Ē Ē Ē Ē Ē Ē	Á
I Ē Á Ú ^ ^ } æ ^ Á [{ Ö á Á	P [Á	Á	Á
I Ē Á Ú } . Á - Ö [. } Á	P [] ^ Á à • ^ Ç ^ á Á	Á	Á
I Ē Á Ú } . Á - Á [à á á } Á Ú ^ ^ } æ ^ Á Y æ ^ Á	P [ó á } á á } ^ Á	Á	Á
I Ē Á Ö á & [: á } ç á } * Á	P [Á	Á	Á
I Ē Á U ^ ç ^ ó [^ á } * Á à { Á Ç Á } á á } ^ Á	P [ó á } á á } ^ Á	Á	Á
I Ē Á U ç Á \ , ~ • æ Ö [} á á } . Á	Y ^ . Á	Á	Ü) [- Á æ ^ Á & { ~ æ ^ Á ç Á á [, } • d ^ á Á á Á - Á ç Á d ' & ç ^ Á • { } Á á Á ^ Á ~ á á Á } d [Á ç Á æ ^ Á ç ^ Á [Á [^ Á [ó ç ^ á á ç Á ^ ç á } Á - Á ç ~ á á ç ^ Á - Á ç Á ~] • d ^ á Á ^ Á ç ^ Á ç Á
) "56 I HA9 BHGÁ	Á	Á	Á
I Ē Á Ú ^ ^ } æ ^ Á & [} á á [] ^ Á Ç á ç ^) ç { á á } \ { ^) ç Á	P [] ^ Á à • ^ Ç ^ á Á	Á	Á
I Ē Á Ú } . Á - Ö [. } Á	P [] ^ Á à • ^ Ç ^ á Á	Á	Á
I Ē Á Ö ç & • • á ^ Á ^ * ^ á } Á	P [Á	Á	Á
I Ē Á Ú ^ • ^ } & ^ Á - Á [á ^) ó Ö : [, • Á	P [] ^ Á à • ^ Ç ^ á Á	Á	Á
I Ē Á U ç Á \ , ~ • æ Ö [} á á } . Á	P [] ^ Á	Á	Á
* "F9 G9 F J C = Á	Á	Á	Á
I Ē Á Ú ç á á } Á - Á [] ^ Á	Ú ç á } ^ Á	Á	Á
I Ē Á Ö á ç } & ^ Á - Á ^ á • ó á ^ Á Ç Á } á á } ^ Á	P [] ^ Á à • ^ Ç ^ á Á	Á	Á
I Ē Á Ö ç æ ^ Á - Á á ^ Á [] { ^ Á Ç Á } á á } ^ Á	P [ó á } á á } ^ Á	Á	Á
I Ē Á Ø [á } * Á ^ á : á Á	P [] ^ Á à • ^ Ç ^ á Á	Á	Á
I Ē Á U ç Á \ , ~ • æ Ö [} á á } . Á	P [Á	Á	Á





5 DD9 B8 ± '6 * '

F97 CF8 'C: '8 5 A 'BGD97 HCB'

'BGD97 HCB' #9 A'	C6 G9 F J5 HCBG' 85 H5'	D<CHC'	7 CAA9 BHG/ 'CH<9 F'85 H5'
+ "9A9F; 9B7 MGD=@@K 5 M# CI H@HGHFI 7 HI F9 A	p[Á] ã, æ Á! Á~ q^ Á • d~ &c !^ Á çã o Æ } ^ Á â^, æ! ã * Á~ {] Æ	Á	Á
ï ÈÁ Û~ !-æ^ Á[} áã } Á	Á	Á	Á
ï ÈÁ Ûã } • Á -Á[• ã } Á	Á	Á	Á
ï ÈÁ Ûã } • Á -Á [ç^ (^) Á ç^ + { } æ } Á	Á	Á	Á
ï ÈÁ Ô! æ • Á	Á	Á	Á
ï ÈÁ Û^ ç^ (^) Á	Á	Á	Á
ï ÈÁ Û! • ^) & Á -Á ã! ã! Á Ó[& æ^ Á	Á	Á	Á
ï ÈÁ Ô[• ~ !^ Á ^ & çã } Á [] ^! æ } ç Á	Á	Á	Á
ï ÈÁ Û[] ^ Á! [ç & ç } Á	Á	Á	Á
ï ÈÁ Q • çã ã ç Á -Á ã^ Á [] ^ • Á	Á	Á	Á
ï ÈÁ Æ Á çã ! Á ~ • ~ ç Á [} áã } • Á	Á	Á	Á
, "BGHFI A9 BH5 HCBÁ	Á	Á	Á
ï ÈÁ Ûã: { { ^ ç! • Á	p[Á	Á	Á
ï ÈÁ Û^ ç^ (^) ç Ó^ • Á	p[Á	Á	Á
ï ÈÁ V@! { ç ç! • Á	ÿ^ • Á	Á	Û^ Á^ & ç } Á È Á - Á ç Á [] ! ç
ï ÈÁ Û^ ç^ (^) ç [] { ^) ç Á	p[Á	Á	Á
ï ÈÁ Û^ çã { [* ! ç ç Á	p[Á	Á	Á
ï ÈÁ Q ç ç [{ ^ ç! Á	p[Á	Á	Á
ï ÈÁ Y ^ á • Á ç á Á [, Á [] ç ! • Á	p[Á	Á	Ó [] • d~ & ç } Á! ç ç * • Á ç ç ç Á • ^ ^ ç ^ Á [] ^ & ç } Á ~ ç { ç ç Á Á & [] • d~ & ç á Æ
ï ÈÁ Ö ç ç [* * ^! ç Á	p[Á	Á	Á
ï ÈÁ U ç ç! Á	Á	Á	Á
- "8 C7 I A9 BH5 HCBÁ	Á	Á	Á
J È Á [] ^! ç ç } È Á ç ç ç & Á ç á Á Û~ ! ç^ ç ç & Á ç T U D Á ç Á	Á	Á	Á
Á J È È Á T Û Á ç ç ç Á	ÿ^ • Á	Á	Á
Á J È È Á T Û Á ç ç Á ^ + & ç Á & ! ! ^) ç ç ç Á [] áã } • Á	ÿ^ • Á	Á	Á
Á J È È Á Ö ç ç Á - ç ç ç ç } Á	T ç ç ç ç Á	Á	Á
J È Á (! * ^) & Á ! ^ ç ç á) ^ • Á ç Á ç Ó U D Á	Á	Á	Á



5 DD9 B8 ± '6 * '

F97 CF8 'C: '8 5 A 'BGD97 H-CB'

BGD97 H-CB' H9A'	C6 G9F J5 H-CBG' 85 H5'	D<CHC'	7 CAA9 BHG/ 'CH<9F'85 H5'
Á JÈÈFÀÓÚÚÁ çã • Á	ÿ^•Á	Á	Q&ÿ á^âÁ ã@ Á@ÁJT ÙÁã áÁÓÚÚÁ æ ÈÄ
Á JÈÈGÀÓÚÚÁ^~&• Á& !!^} óÁ & } áãã }•Á	ÿ^•Á	Á	Á
Á JÈÈHÖæ^Á-Áæ óÁ^çãã }Á	CE * ~ • óÁÈÍ Á	Á	Á

%\$ "BCH9G' ÁÁ

Á

bgdYWcfBj'G][bUifY		8 UHY.'	Ù^] ó{ à^!ÁÍ ÈÁÈÍ Á
---------------------	--	---------	---------------------

Á

}Kæ&æóÈÍ áHj!{ bFíí CFí FÁæ(Á^] ó&@ã •) ÁÈÈÍ Á ^æè[, áæ\ d Á!^] æææã }Á-Á^|ç^!æè|^•æ[&ÁÍ | JÁÈÈÍ Á^] ó&@ ææã •]^&ã } á^çÁÈÈÍ] ^) áæ^•æã] ^) áæ^ÁÁæ-æí Á ææá/^Áæç Á | æí ÁÁææá/^Áæç Á.Á.] ^&ã } ÁÈÈÍ È[&cÁ





5 DD9 B8 ± '6 * '
G588 @ '85 A ' & 'D < C H C ; F 5 D < 7 ' @ ; '



Á

Photograph B6-1 Saddle Dam 4

8 UH K U] c { à ! : A I É C E F Í Á D l c h c ' B i a V Y f K Á U J Á

8 Y g W j d h c b k Q [{ Á É I € € Á } ; [c ä æ ' Ë [[\ a * Á [| c @ ^ . c Á [{ Á @ Á ^ . c Á @ Á [, } . d ^ æ Á [] ^ Á } a Á ^ Ë



Á

Photograph B6-2 Saddle Dam 4

8 UH K U] c { à ! : A I É C E F Í Á D l c h c ' B i a V Y f K Á € € Á

8 Y g W j d h c b k Q [{ Á É € € € Á } ; [c ä æ ' Ë [[\ a * Á [| c @ ^ . c Á @ Á] . d ^ æ Á [] ^ Ë

Á



5 DD9 B8 ± 6 * '
G588 @ '85 A ' & 'D < C H C ; F 5 D < 7 ' @ ; '



Photograph B6-3 Saddle Dam 4

8 U N K U ^] c { à \ / Á F I É G F Í Á D \ c h c ' B i a V Y f Á É Á

8 Y g W] d h c b k Q [{ Á É F Í É Á } ! [c ä æ \ ' É [[\ ä * Á [: @ æ ó á @ & \ ^ • ó á á @ Á] • d ^ æ Á [] ^ É Á



Photograph B6-4 Saddle Dam 4

8 U N K U ^] c { à \ / Á F I É G F Í Á D \ c h c ' B i a V Y f Á É Á

8 Y g W] d h c b k Q [{ Á É G Í É Á } ! [c ä æ \ ' É [[\ ä * Á [: @ ^ • ó á @ & \ ^ • ó á á @ Á] , } • d ^ æ Á [] ^ É Á á Á ^ É Á





APPENDIX B7

Central Dike and Saddle Dam 5 Photographic Log and Record of Inspection



5 DD9 B8 ± '6) ' F97 CF8 'C: '8 5 A 'BGD97 H-CB'

7 'Ybh' ØØT Á 6 m' Ýç^•ÁÓ[~ |ã] } ^Á
 Dfc 'YWh' T ^æ[, àæ \ Á 8 UH.' Ù] ç{ à^!Á! ÈGEFÍ Á
 @WUjcb.' Ô} dæÄÖá ^Áæ àÁæá^!Öæ Á Á F Yj JYk YX.' Ýç^•ÁÓ[~ |ã] } ^Á

; 9B9F5 @-B: CFA5H-CB'

8 Ua 'HndY.' Ü[& ç]Á{ àæ \ { ^} ó äöç ç^!ç^!ç^!Á } Áæ^È^ Á^ } &@Á] • d^æ Áç^! ÈÁ^ { ^{ ààè ^ ç^!Á ç^!Á ç^!Á } * Á ç^!Á [ç^!Á ç^!Á

K YUH Yf '7 cbX]jcbg.' Uç^!æç^! HYa dYfUi fY.' Í »ÔÁ

'BGD97 H-CB' ±9A'	C6 G9F J5 H-CBG' 85 H5'	D<CHC'	7CAA9BHG/ 'CH<9F'85 H5'
%'85A '7F9GH		I FFÈÁ FÍ Á	
FÈÁ Ô!^•óÖ!çæ] } Á	Ô! -!áæ ÁÖ!^•óÄFFEÁ Á Ü[& ç]Á{ àæ \ { ^} ó äöç ç^!ç^!ç^!Á		
FÈÁ Ü^•!ç[äÁç^!Á	FHEÁ Á Äæ^!Á FHGE Á Äæç^! * Á		
Ô! !^} óÄ^!à[æáÁ	FÈÁ Á { Á@Á^•ó		
FÈÁ Öæ çæ &Á/ Áæç^! * ÁÜ } áÁ ç^!Á] æá^!Á	Xæá^!Á		Væç^! * Á^!æç^! çæ çæ • ó@Á [~ ç@!] Á æ^!Á ç^!É ç^!Á ÁÉ! í ç^!Á] çæ çæ^! Dá^! ç^!Á [] Á@Á [!ç@!] Á æ^!Á
FÈÁ Ü! -æ^!ÁÖ!æá ç^! * Á	P[] ^!æç^! ^!Á - ç^!] ^!ç^!Á		
FÈÁ Wj ^ç] ^&ç^!ÁÜç^! { ^} ó	P[] ^!Á à^!ç^!áÁ		
FÈÁ Šæç^!ç^! [ç^! { ^} ó	P[ç^!] æ^! ó		
FÈÁ Uç@!ÁVj ~ • ç^!Ö[] áæç^! • Á			
&'I DGHF95A 'G@CD9		I éi ÈÁ éi È FÈÁ FÍ ÈÁ I FÍ ÈÁ FÍ Á	
GEÁ Ü[] ^!ç^! * ^!Á	HFXÁ] Á ÖÈÁHEÁ Á çæ áÁGPHXÁ [ç^!Á		
GEÁ Üæ } • Á -Ö[] • ç^! } Á	P[] ^!Á à^!ç^!áÁ		
GEÁ Üæ } • Á -Á [ç^! { ^} ó ç^! { { çæ } Á	P[] ^!Á à^!ç^!áÁ		
GEÁ Ô!æá • Á	P[] ^!Á à^!ç^!áÁ		
GEÁ Öæ^!ç^! ^!Á [] áæç^! } Á ç^!Á] æá^!Á			Šç^! ^!Á ç^! ^!Á Á çæ çæ^! çæ Á] [ç^!ç^!] Á ç^!Á] Á ÖÈÁFG Á ÈÁ
GEÁ Uç@!ÁVj ~ • ç^!Ö[] áæç^! • Á	P[] ^!Á		





5 DD9 B8 ± '6) '
 F97 CF8 'C: '8 5 A 'BGD97 H-CB'

'BGD97 H-CB' #H9 A'	C6 G9 FJ5 H-CBG' 85 H5'	D<CHC'	7 CAA9 BHG/ 'CH<9F'85 H5'
î ěÁ Ø[ææ * Å^à:ãÁ	Þ[]^Å à•^!ç^ãÁ	Á	Á
î ěÁ U@!ÁV}~•~ æ/Ö[] åãæ }•Á	Þ[Á	Á	Á
+ "9A9F; 9B7 MGD=@@K 5M# CI H@'HGFI 7HI F9Á	Þ[Á] æ, æ Å! Å~ ç^óÁ •d~ &c!^Å çã • Å } Á à^, æ^!ã * Å~ { } Å	Á	Á
î ěÁ Û~!-æ^ÅÖ[] åãæ }Á	Á	Á	Á
î ěÁ Ûã }•Å -ÅÖ[]•ã }Á	Á	Á	Á
î ěÁ Ûã }•Å -Å [ç^ ^) óÁ Ç^+!{ ææ } Å	Á	Á	Á
î ěÁ Ö:ææ•Á	Á	Á	Á
î ěÁ Û^ç^ ^) óÁ	Á	Á	Á
î ěÁ Û!^•^} &Å -Å^à:ã Å!Á Ö[] & æ^Á	Á	Á	Á
î ěÁ Ö[]•~!^Å ^&@æ } Å []^!ææ } æÁ	Á	Á	Á
î ěÁ Û[]^Å[] ç^ç }Á	Á	Á	Á
î ěÁ Q•æææç Å -Å^Å[]^•Á	Á	Á	Á
î ěÁ U@!ÁV}~•~ æ/Ö[] åãæ }•Á	Á	Á	Á
, "BGHFI A9BH5 H-CBÁ	Á	Á	Á
î ěÁ Ûã: [{ ^ç!•Á	ÿ^•Á	Á	Û^^Á^&ç } Á ěÁ
î ěÁ Û^ç^ ^) óÁ •Á	Þ[Á	Á	Á
î ěÁ V@!{ æ ç!•Á	ÿ^•Á	Á	Û^^Á^&ç } Á ěÁ
î ěÁ Û^ç^ ^) óÁ [] { ^) çÁ	Þ[Á	Á	Á
î ěÁ Ûã { [*!æ @Á	Þ[Á	Á	Á
î ěÁ Q&æ [{ ^ç!Á	Þ[Á	Á	Á
î ěÁ Y^ã•Å æ åÁ[], Å [] æ!•Á	Þ[Á	Á	Á
î ěÁ Öææ[**^!çÁ	Þ[Á	Á	Á
î ěÁ U@!Á	Á	Á	Á
- "8C7I A9BH5 H-CBÁ	Á	Á	Á
JĚÁÚ] ^!ææ } ěĚ æ ç } æ &Å æ åÁ Û~!ç^ãæ } &Å ÚT ÚDÚæ } Á	Á	Á	Á
Á JĚĚÁÚT ÚÁÚæ } Å çã •Á	ÿ^•Á	Á	Á
Á JĚĚÁÚT ÚÁÚæ } Å^~&•Á &!!^) óæ } &[] åãæ }•Á	ÿ^•Á	Á	Á
Á JĚĚÖæ Å -Å ç^ç } Á	T æ&ççĚĚ Á	Á	Á





5 DD9 B8 ± '6) '

F97 CF8 'C: '8 5 A 'BGD97 H-CB'

BGD97 H-CB 'H9 A'	C6 G9 FJ5 H-CBG' 85 H5'	D<CHC'	7 CAA9 BHG/ 'CH<9F'85 H5'
JEGÖ(^!*^) & ÁU ^} æ^â} ^••Á U æ ÁÇÓÚÁ	Á	Á	Á
Á JÈÈÁÓÚÚÁçä çÁ	ÿ^•Á	Á	Q&ÿ á^âÁ æ@ Á@ÁUT ÚÁæ áÁÓÚÚÁ æ ÈÁ
Á JÈÈÁÓÚÚÁ^~& Á& !!^} çÁ &{ } äää }•Á	ÿ^•Á	Á	Á
Á JÈÈÁÖæ^ Á Áæ çÁçä ä } Á	CE *~• çÁÇEFÍ Á	Á	Á

%\$"BCH9G'..'

Á

.

bgdYWwcfBj'G][bUli fY	8 UY.'	Ù^} ç{ à^!ÁFI ÈÁÇEFÍ Á
------------------------	--------	------------------------

Á

) Kæ&çäÇEFÍ dHj|{ bFÍÍ ÇFI FÁæ(Á^| ç&@#•) ÁÇEFÍ Á ^æ[, àæ\ d Á|^} æææ } Á Á^|ç^|æ|æ|^æ[&ÁFI | JÁÇEFÍ Á^| ç&@ ææ# •) ^&ç } d^ç/ÇdHæj] ^) äæ^•æj] ^) äæ#ÁÈæ-æí Á^| çæ#ä^È
 •áí äí ÁÈ^| çæ#ä^È æáÁæä|Áææ Á Á# •) ^&ç } ÁÇEFÍ È[&çÁ





APPENDIX B5 CENTRAL DIKE PHOTOGRAPHIC LOG



Photograph B7-1 Central Dike

Date: September 14, 2016

Photo Number: 417

Description: From the north of Central Dike within the South Cell looking south. View of the upstream slope of Central Dike. There is water ponding directly against the north section of the structure.



Photograph B7-2 Central Dike

Date: September 14, 2016

Photo Number: 416

Description: From approximately Sta. 0+700, looking northwest at the upstream slope. Adequate tailings beach against the south section of the structure.



APPENDIX B5 CENTRAL DIKE PHOTOGRAPHIC LOG



Photograph B7-3 Central Dike

Date: September 14, 2016

Photo Number: 415

Description: From approximately Sta. 0+700 looking southwest at the upstream slope. Adequate tailings beach against the south section of the structure.



Photograph B7-4 Central Dike

Date: September 14, 2016

Photo Number: 410

Description: From approximately Sta. 0+800 on the crest, looking northwest at the upstream slope and a tailings deposition finger.



APPENDIX B5 CENTRAL DIKE PHOTOGRAPHIC LOG



Photograph B7-5 Central Dike

Date: September 14, 2016

Photo Number: 408

Description: From approximately Sta. 0+920 looking northwest at the upstream slope.



Photograph B7-6 Central Dike

Date: September 14, 2016

Photo Number: 409

Description: From approximately Sta. 0+870 looking northeast at the crest and the downstream slope. View of the downstream pond and pumping system.



APPENDIX B5 CENTRAL DIKE PHOTOGRAPHIC LOG



Photograph B7-7 Central Dike

Date: September 14, 2016

Photo Number: 412

Description: From approximately Sta. 0+720 looking southeast at the downstream slope and toe. View of the downstream pond and pumping system.



Photograph B7-8 Central Dike

Date: September 14, 2016

Photo Number: 413

Description: From approximately Sta. 0+720 looking northeast at the downstream slope and toe. View of the downstream pond and pumping system.



APPENDIX B5 CENTRAL DIKE PHOTOGRAPHIC LOG



Photograph B7-9 Central Dike

Date: September 14, 2016

Photo Number: 411

Description: From approximately Sta. 0+720 looking south at the crest.



Photograph B7-10 Central Dike

Date: September 14, 2016

Photo Number: 414

Description: From approximately Sta. 0+720 looking north at the crest.



APPENDIX B5 CENTRAL DIKE PHOTOGRAPHIC LOG



Photograph B7-11 Saddle Dam 5

Date: September 14, 2016

Photo Number: 406

Description: From 40+620 downstream, looking southeast at the downstream toe area.



Photograph B7-12 Saddle Dam 5

Date: September 14, 2016

Photo Number: 407

Description: From 40+620 upstream, looking southeast at the upstream toe area.

n:\actif\2016\3 proj\1662181 aem geotech insp 2016 meadowbank\5 preparation of deliverables\doc 1549 2016 geotechnical inspection\rev 0\3 appendices\appendix b - tsfb7 central dike-sd5\b7 - central dike photo log 2016.docx



APPENDIX C

Geotechnical Instrumentation Data



APPENDIX C1

Dewatering Dikes Instrumentation Data

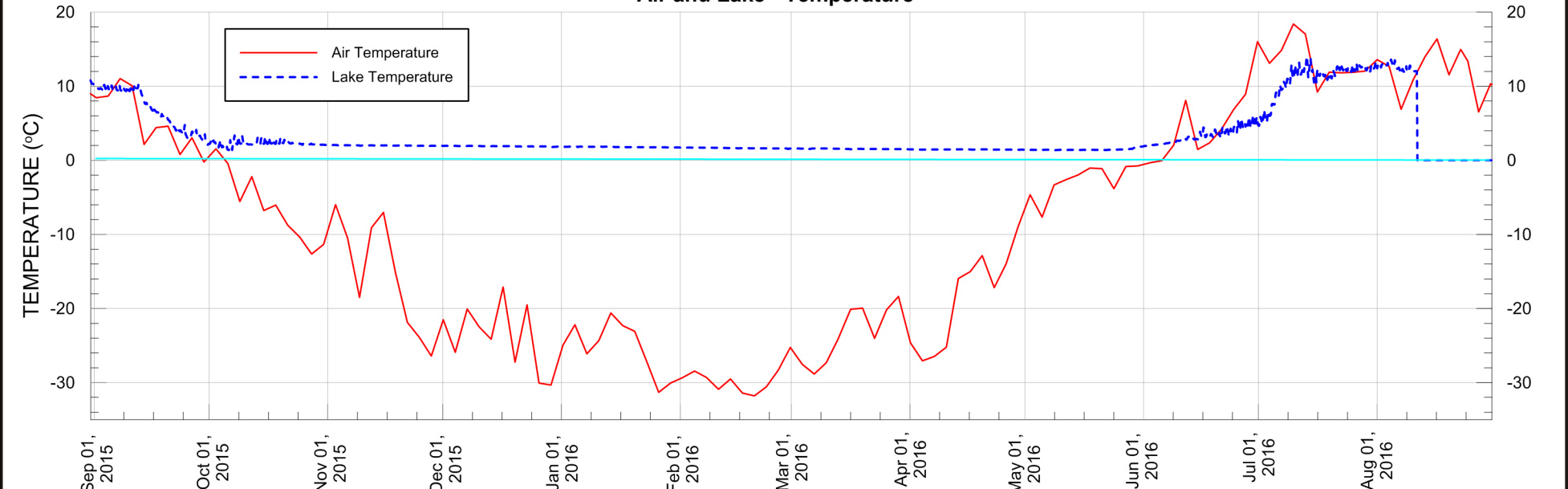
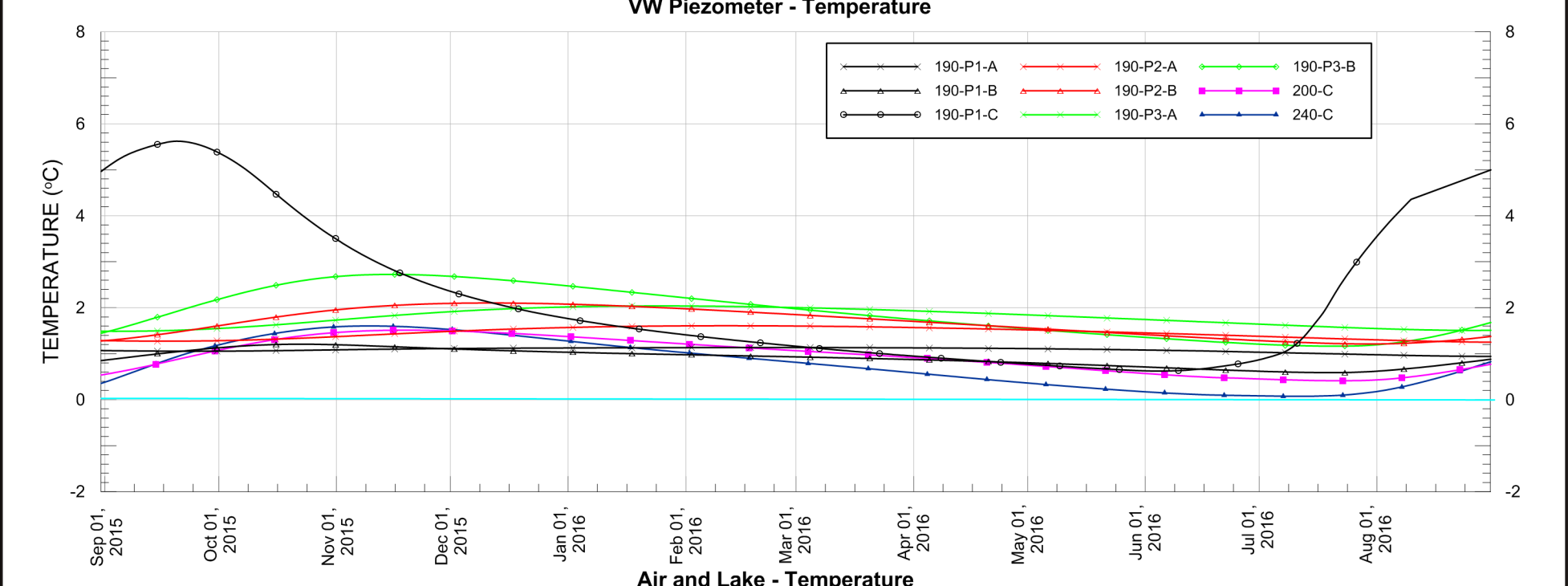
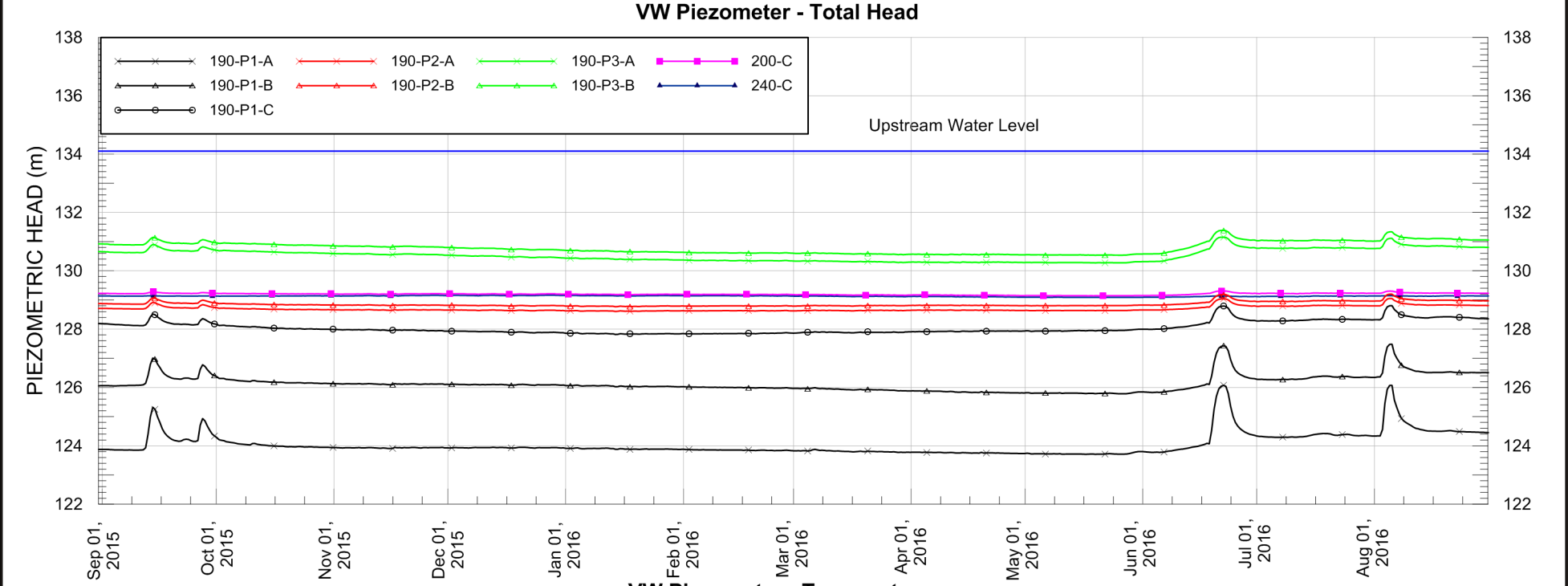
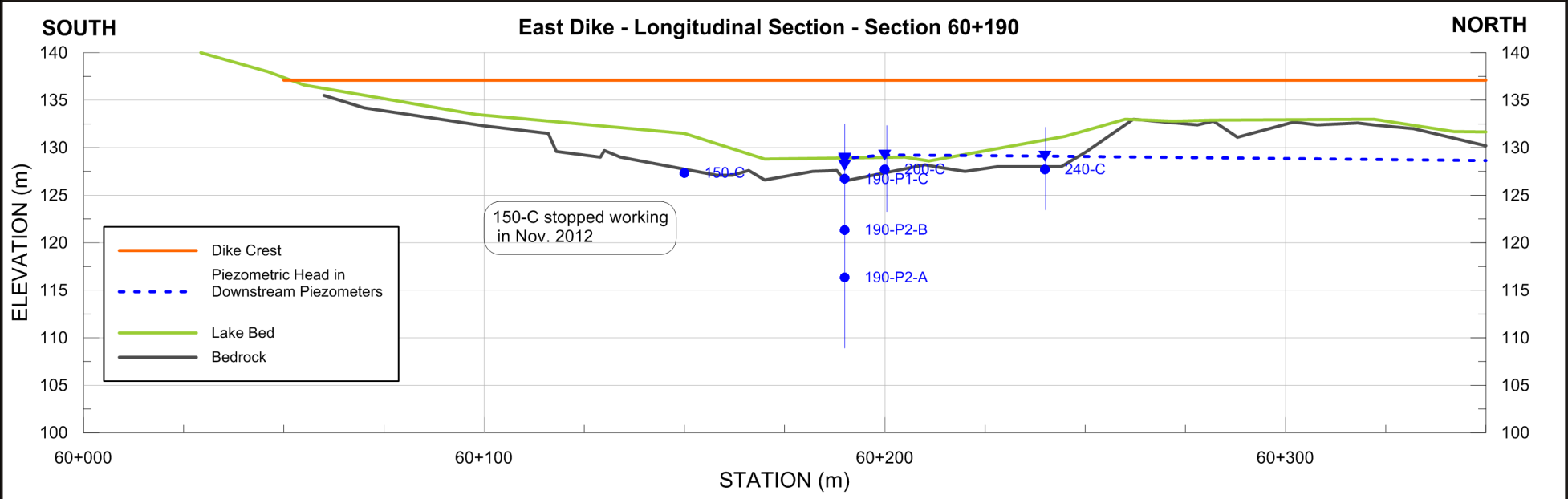

PROJECT					AGNICO EAGLE MINES LIMITED MEADOWBANK GOLD PROJECT NUNAVUT				
TITLE					EAST DIKE Section 60+190 - PIEZOMETRIC DATA (Aug 31/15 to Aug 31/16)				
		PROJECT No.			PHASE No.				
		DESIGN	TD	28AUG14	SCALE	AS SHOWN	REV.		
		CADD	TD	28AUG14	FIGURE 45				
		CHECK	PG	28AUG14					
REVIEW									

East Dike - Longitudinal Section - Station 60+350 to 60+550

SOUTH

NORTH

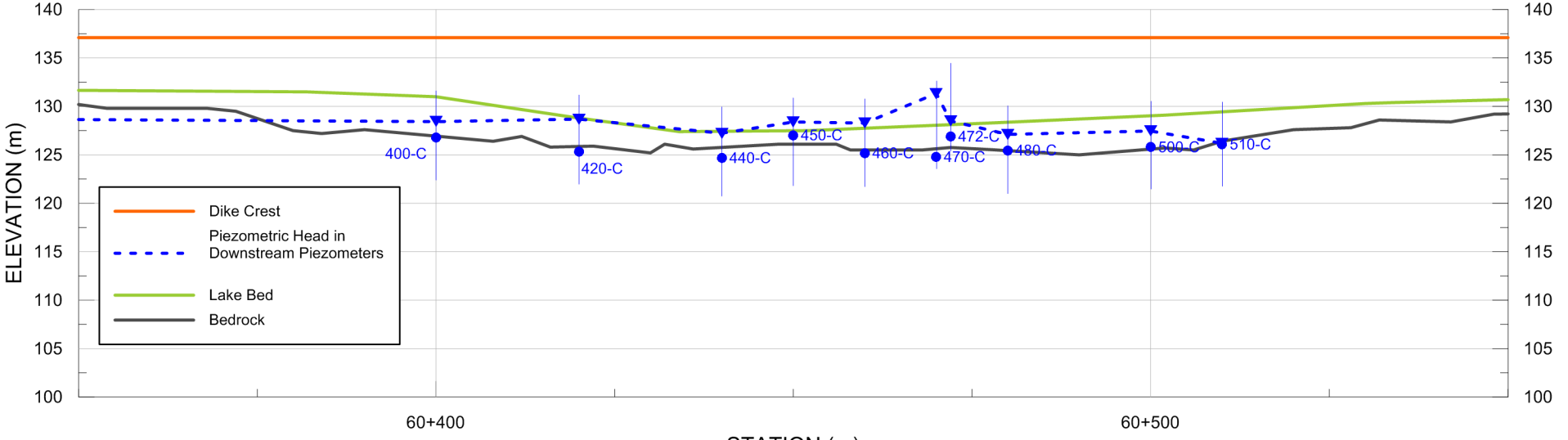

VW Piezometer - Total Head

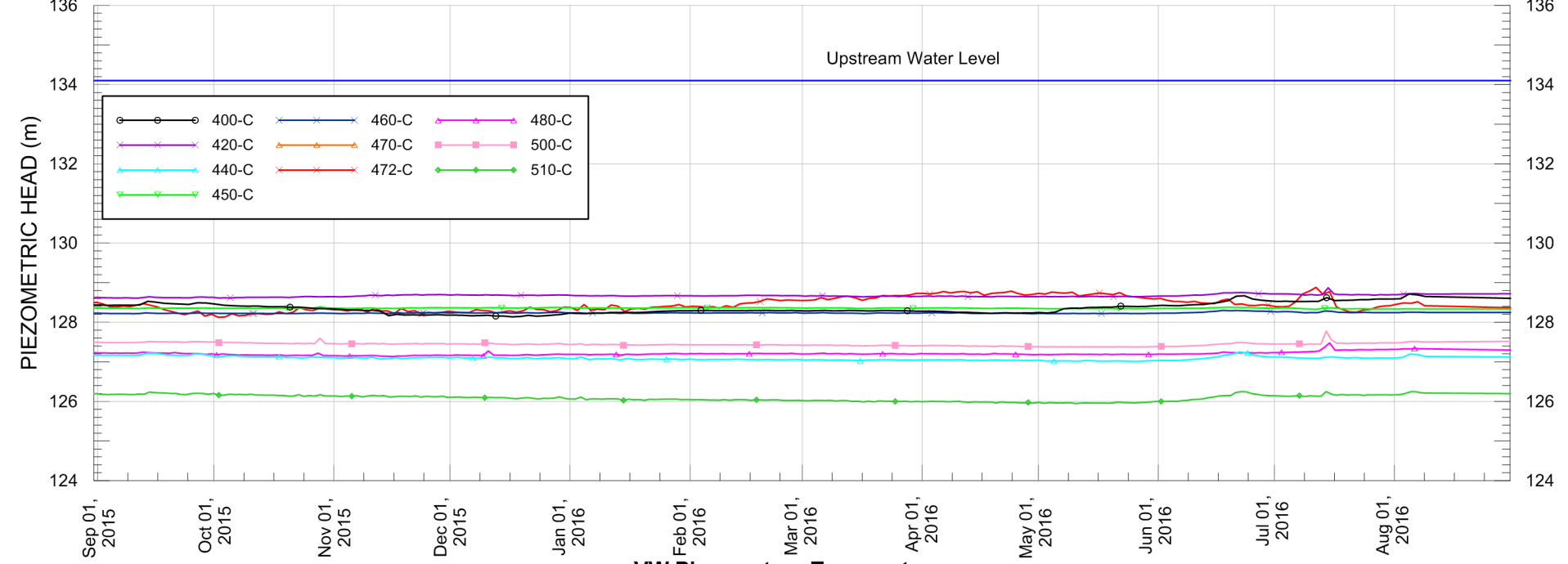

VW Piezometer - Temperature

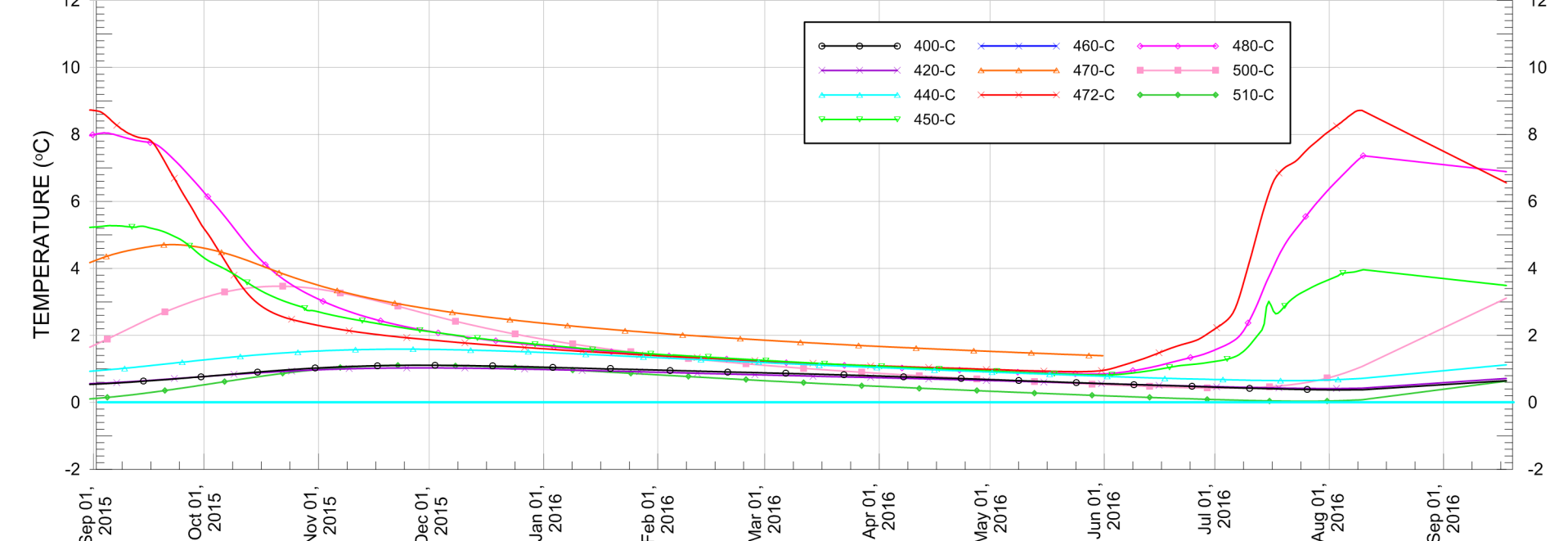

Air and Lake - Temperature

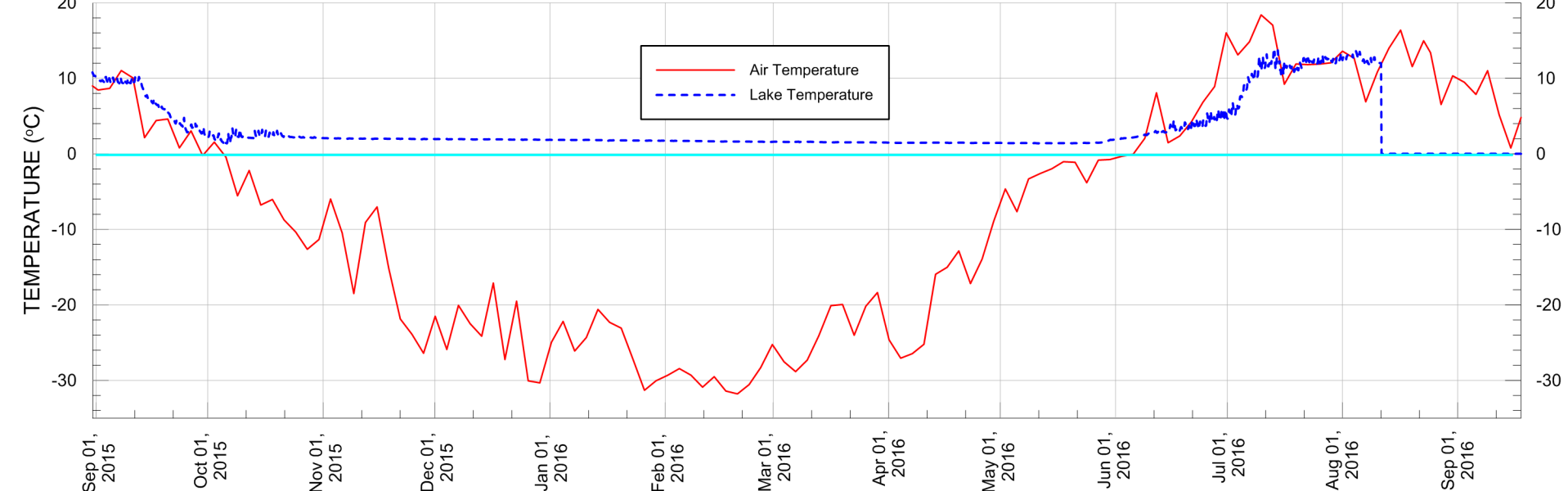

PROJECT **AGNICO EAGLE MINES LIMITED
MEADOWBANK GOLD PROJECT
NUNAVUT**

TITLE **EAST DIKE
Section 60+350 to 60+550 - PIEZOMETRIC
DATA (Aug 31/15 to Aug 31/16)**

	PROJECT No.			PHASE No.		
	DESIGN	TD	28AUG14	SCALE	AS SHOWN	REV.
	CADD	TD	28AUG14	FIGURE 47		
	CHECK	PG	28AUG14			
	REVIEW					

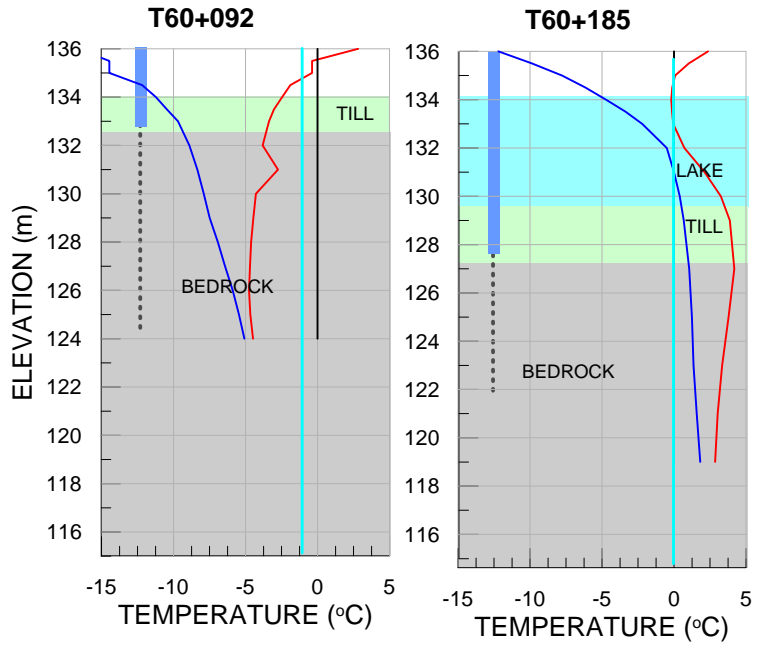
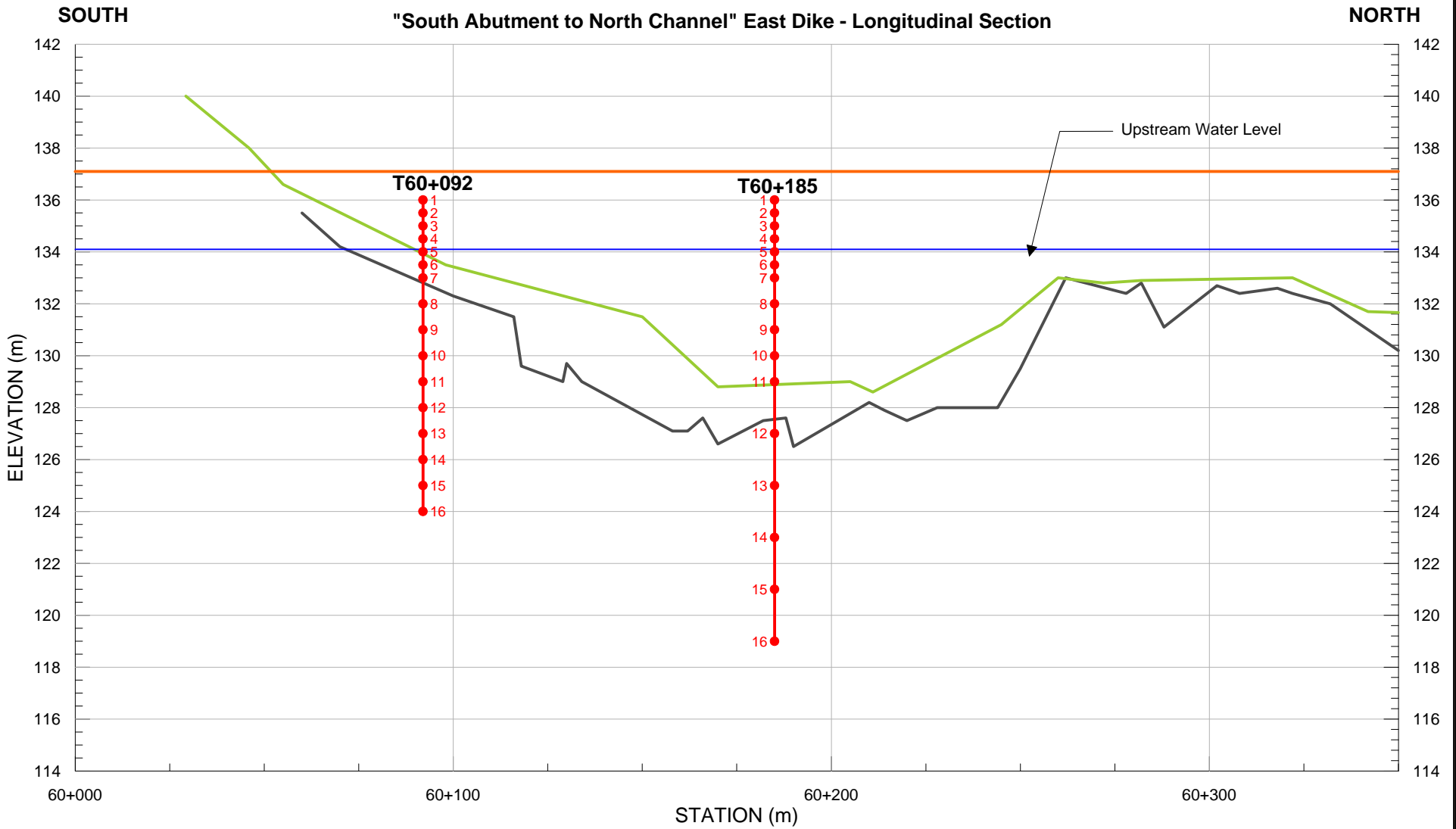

LEGEND

- Dike Crest
- - - Piezometric Head in Downstream Piezometers
- Lake Bed
- Bedrock
- █ Lake
- █ Till
- █ Bedrock
- Vibrating Wire Piezometer Installation Level
- █ SB
- █ CSB
- █ Jet Grouting
- █ Grouting
- 6 Thermistor with Bead Locations
- 7
- 8
- 9
- T min
- T current
- T max

NOTES:
1.

PROJECT		AGNICO EAGLE MINES LIMITED MEADOWBANK GOLD PROJECT NUNAVUT		
TITLE		EAST DIKE 60+000 to 60+350 - TEMPERATURE DATA (Aug 31/15 to Aug 31/16)		
	PROJECT No.	PHASE No.		
	DESIGN	TD	20JAN14	SCALE AS SHOWN
	CADD	TD	20JAN14	REV.
	CHECK			
REVIEW				FIGURE 57

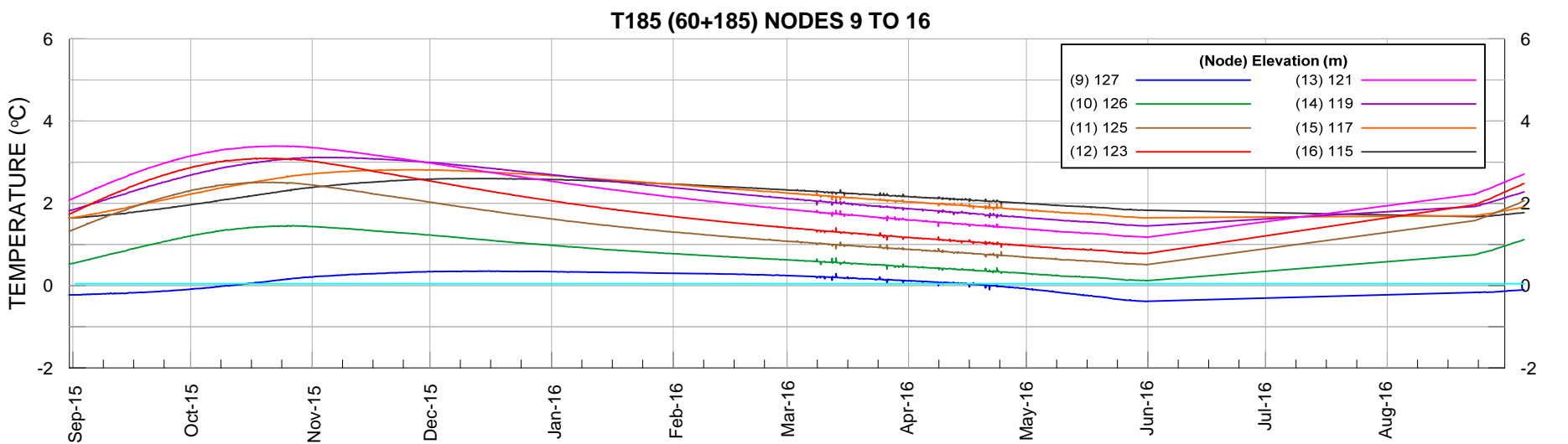
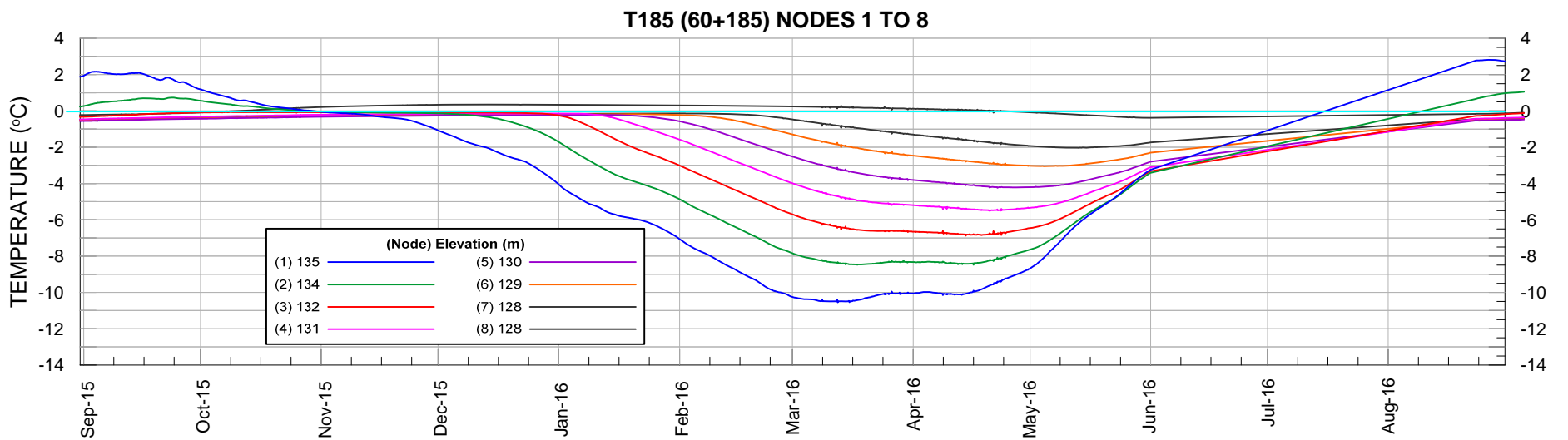
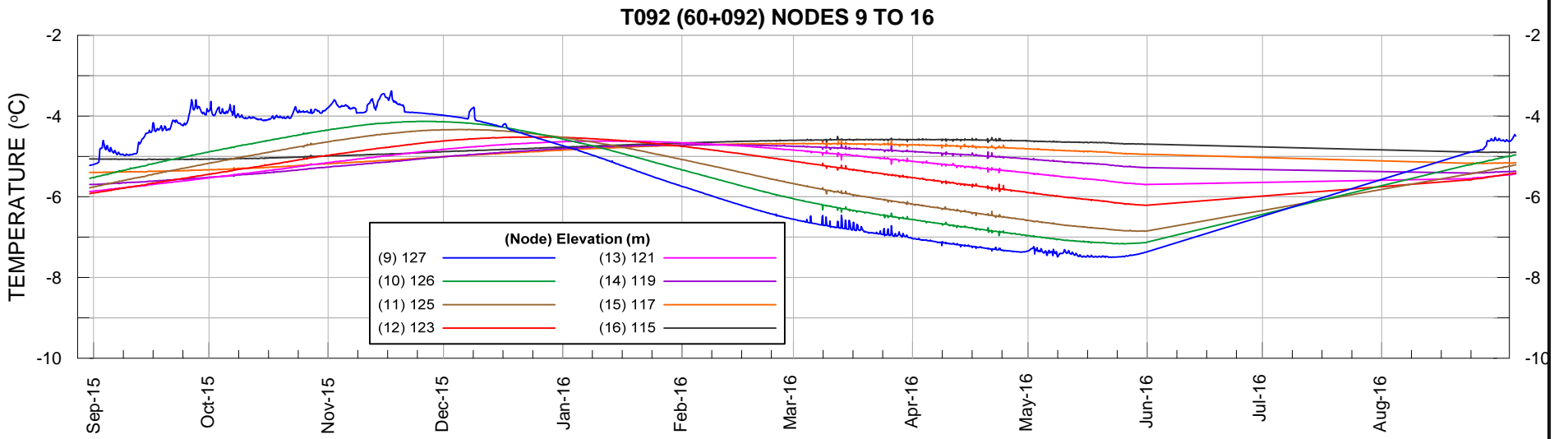
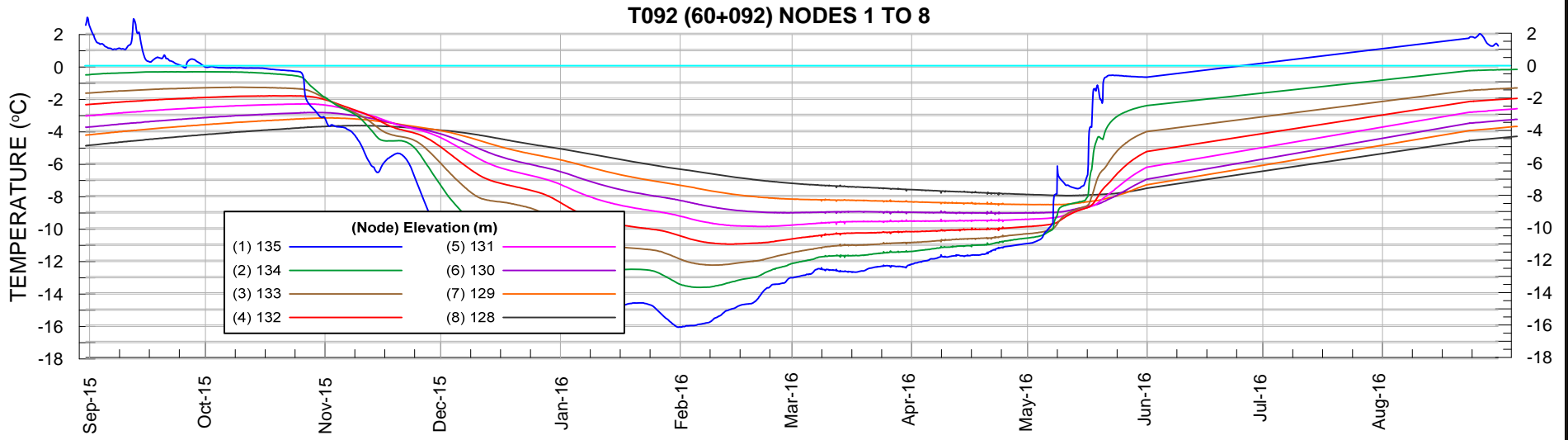

PROJECT	AGNICO EAGLE MINES LIMITED MEADOWBANK GOLD PROJECT NUNAVUT			
TITLE	EAST DIKE NODAL THERMAL TIMELINES (Aug 31/15 to Aug 31/16)			
	PROJECT No.		PHASE No.	
	DESIGN	TD	20JAN14	SCALE AS SHOWN
	CADD	TD	20JAN14	REV.
	CHECK			
REVIEW				FIGURE 58

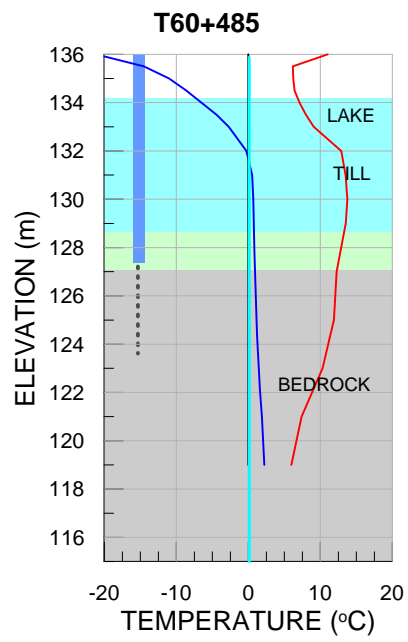
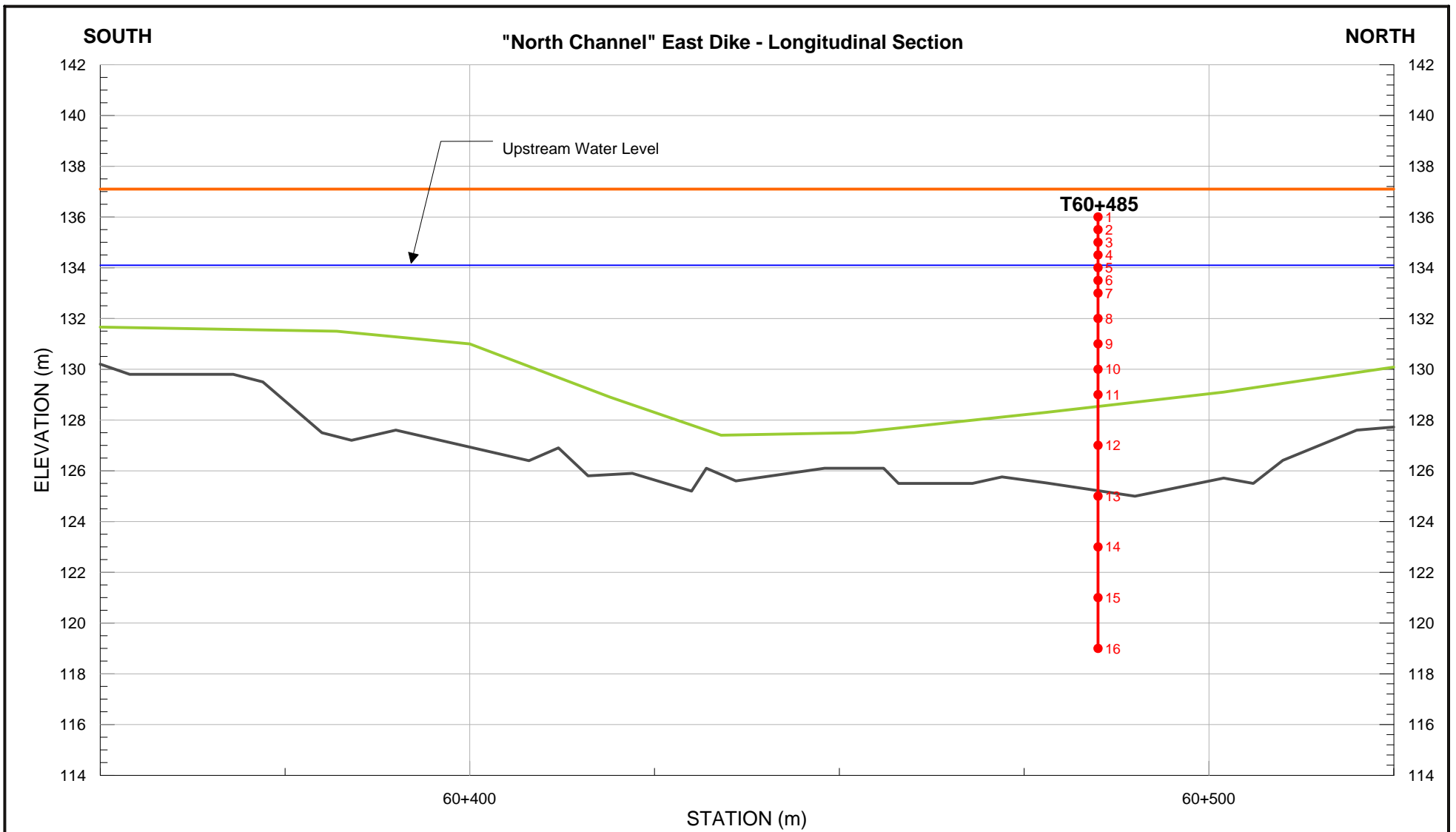

LEGEND

- Dike Crest
- - - Piezometric Head in Downstream Piezometers
- Lake Bed
- Bedrock
- Lake
- Till
- Bedrock
- Vibrating Wire Piezometer Installation Level
- 6 Thermistor with Bead Locations
- 7
- 8
- 9
- SB
- CSB
- Jet Grouting
- Grouting
- T min
- T current
- T max

NOTES:
1.

PROJECT		AGNICO EAGLE MINES LIMITED MEADOWBANK GOLD PROJECT NUNAVUT		
TITLE		BAYGOOSE DIKE 60+350 to 60+525 - TEMPERATURE DATA (Aug 31/15 to Aug 31/16)		
	PROJECT No.		PHASE No.	
	DESIGN	TD	20JAN14	SCALE AS SHOWN
	CADD	TD	20JAN14	REV.
	CHECK			
	REVIEW			FIGURE 58

T485 (60+485) NODES 1 TO 8

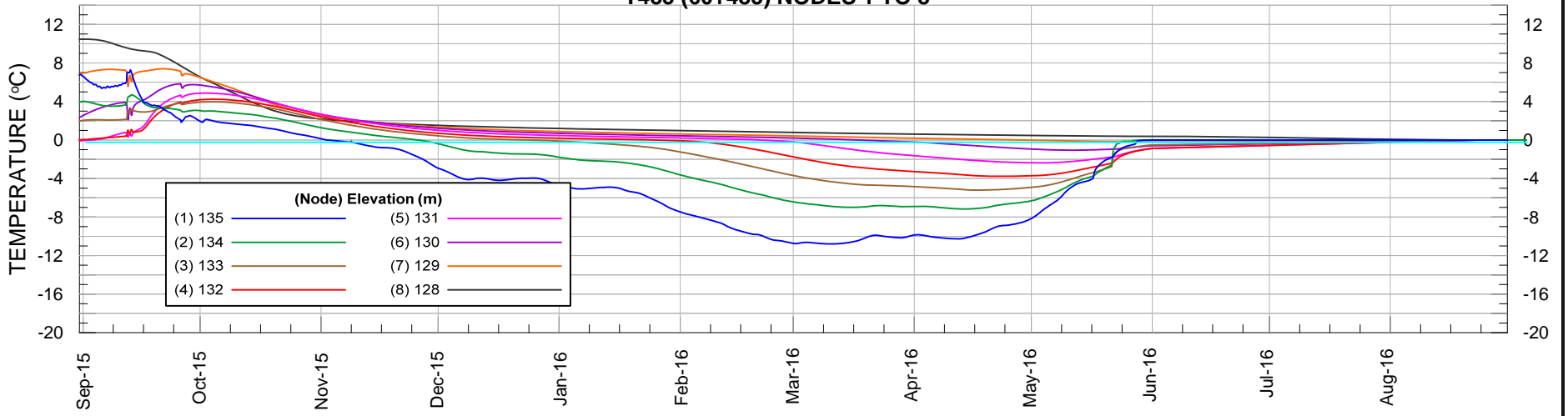

T485 (60+485) NODES 9 TO 16

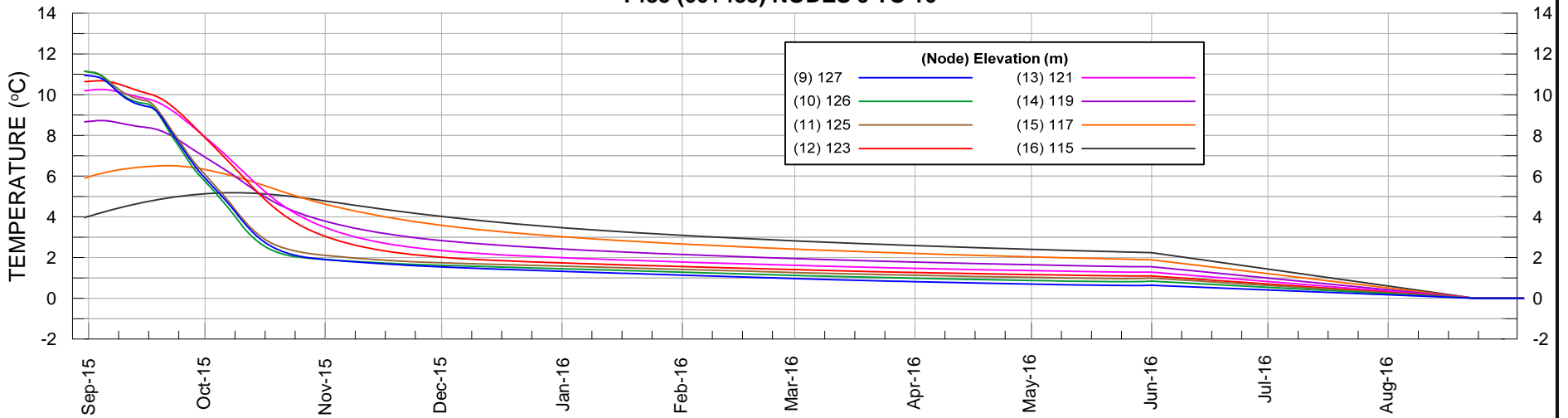

T695 (60+695) NODES 1 TO 8

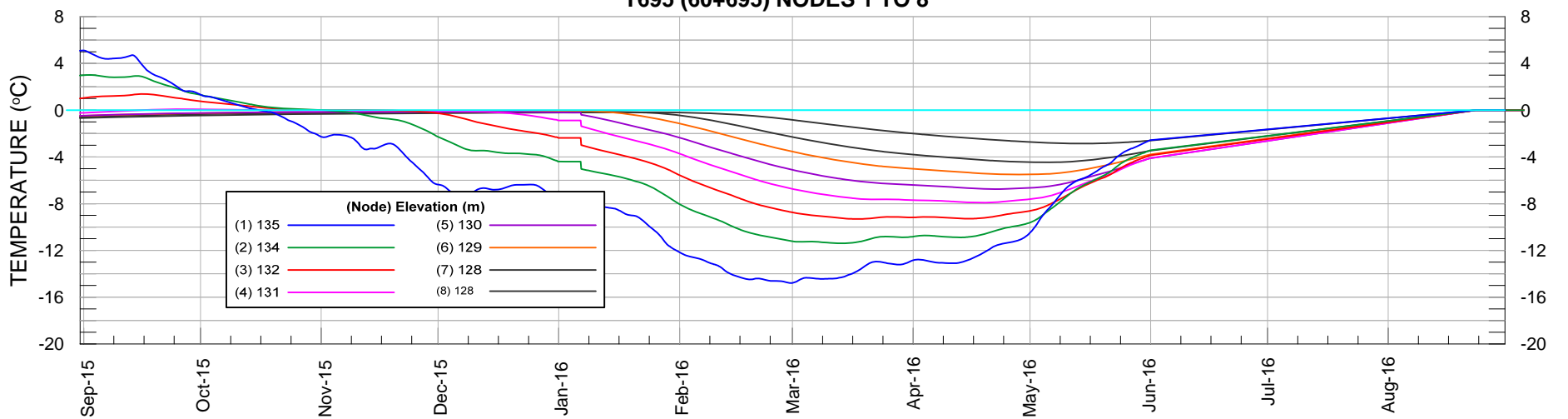

T695 (60+695) NODES 9 TO 16

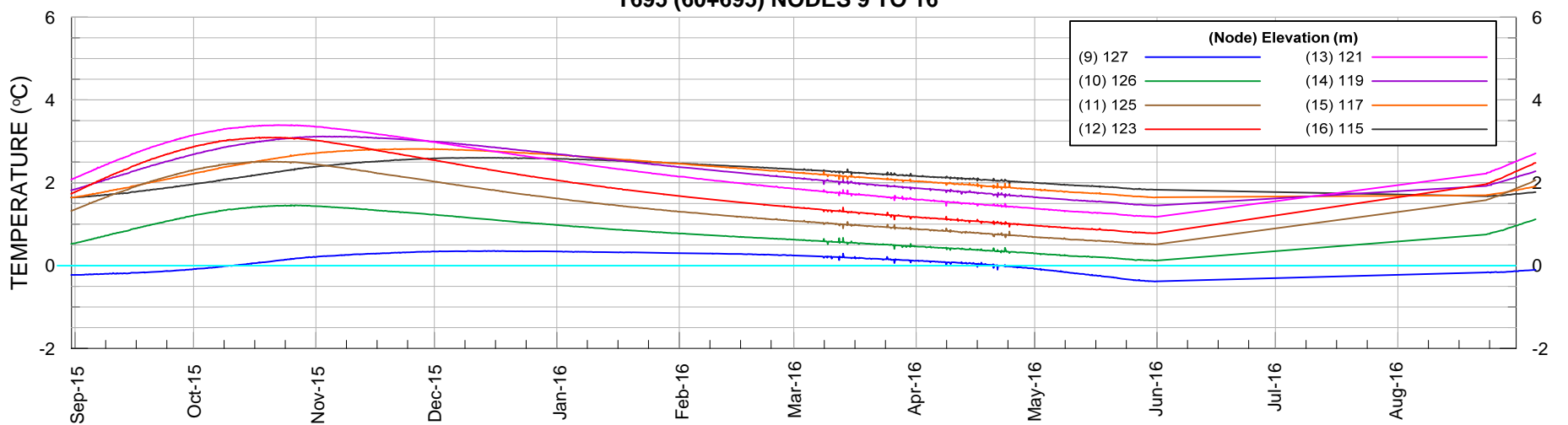

PROJECT		AGNICO EAGLE MINES LIMITED MEADOWBANK GOLD PROJECT NUNAVUT			
TITLE		EAST DIKE NODAL THERMAL TIMELINES (Aug 31/15 to Aug 31/16)			
	PROJECT No.	PHASE No.		FIGURE 60	
	DESIGN	TD	20JAN14		SCALE AS SHOWN
	CADD	TD	20JAN14		REV.
	CHECK				
REVIEW					

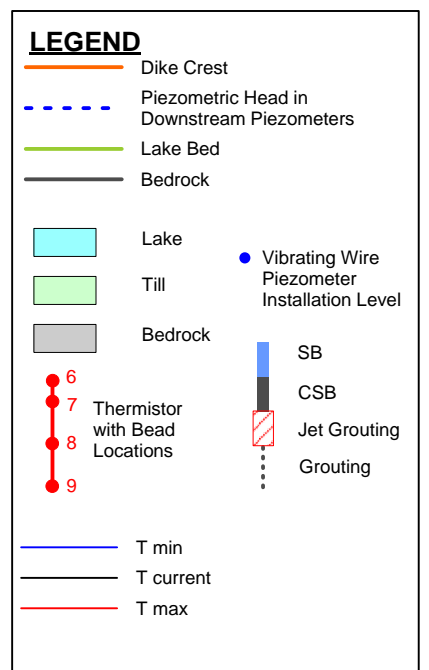
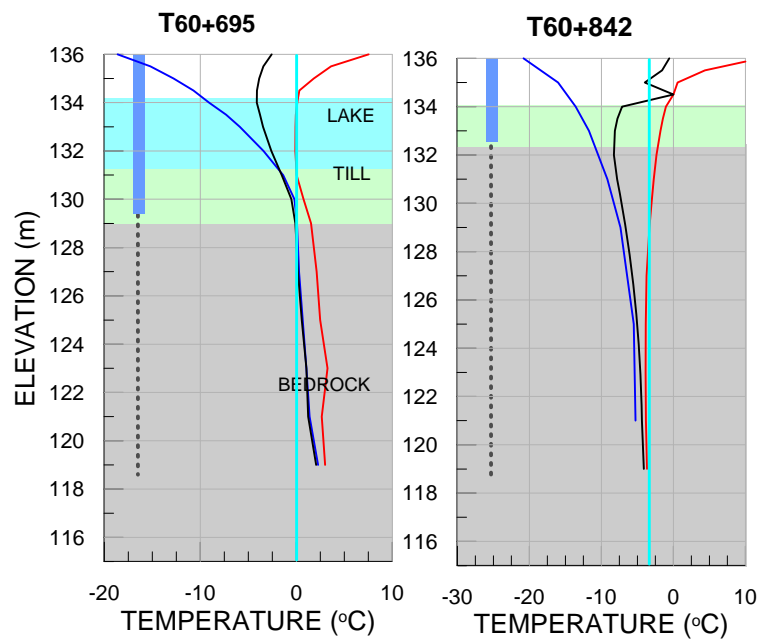
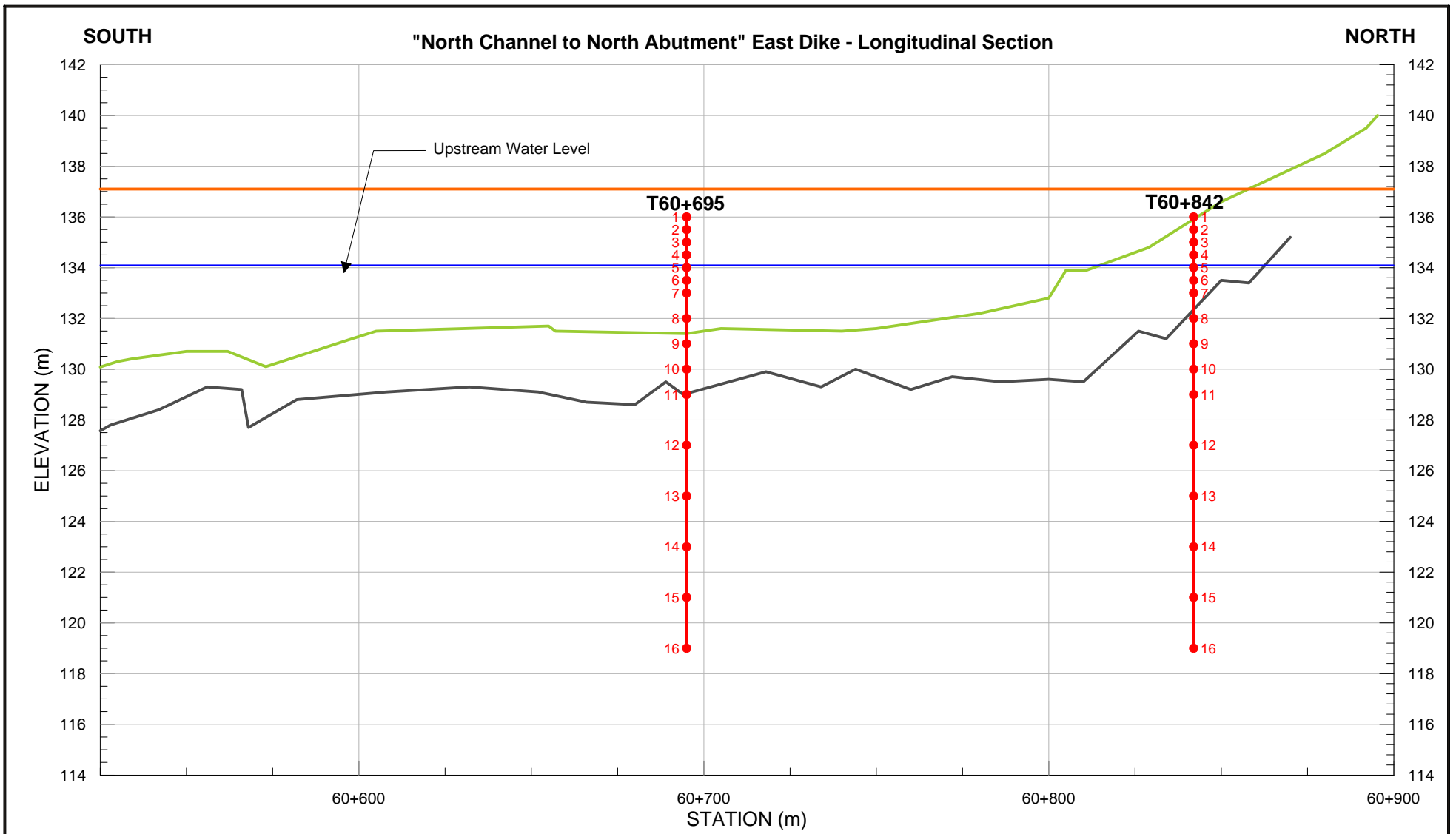

NOTES:
 1. Beads 2 and 4 on T60+842 do not seem to be working properly.

PROJECT		AGNICO EAGLE MINES LIMITED MEADOWBANK GOLD PROJECT NUNAVUT		
TITLE		BAYGOOSE DIKE 30+000 to 30+550 - TEMPERATURE DATA (Aug 31/15 to Aug 31/16)		
	PROJECT No.		PHASE No.	
	DESIGN	TD	20JAN14	SCALE AS SHOWN
	CADD	TD	20JAN14	REV.
	CHECK			
	REVIEW			FIGURE 61

T842 (60+842) NODES 1 TO 8

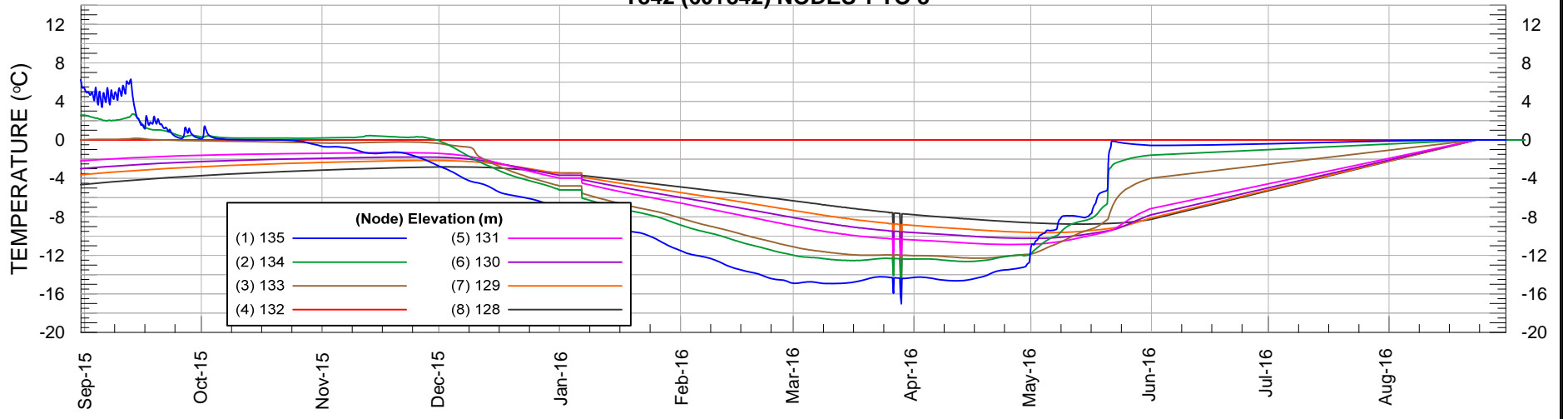

T842 (60+842) NODES 9 TO 16

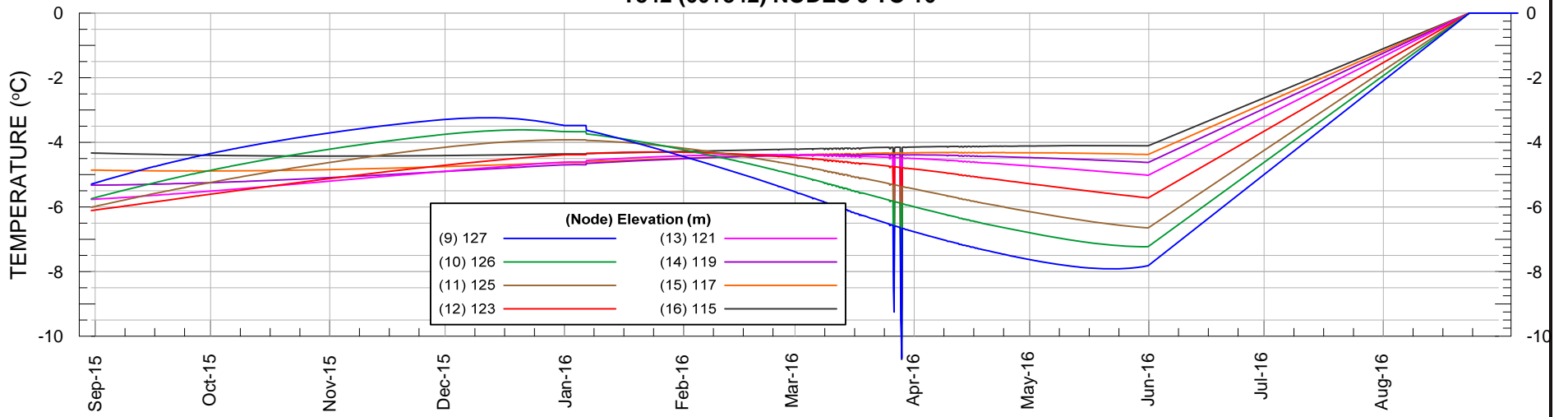

PROJECT		AGNICO EAGLE MINES LIMITED MEADOWBANK GOLD PROJECT NUNAVUT		
TITLE		EAST DIKE NODAL THERMAL TIMELINES (Aug 31/15 to Aug 31/16)		
	PROJECT No.		PHASE No.	
	DESIGN	TD	20JAN14	SCALE AS SHOWN
	CADD	TD	20JAN14	REV.
	CHECK			
	REVIEW			
				FIGURE 62

SOUTH

East Dike - Longitudinal Section - Section 60+490

NORTH

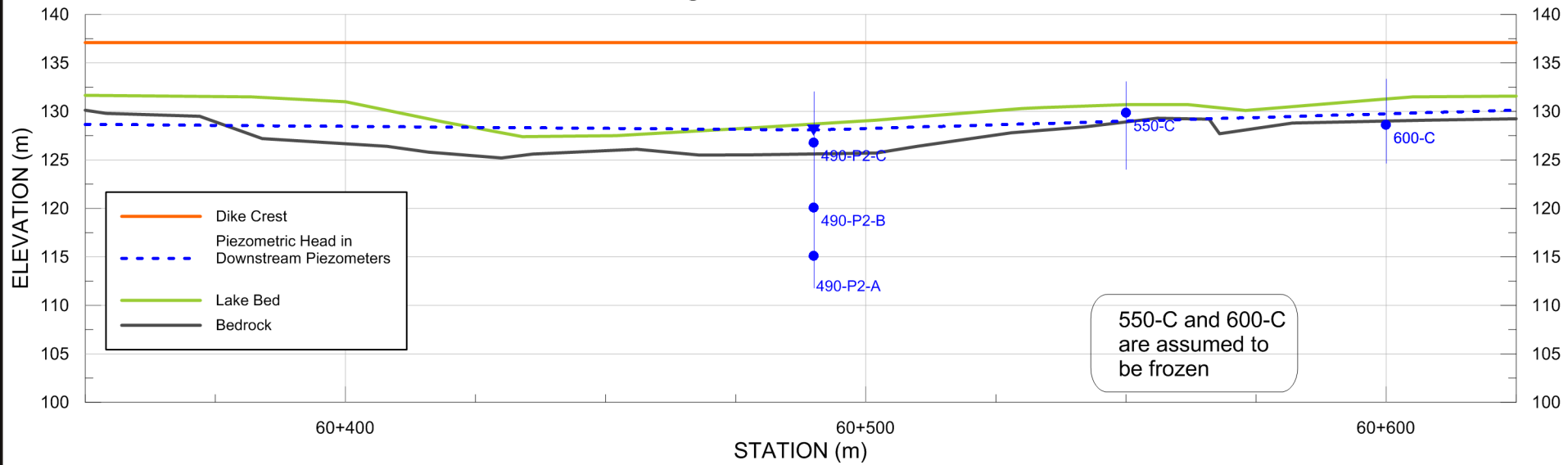

VW Piezometer - Total Head

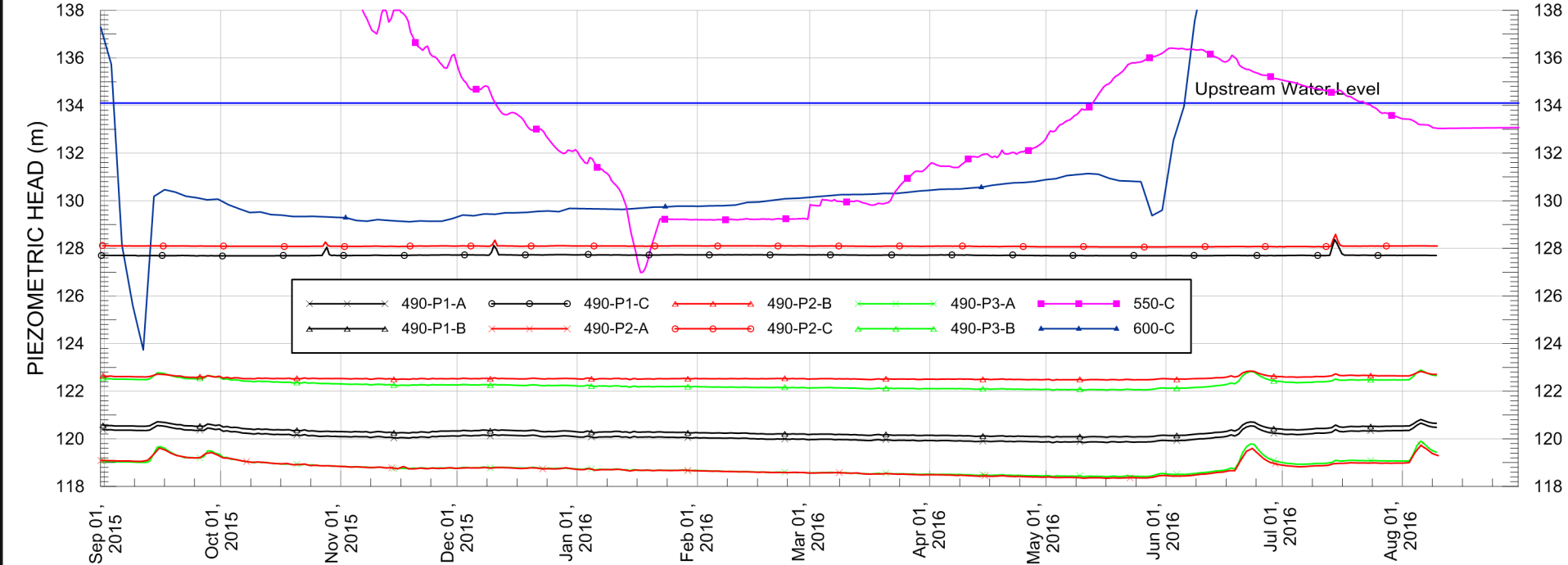

VW Piezometer - Temperature

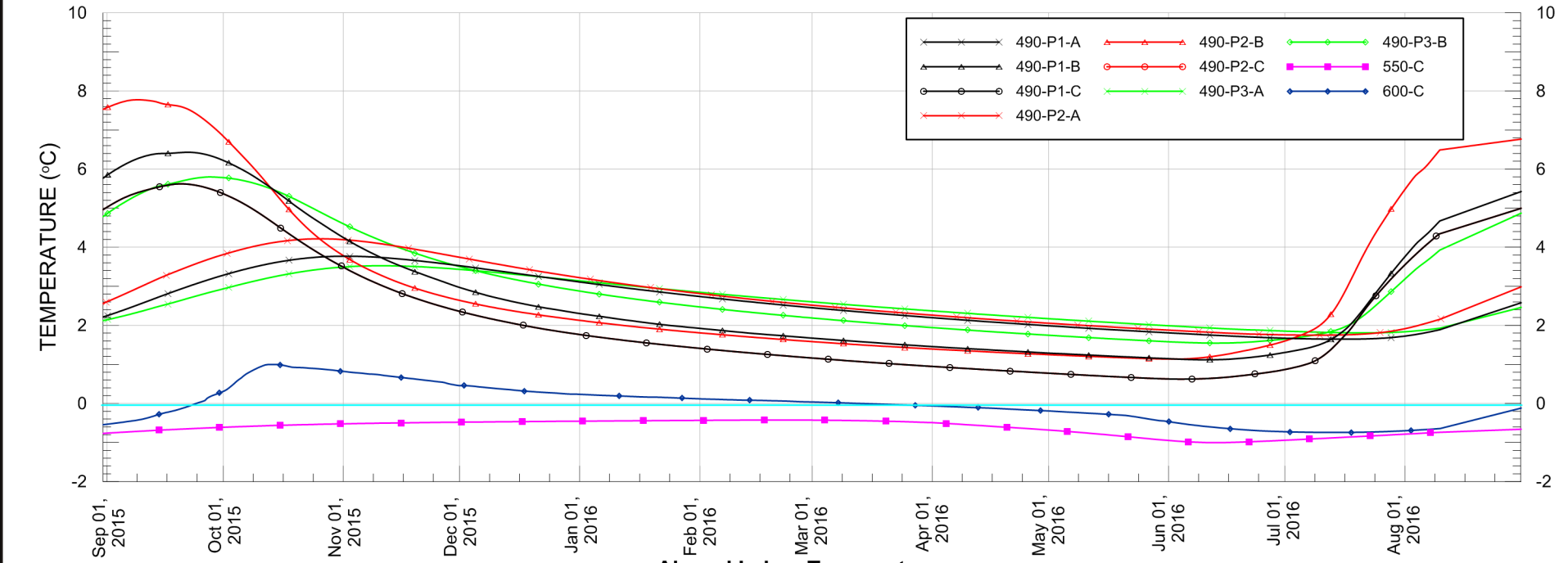

Air and Lake - Temperature

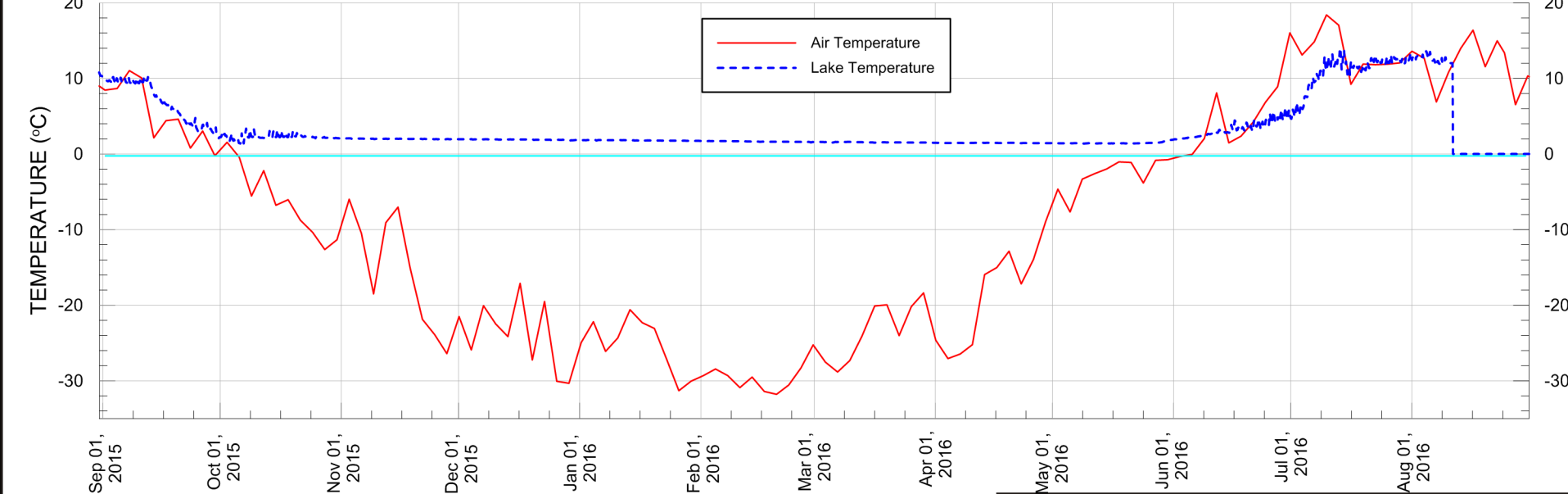

PROJECT **AGNICO EAGLE MINES LIMITED
MEADOWBANK GOLD PROJECT
NUNAVUT**

TITLE **EAST DIKE
Section 60+490 - PIEZOMETRIC DATA
(Aug 31/15 to Aug 31/16)**

	PROJECT No.		PHASE No.	
	DESIGN	TD	28AUG14	SCALE AS SHOWN
	CADD	TD	28AUG14	REV.
	CHECK	PG	28AUG14	FIGURE 48
	REVIEW			

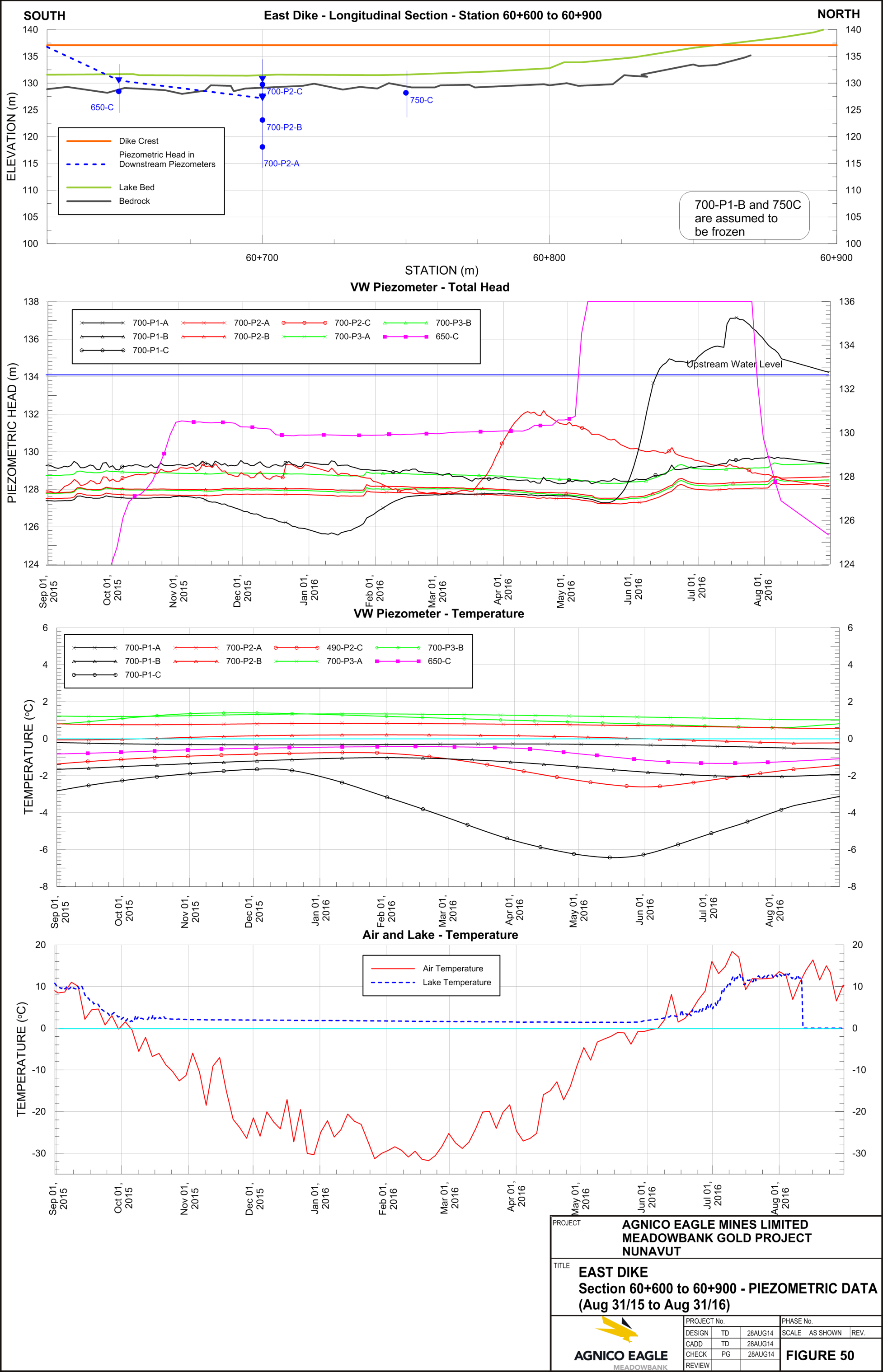

PROJECT				
AGNICO EAGLE MINES LIMITED MEADOWBANK GOLD PROJECT NUNAVUT				
TITLE				
EAST DIKE Section 60+600 to 60+900 - PIEZOMETRIC DATA (Aug 31/15 to Aug 31/16)				
 AGNICO EAGLE <small>MEADOWBANK</small>	PROJECT No.		PHASE No.	
	DESIGN	TD	28AUG14	SCALE AS SHOWN
	CADD	TD	28AUG14	REV.
	CHECK	PG	28AUG14	FIGURE 50
	REVIEW			

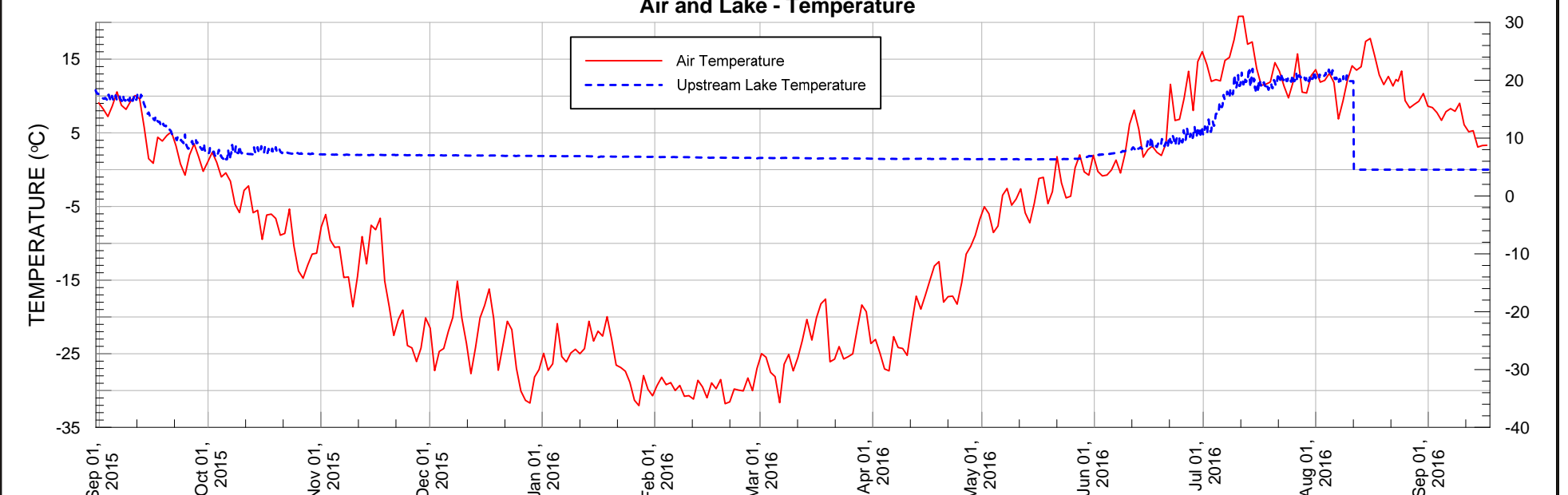
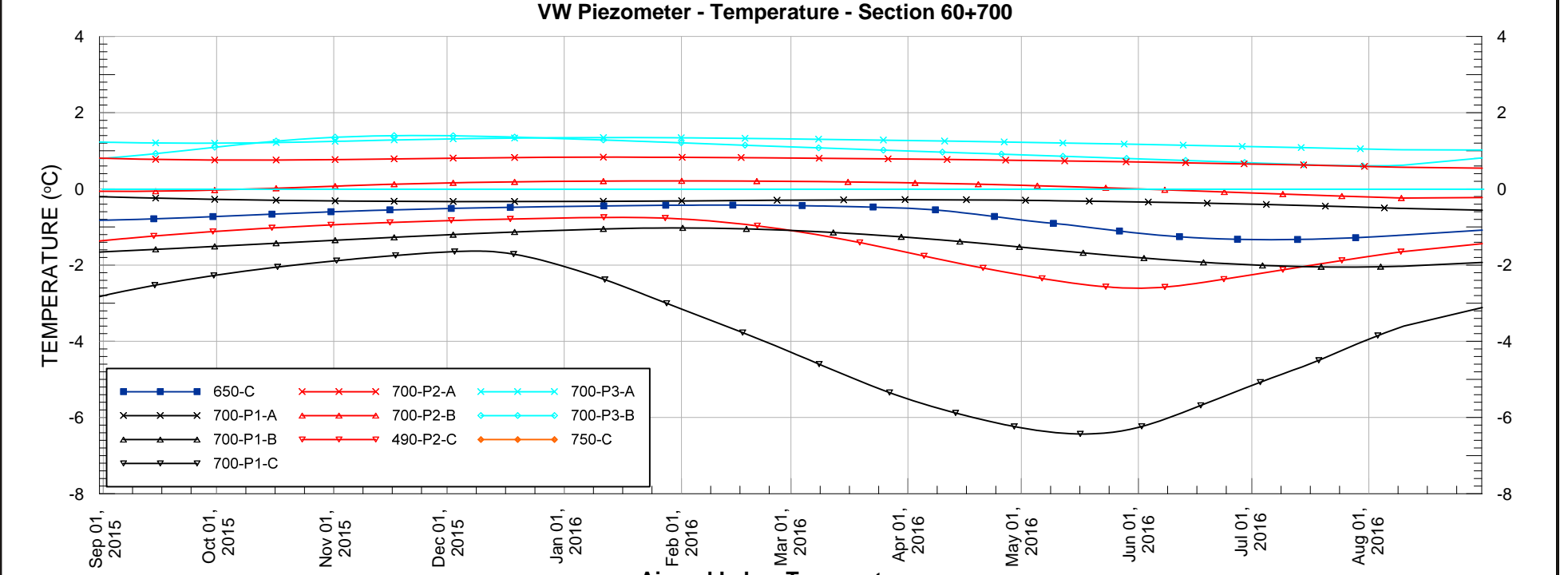
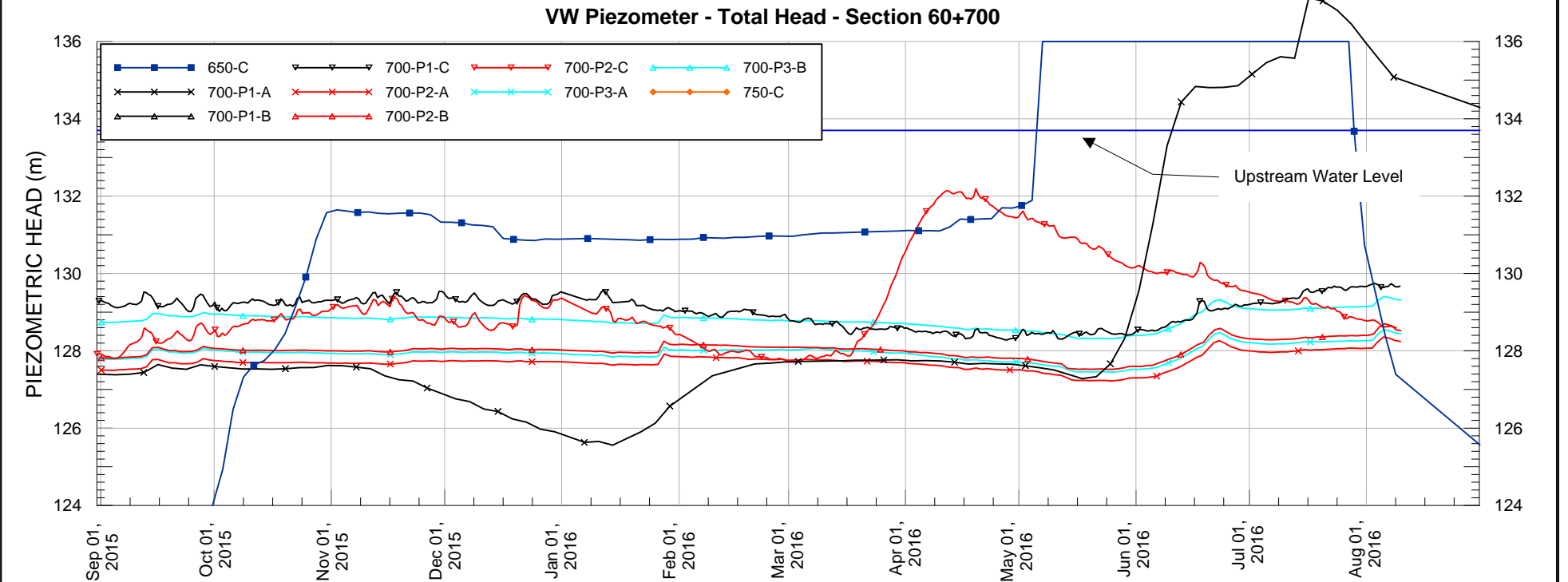
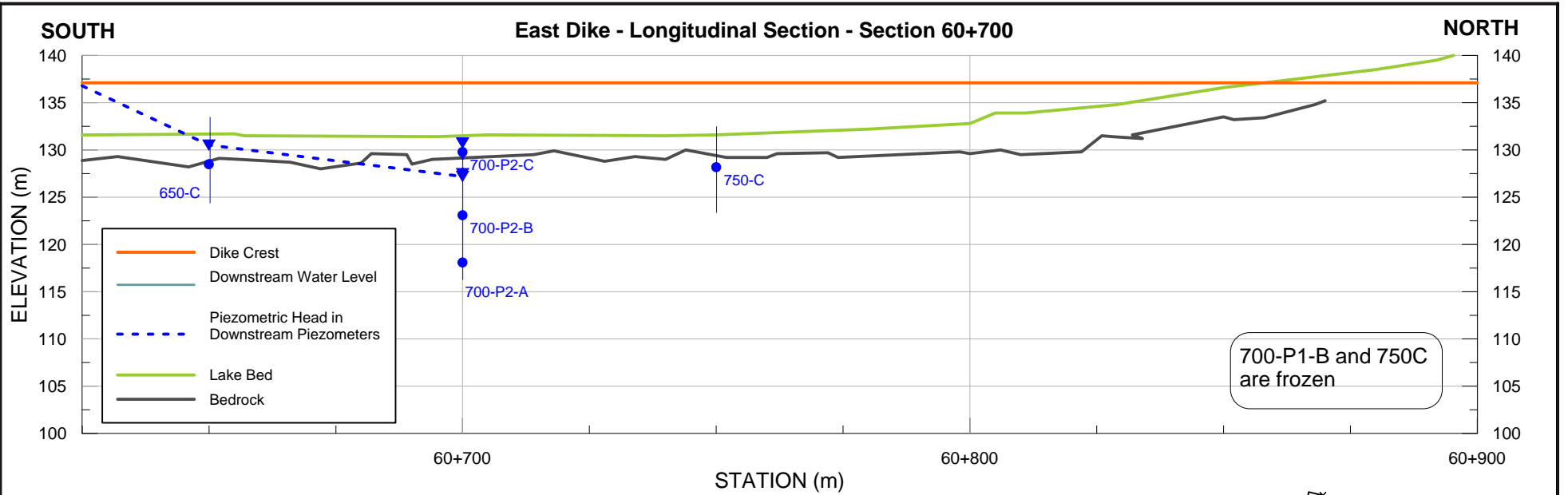

PROJECT		AGNICO EAGLE MINES LIMITED MEADOWBANK GOLD PROJECT NUNAVUT			
TITLE		EAST DIKE Section 60+700 - PIEZOMETRIC DATA (Aug 31/15 to Aug 31/16)			
	PROJECT No.	PHASE No.		FIGURE 31	
	DESIGN TD 28AUG14	SCALE	AS SHOWN		REV.
	CADD TD 28AUG14				
	CHECK PG 28AUG14				
REVIEW					

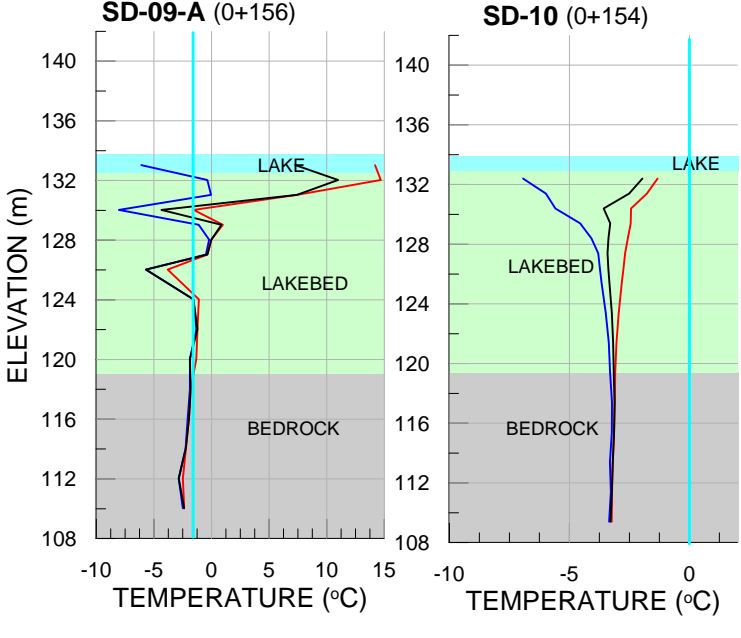
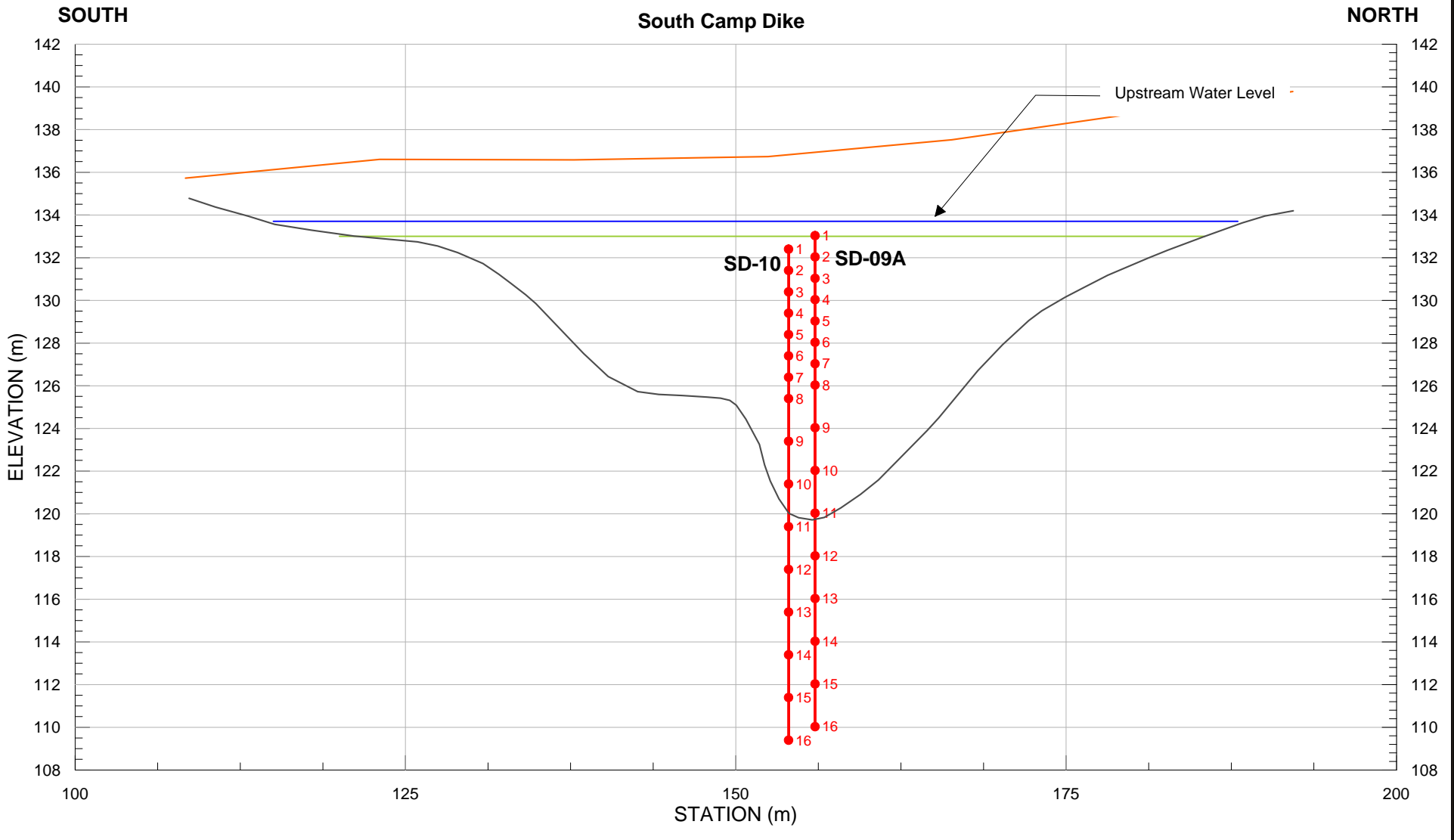

LEGEND

- Dike Crest
- Lake Bed
- Bedrock
- Lake
- Till
- Bedrock
- Thermistor with Bead Locations
- T min
- T current
- T max

PROJECT		AGNICO EAGLE MINES LIMITED MEADOWBANK GOLD PROJECT NUNAVUT		
TITLE		SOUTH CAMP DIKE TEMPERATURE DATA (Aug 31/15 to Aug 31/16)		
	PROJECT No.	PHASE No.		
	DESIGN TD 28AUG14	SCALE	AS SHOWN	REV.
	CADD TD 28AUG14	FIGURE 52		
	CHECK PG 28AUG14			
REVIEW				

SD-09A

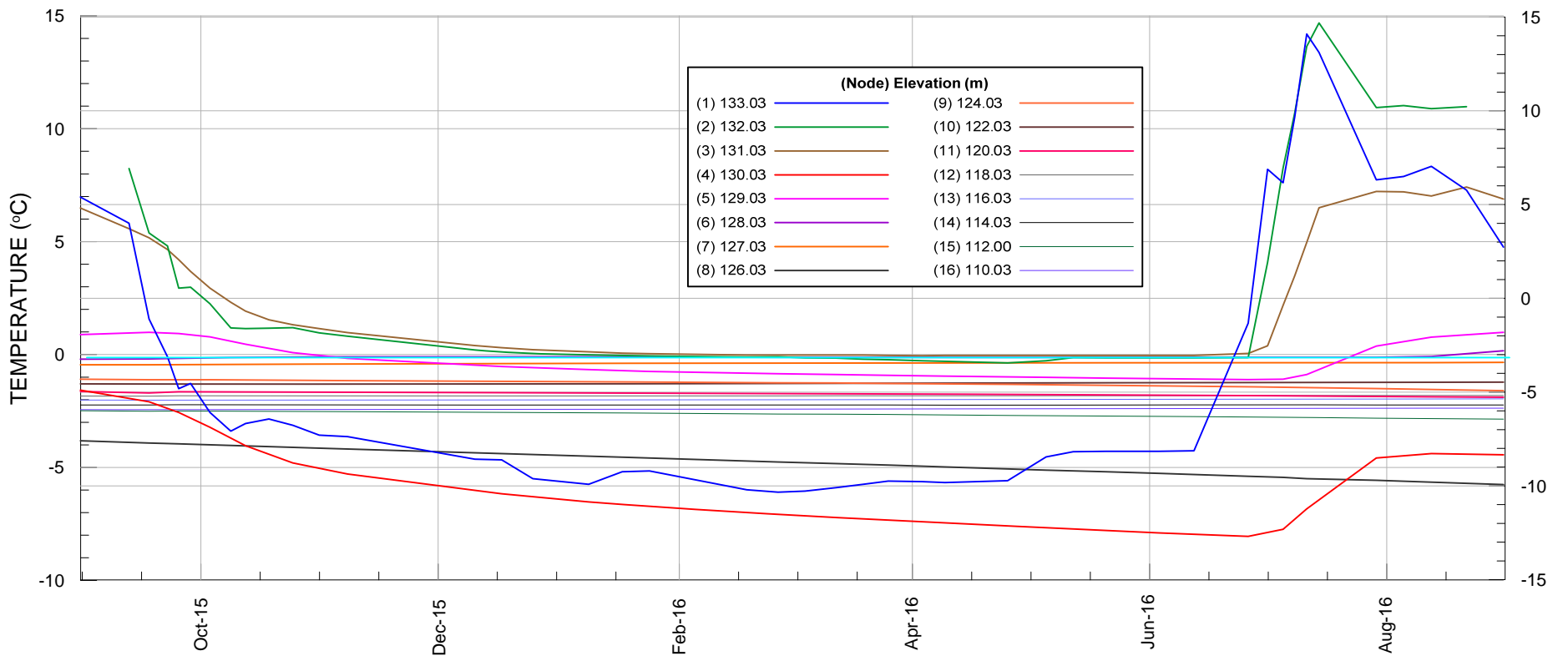

SD-10

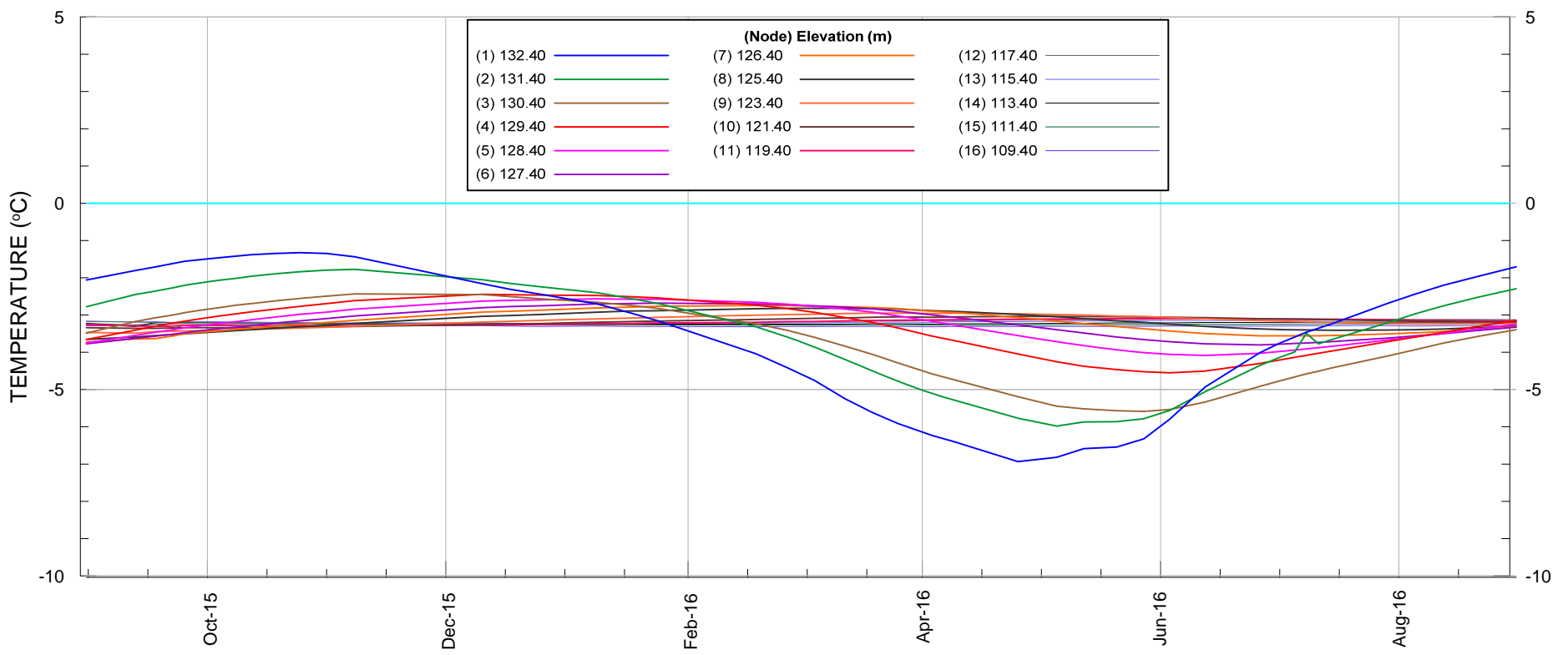

PROJECT		AGNICO EAGLE MINES LIMITED MEADOWBANK GOLD PROJECT NUNAVUT		
TITLE		SOUTH CAMP DIKE NODAL THERMAL TIMELINES (Aug 31/15 to Aug 31/16)		
	PROJECT No.		PHASE No.	
	DESIGN	TD	28AUG14	SCALE AS SHOWN
	CADD	TD	28AUG14	REV.
	CHECK	PG	28AUG14	FIGURE 53
REVIEW				

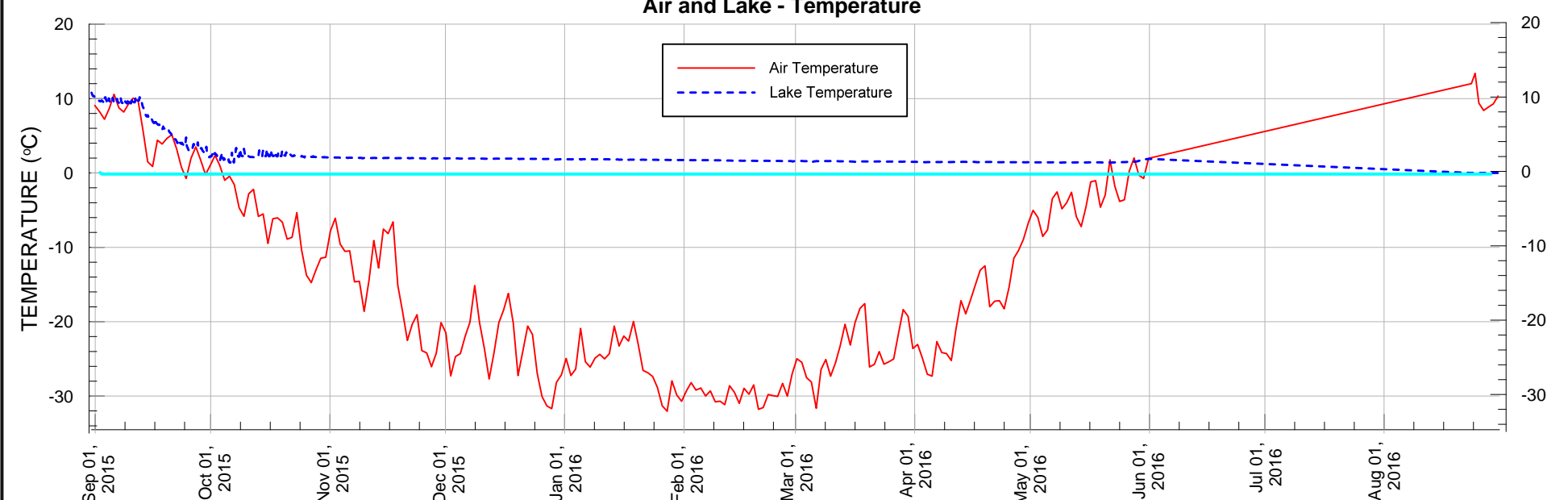
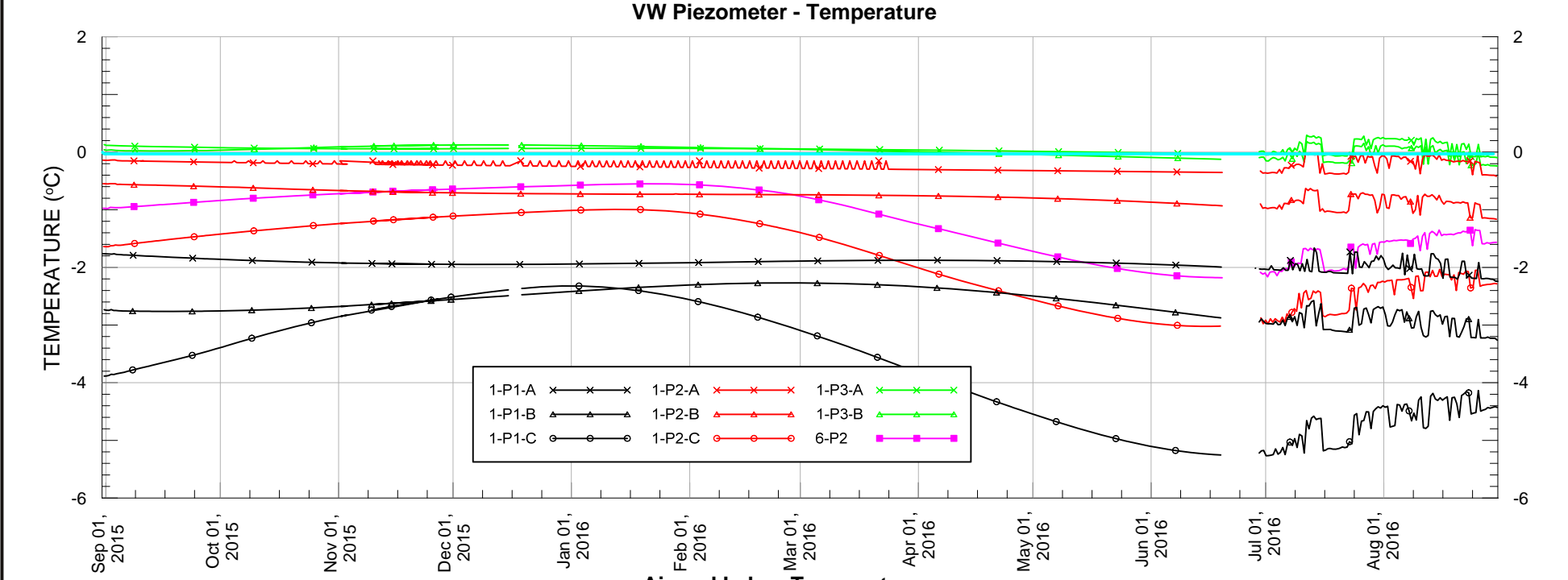
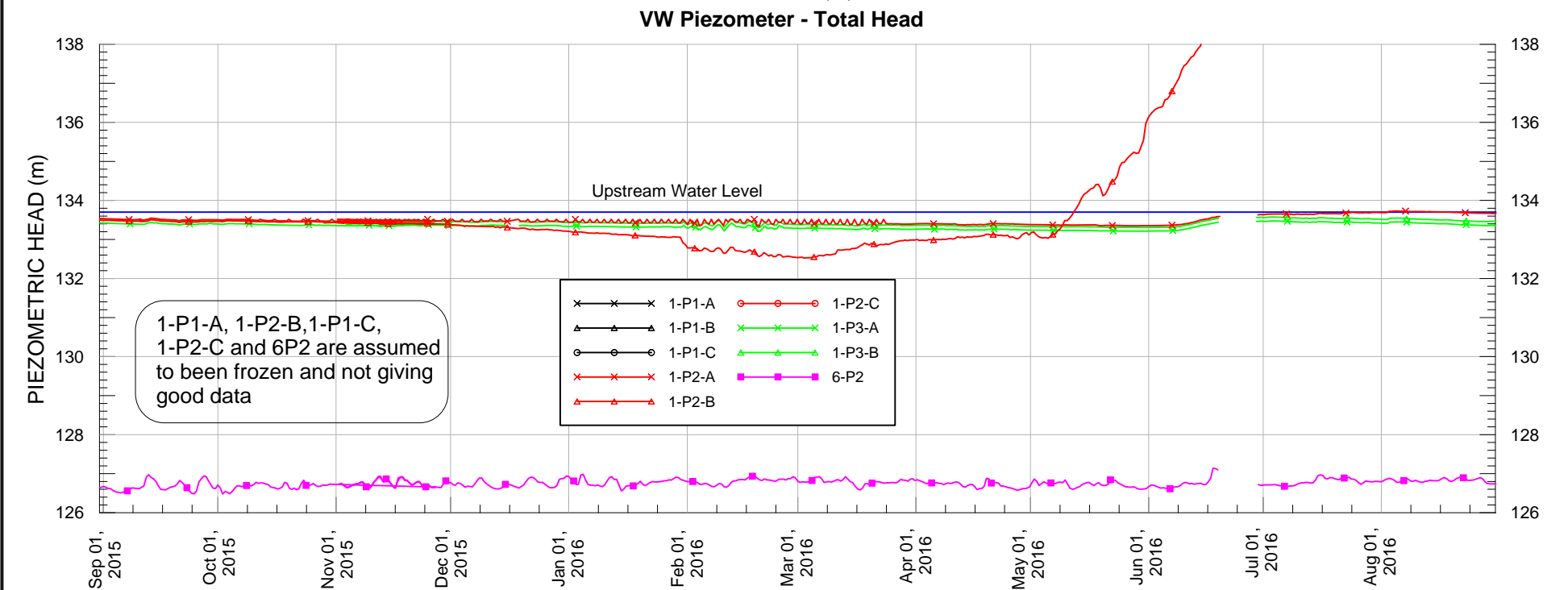
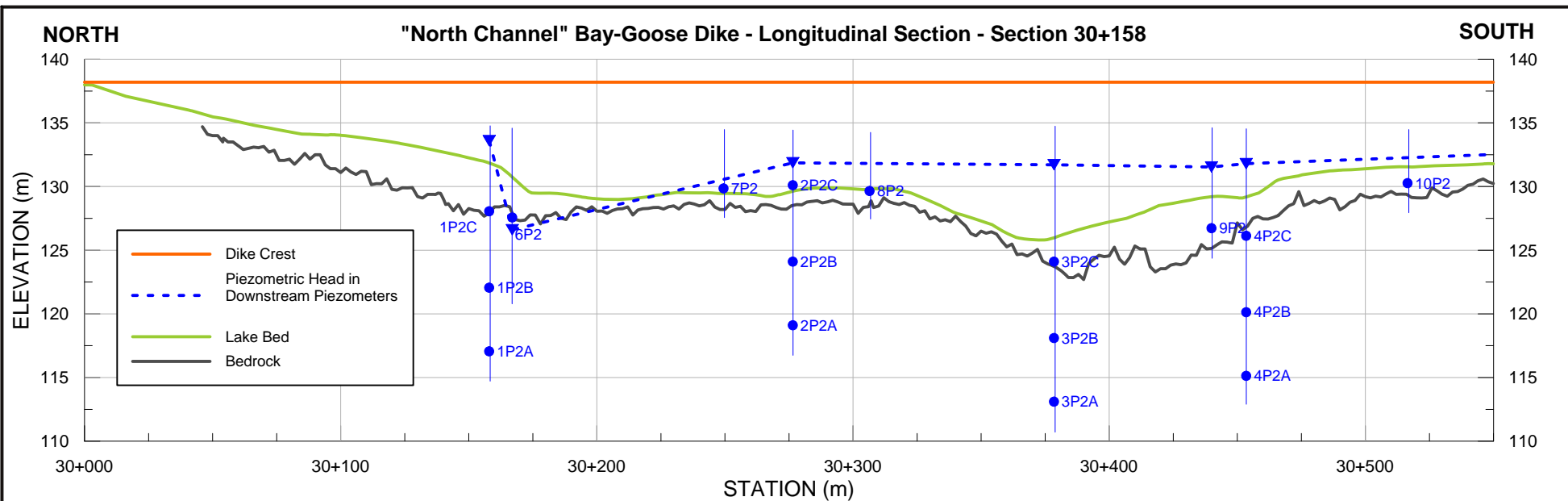

PROJECT		AGNICO EAGLE MINES LIMITED MEADOWBANK GOLD PROJECT NUNAVUT		
TITLE		BAYGOOSE DIKE Section 30+158 - PIEZOMETRIC DATA (Aug 31/15 to Aug 31/16)		
	PROJECT No.	PHASE No.		FIGURE 1
	DESIGN TD	30/8/14	SCALE AS SHOWN	
	CADD PG	30/8/14	REV.	
	CHECK PG	31/8/14		
REVIEW				

STATION 30+158

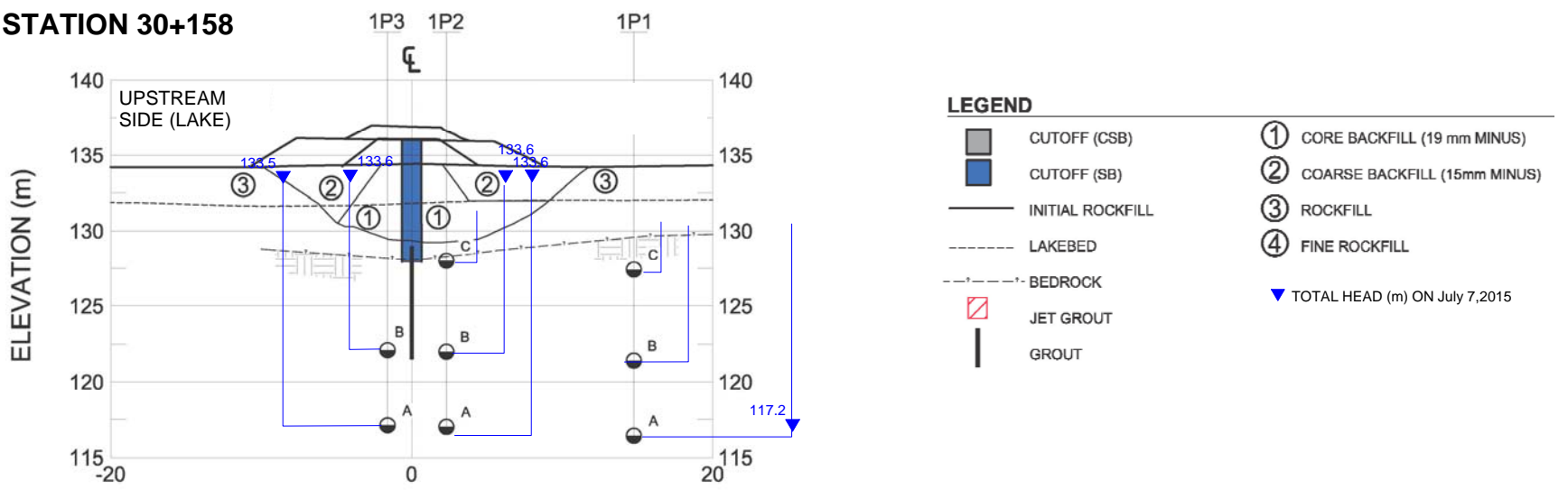

VW Piezometer - Total Head

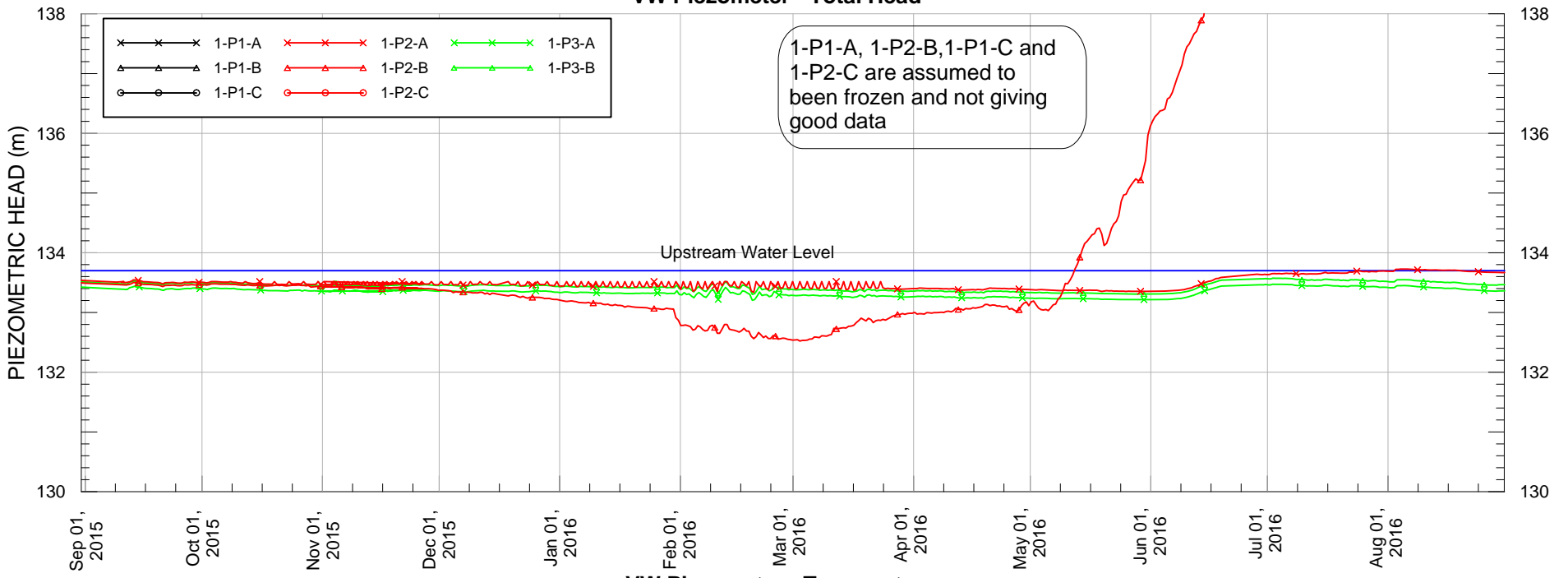

VW Piezometer - Temperature

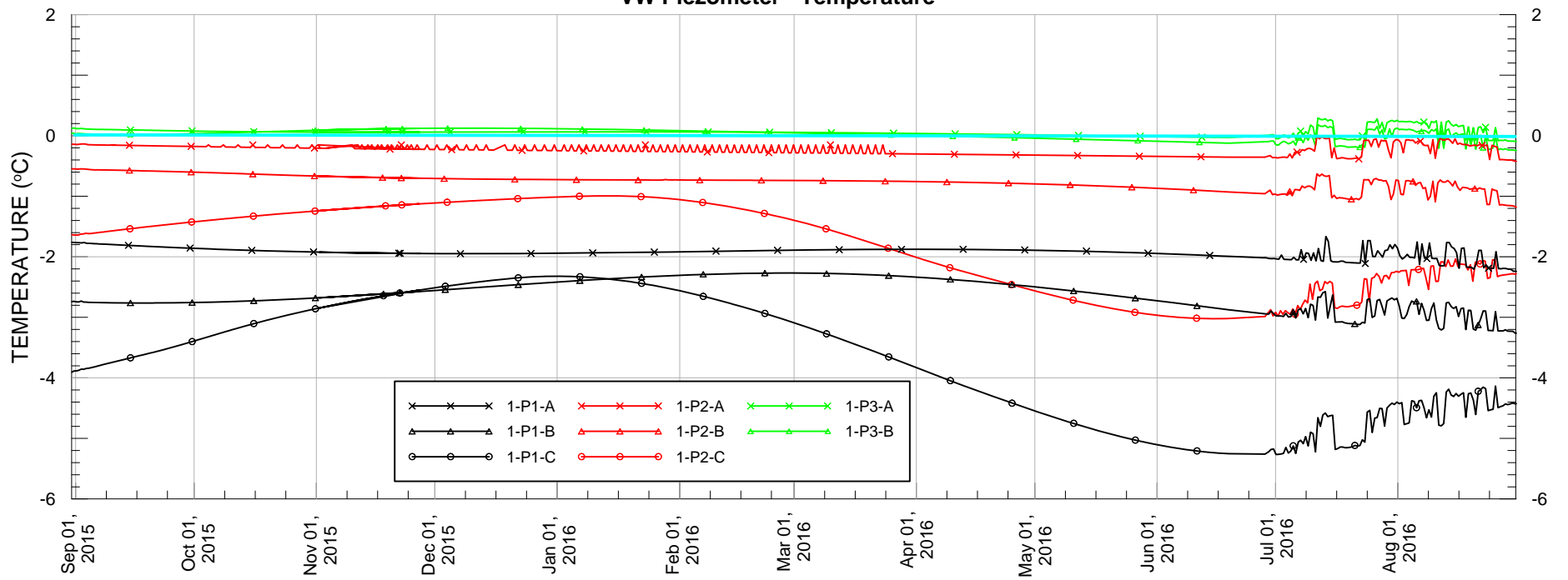

Air and Lake - Temperature

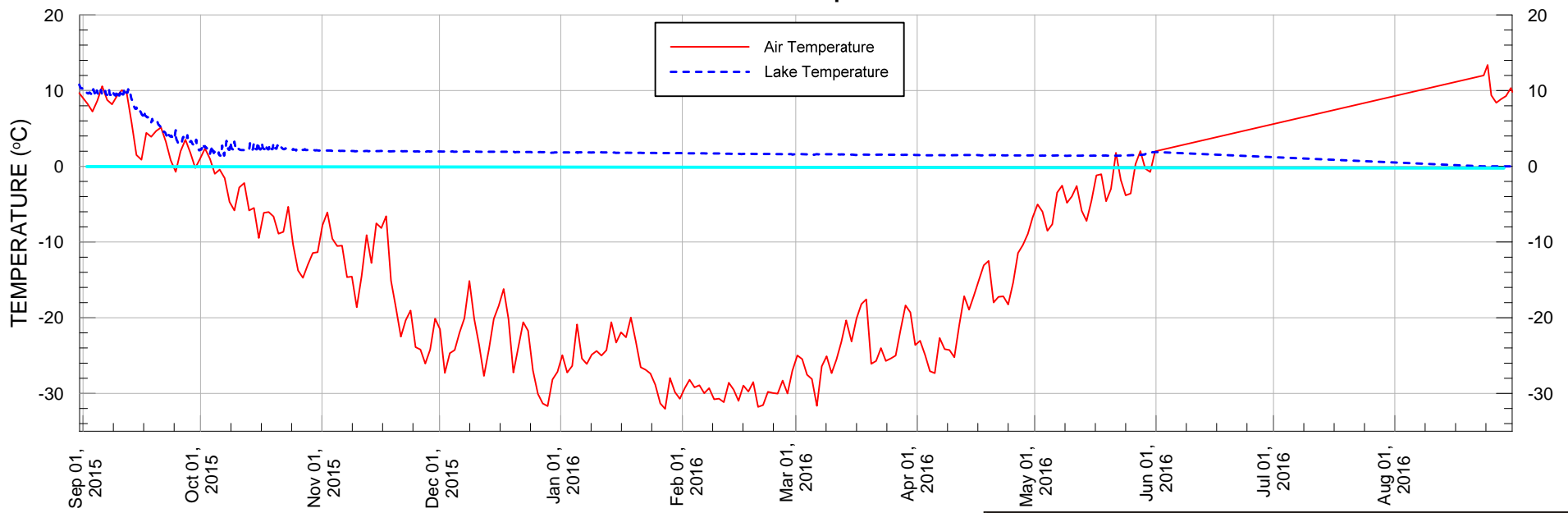

PROJECT				AGNICO EAGLE MINES LIMITED MEADOWBANK GOLD PROJECT NUNAVUT			
TITLE				BAYGOOSE DIKE - SECTION 30+158 PIEZOMETRIC DATA (Aug 31/15 to Aug 31/16)			
PROJECT No.		PHASE No.		DESIGN		SCALE AS SHOWN	
31AUG14		REV.		TD		31AUG14	
CHECK		PG		28AUG14		FIGURE 2	
REVIEW							

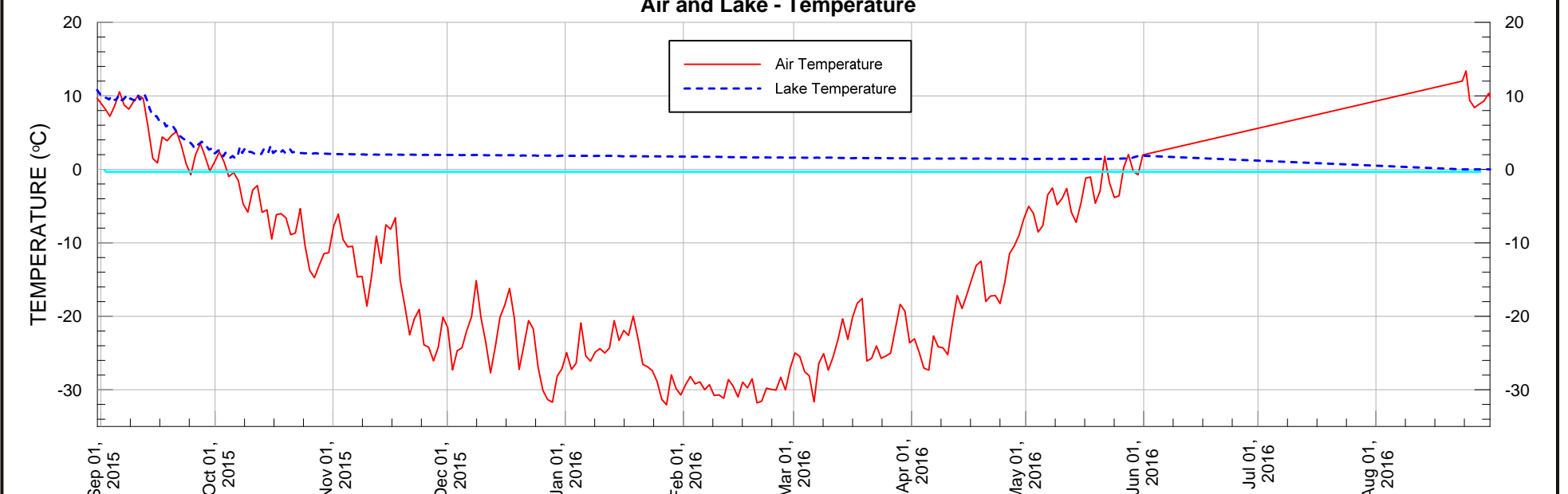
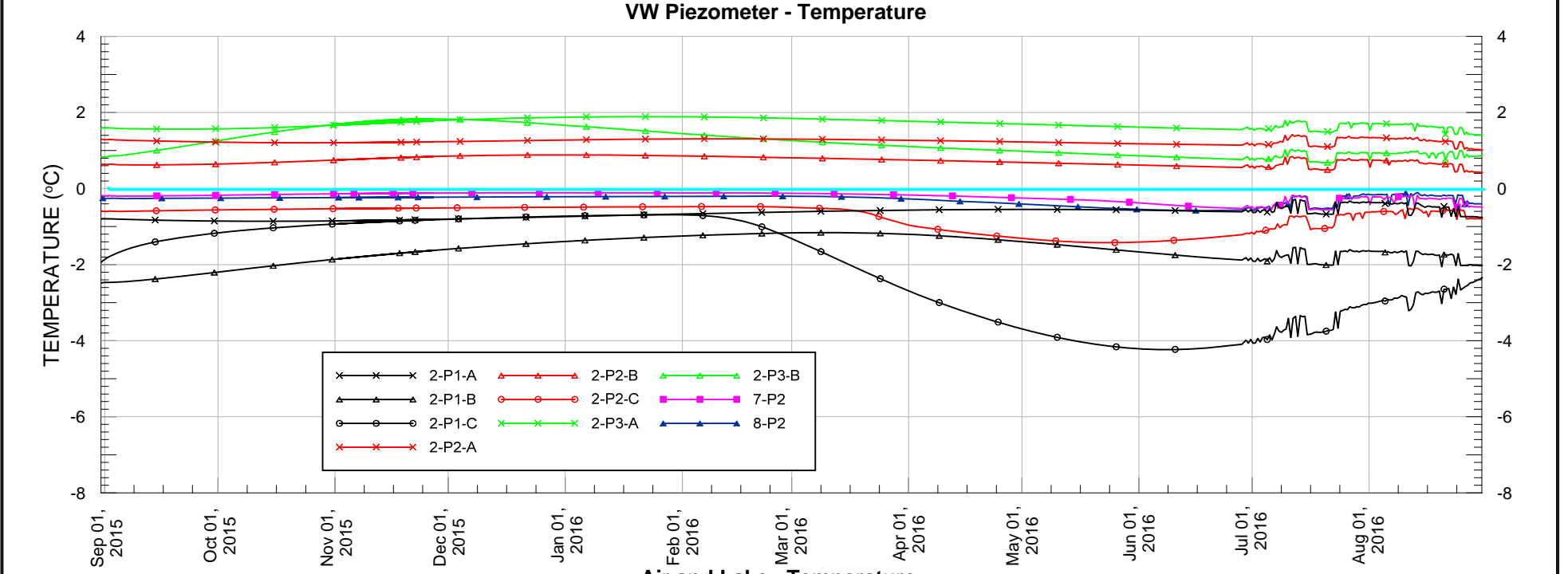
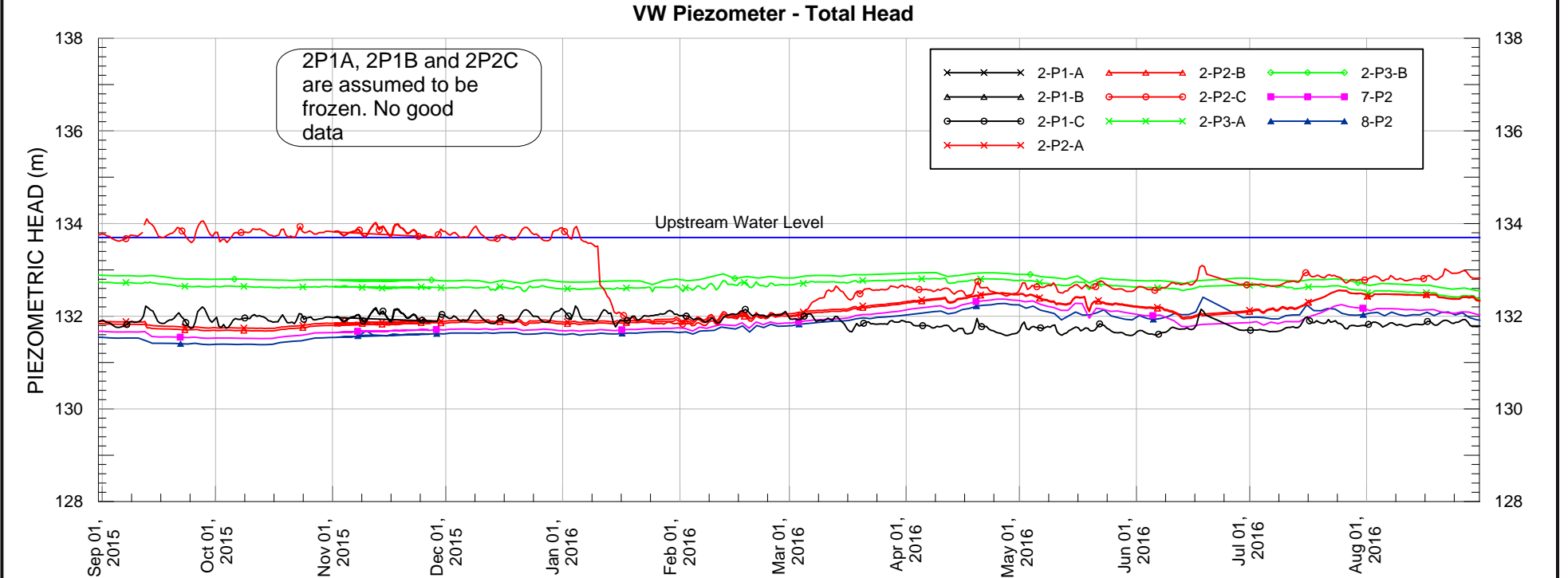
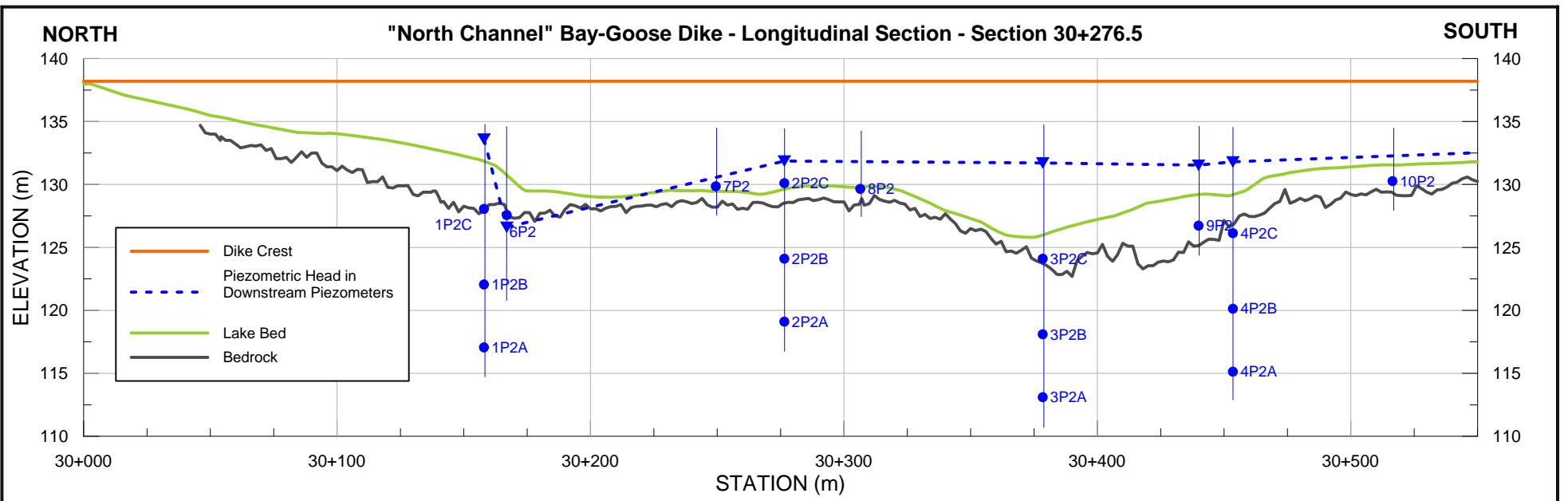

PROJECT			
AGNICO EAGLE MINES LIMITED MEADOWBANK GOLD PROJECT NUNAVUT			
TITLE			
BAYGOOSE DIKE Section 30+276.5 - PIEZOMETRIC DATA (Aug 31/15 to Aug 31/16)			
	PROJECT No.		PHASE No.
	DESIGN	TD 28AUG14	SCALE AS SHOWN
	CADD	TD 28AUG14	REV.
	CHECK	PG 28AUG14	FIGURE 3
REVIEW			

STATION 30+276.5

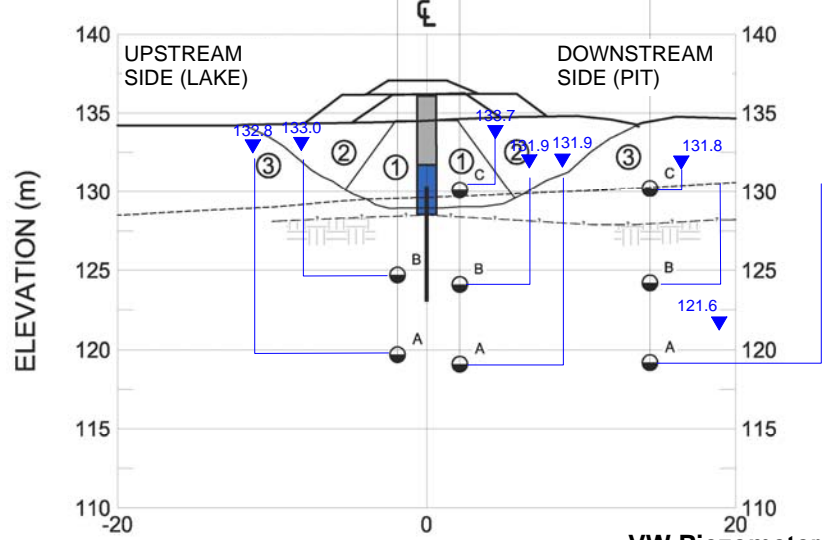

LEGEND

- CUTOFF (CSB)
- CUTOFF (SB)
- INITIAL ROCKFILL
- LAKEBED
- BEDROCK
- JET GROUT
- GROUT
- CORE BACKFILL (19 mm MINUS)
- COARSE BACKFILL (15mm MINUS)
- ROCKFILL
- FINE ROCKFILL
- TOTAL HEAD (m) ON July 7, 2015

VW Piezometer - Total Head

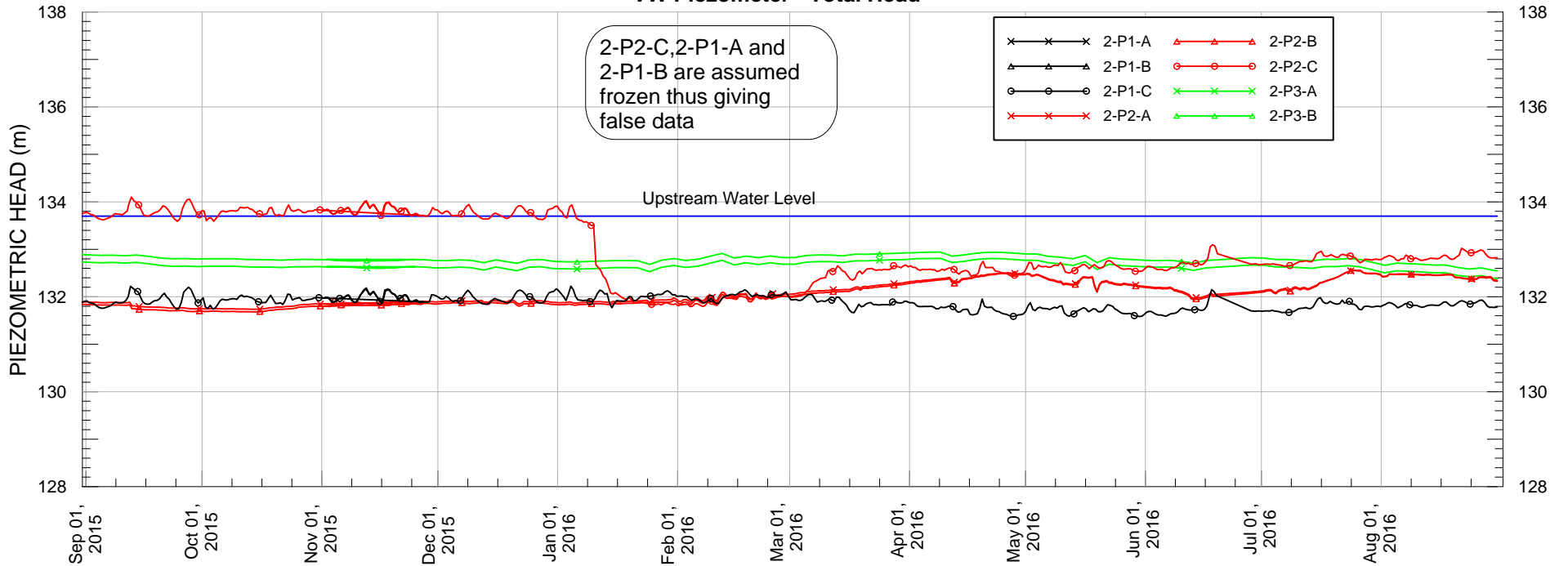

VW Piezometer - Temperature

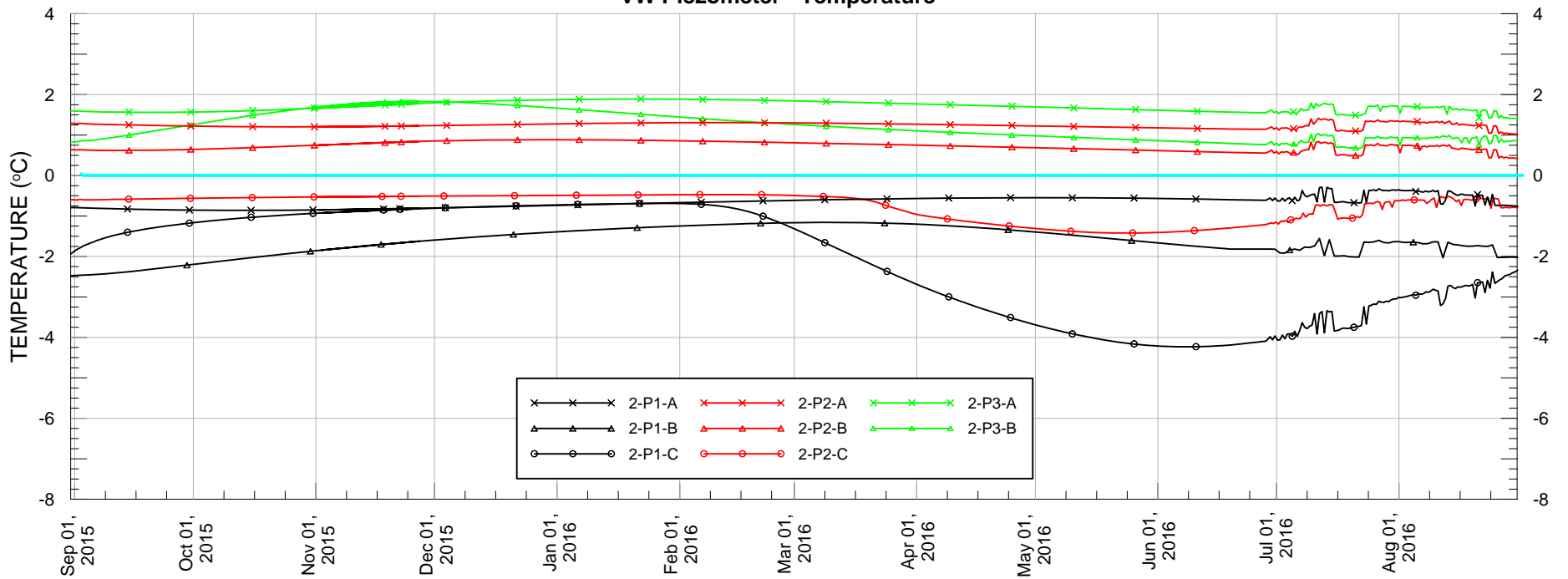

Air and Lake - Temperature

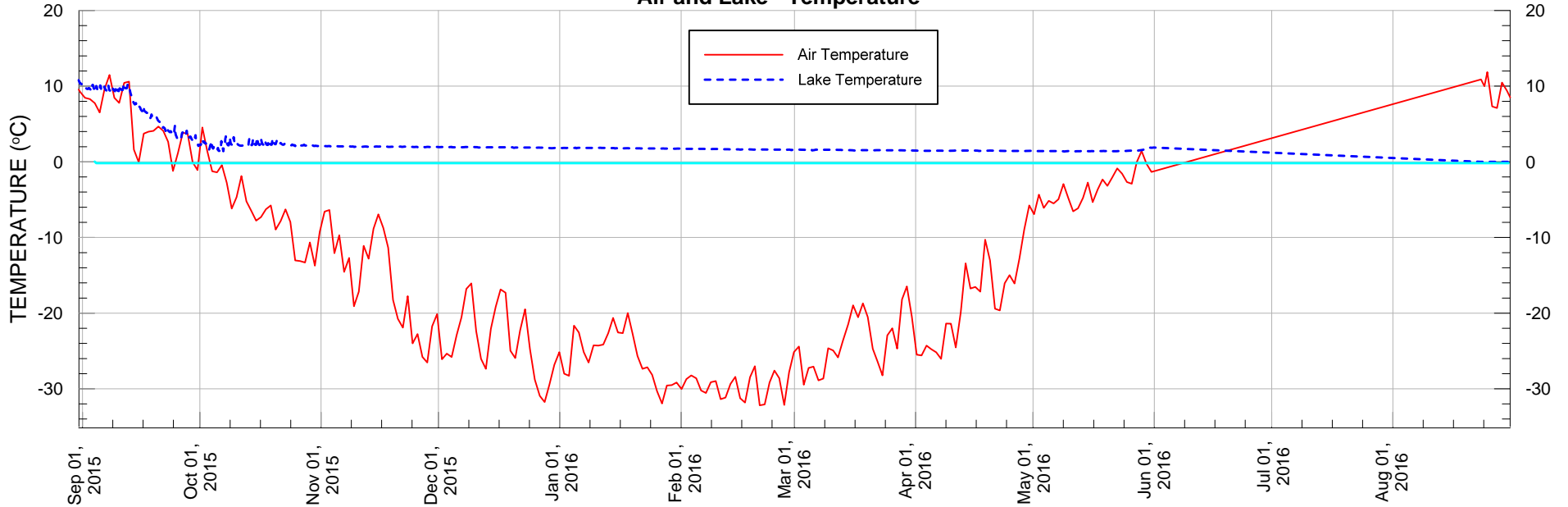

PROJECT		AGNICO EAGLE MINES LIMITED MEADOWBANK GOLD PROJECT NUNAVUT		
TITLE		BAY GOOSE DIKE - SECTION 30+276.5 PIEZOMETRIC DATA (Aug 31/15 to Aug 31/16)		
	PROJECT No.	PHASE No.		
	DESIGN TD 28AUG14	SCALE AS SHOWN	REV.	
	CADD TD 28AUG14	Figure 4		
	CHECK PG 28AUG14			
REVIEW				

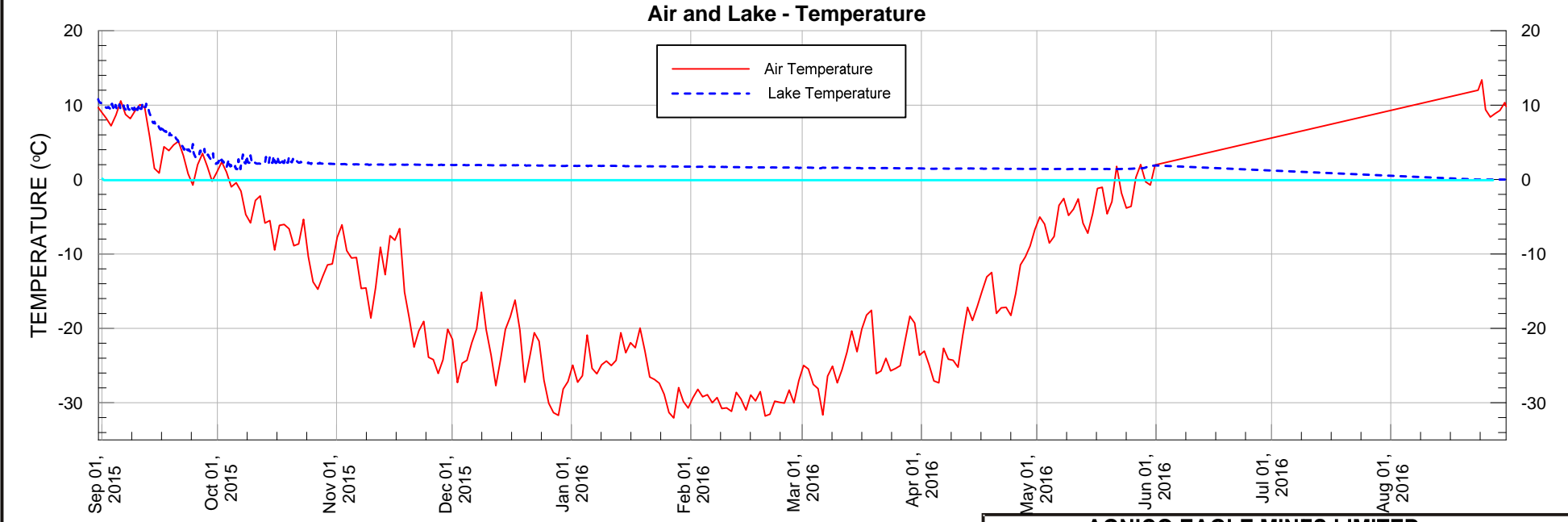
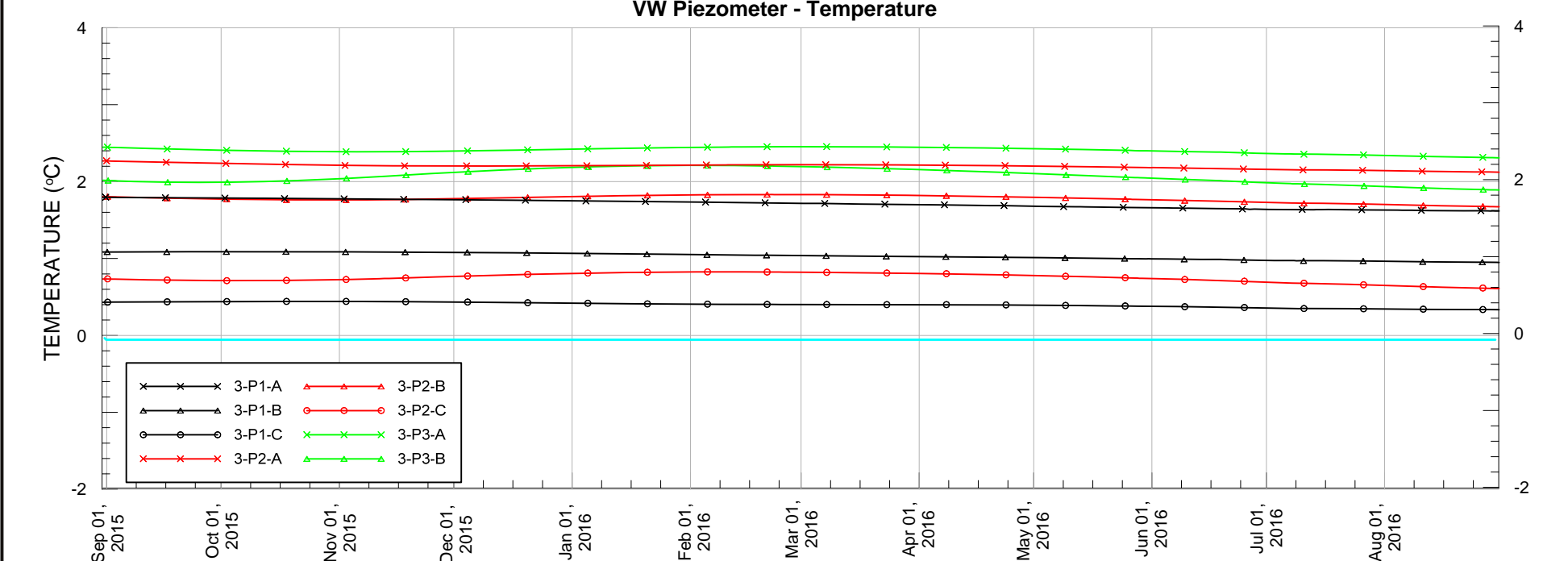
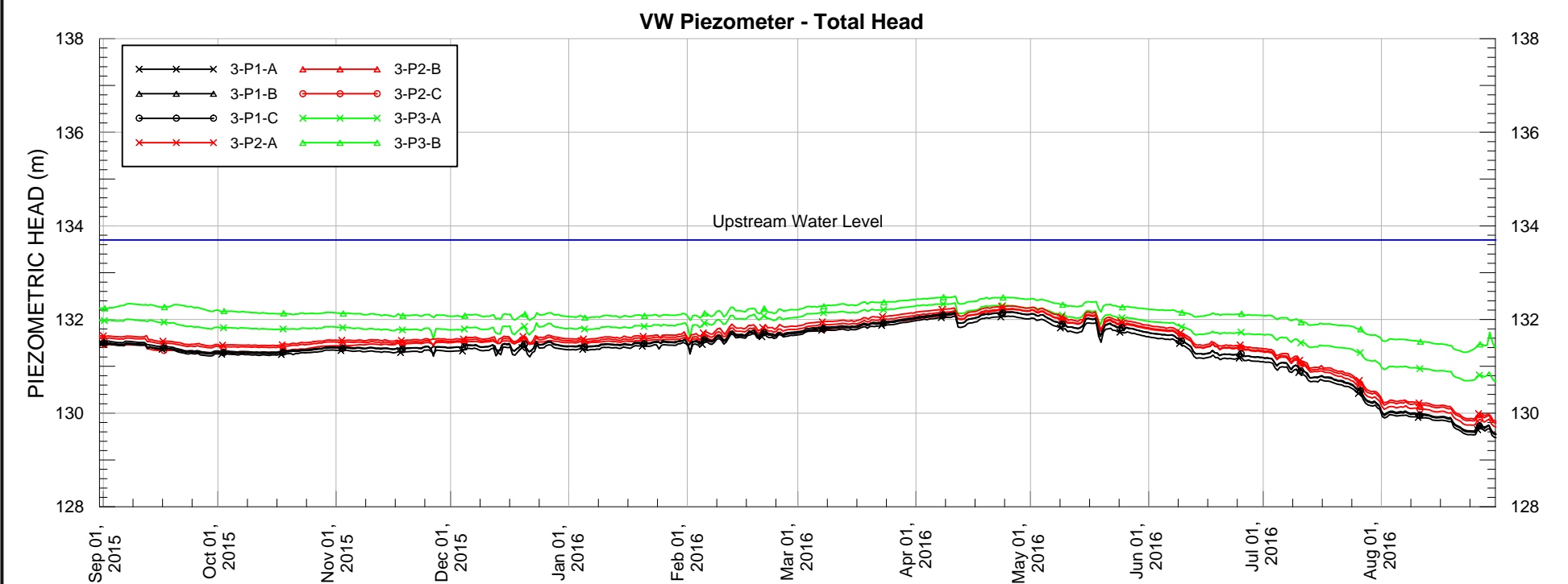
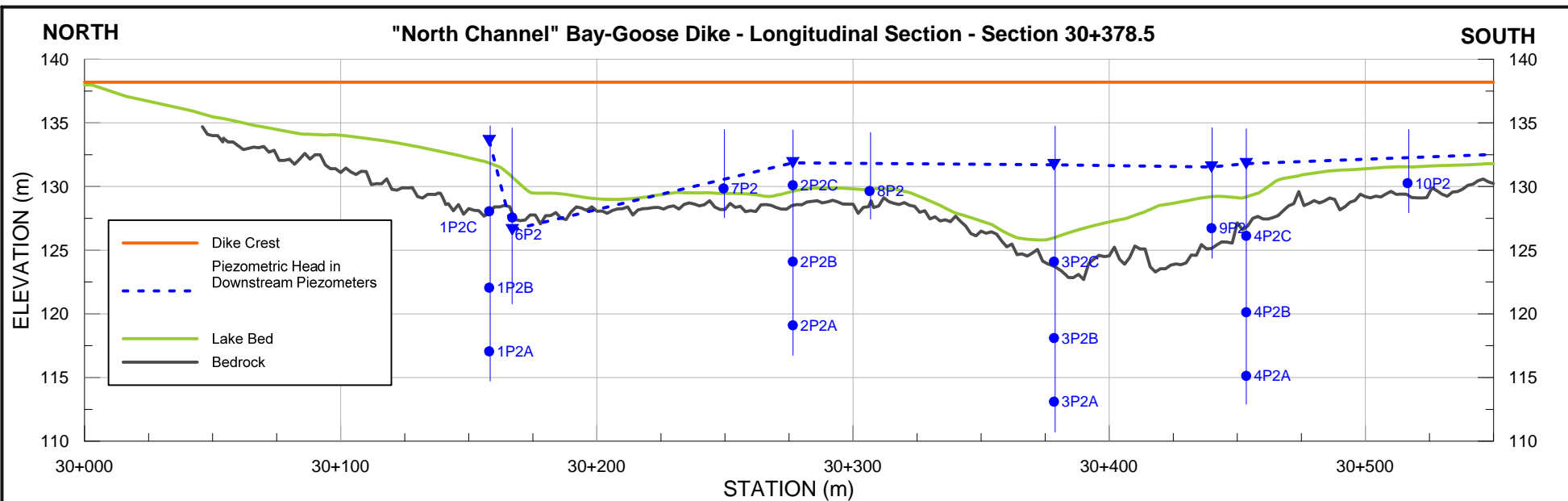

PROJECT			
AGNICO EAGLE MINES LIMITED MEADOWBANK GOLD PROJECT NUNAVUT			
TITLE			
BAYGOOSE DIKE Section 30+378.5 - PIEZOMETRIC DATA (Aug 31/15 to Aug 31/16)			
	PROJECT No.		PHASE No.
	DESIGN	TD	28AUG14
	CADD	TD	28AUG14
	CHECK	PG	28AUG14
REVIEW			SCALE AS SHOWN
			FIGURE 5

STATION 30+378.5

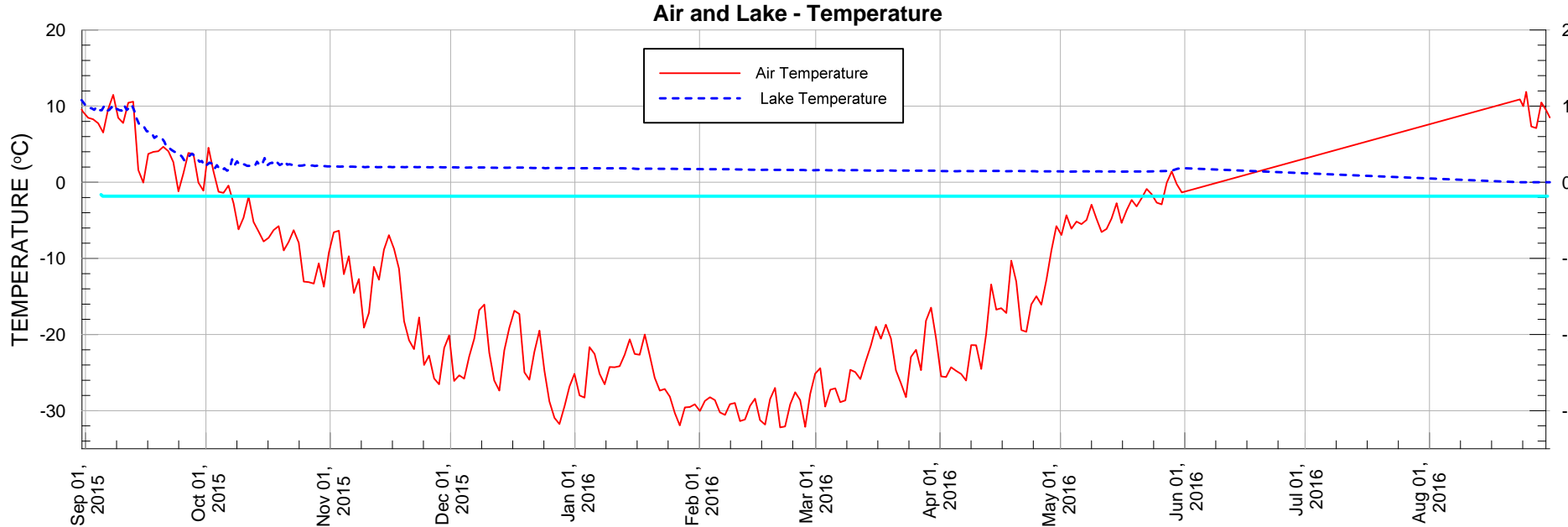
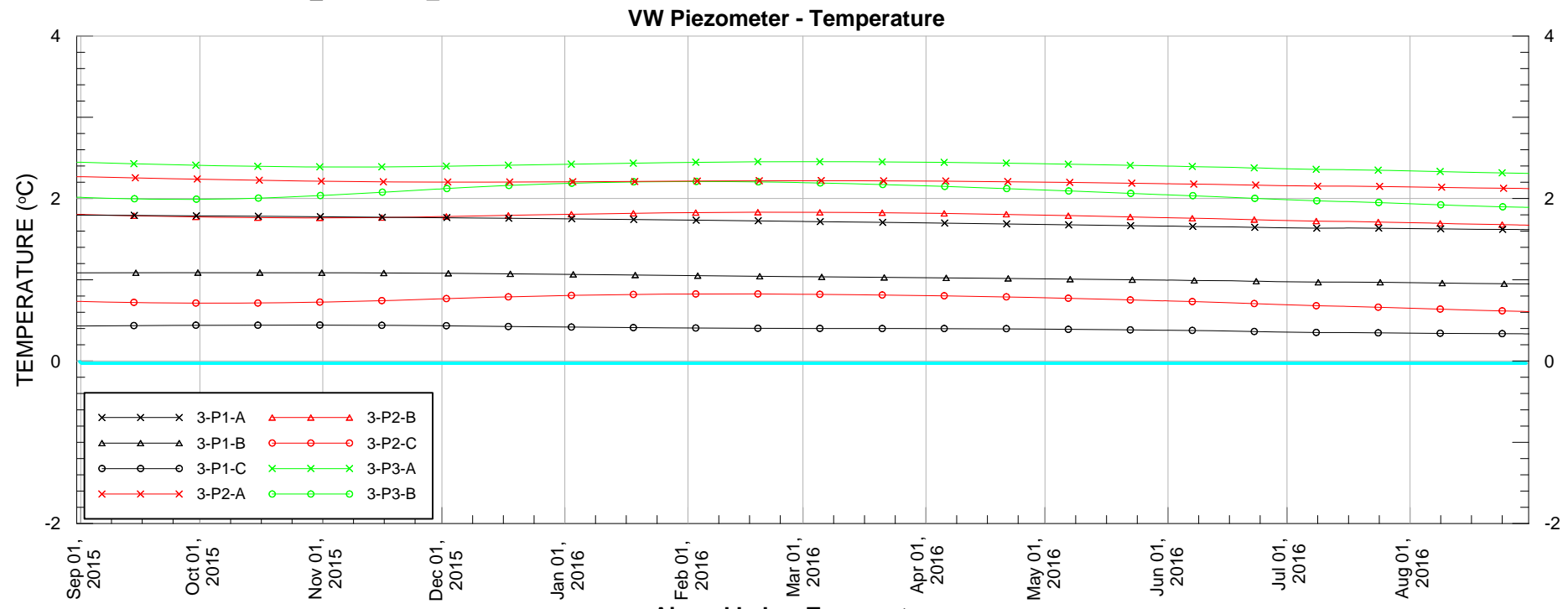
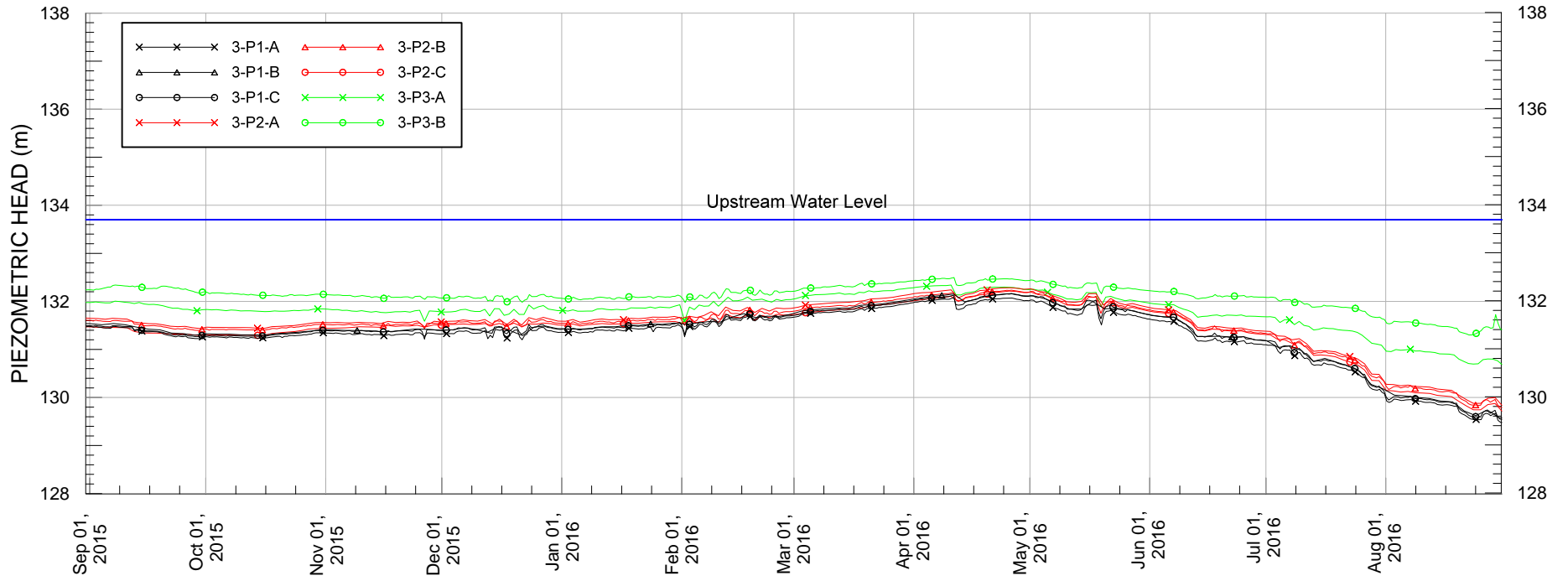
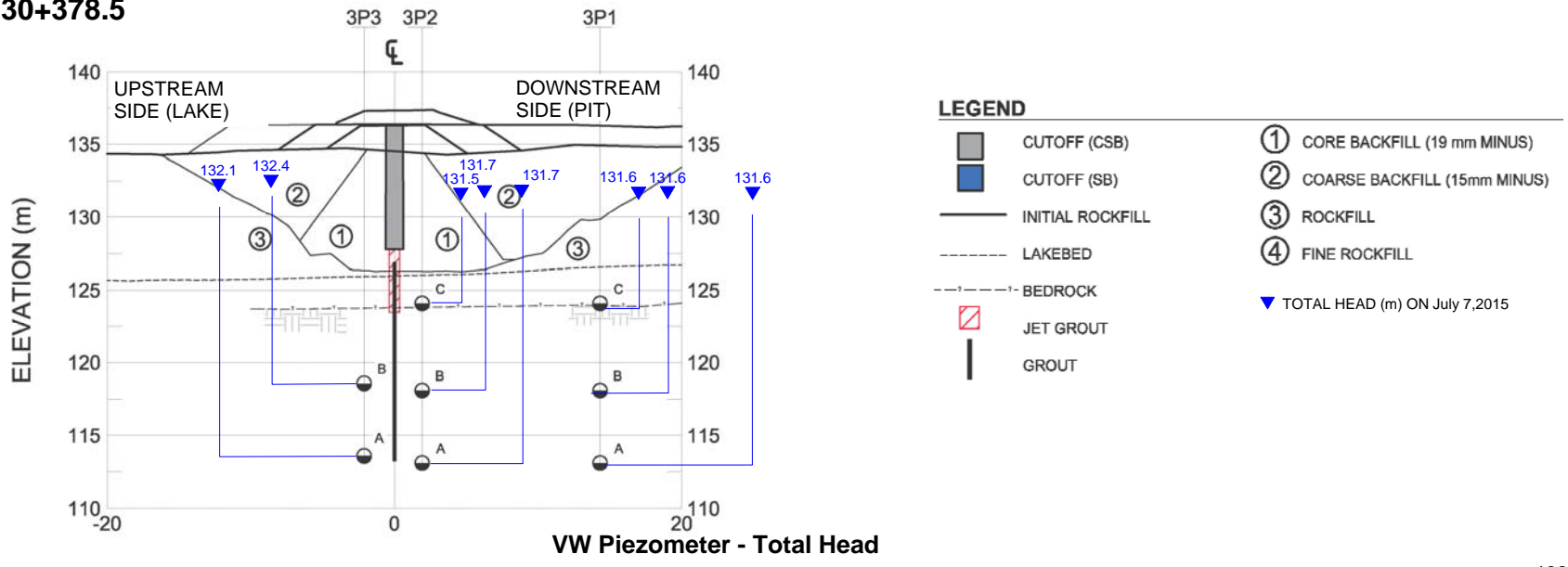

PROJECT				AGNICO EAGLE MINES LIMITED MEADOWBANK GOLD PROJECT NUNAVUT			
TITLE				BAYGOOSE DIKE - SECTION 30+378.5 PIEZOMETRIC DATA (Aug 31/15 to Aug 31/16)			
PROJECT No.		PHASE No.		DESIGN		SCALE	
CADD		TD		28AUG16		AS SHOWN	
CHECK		TD		28AUG16		REV.	
REVIEW		PG		28AUG16		FIGURE 6	

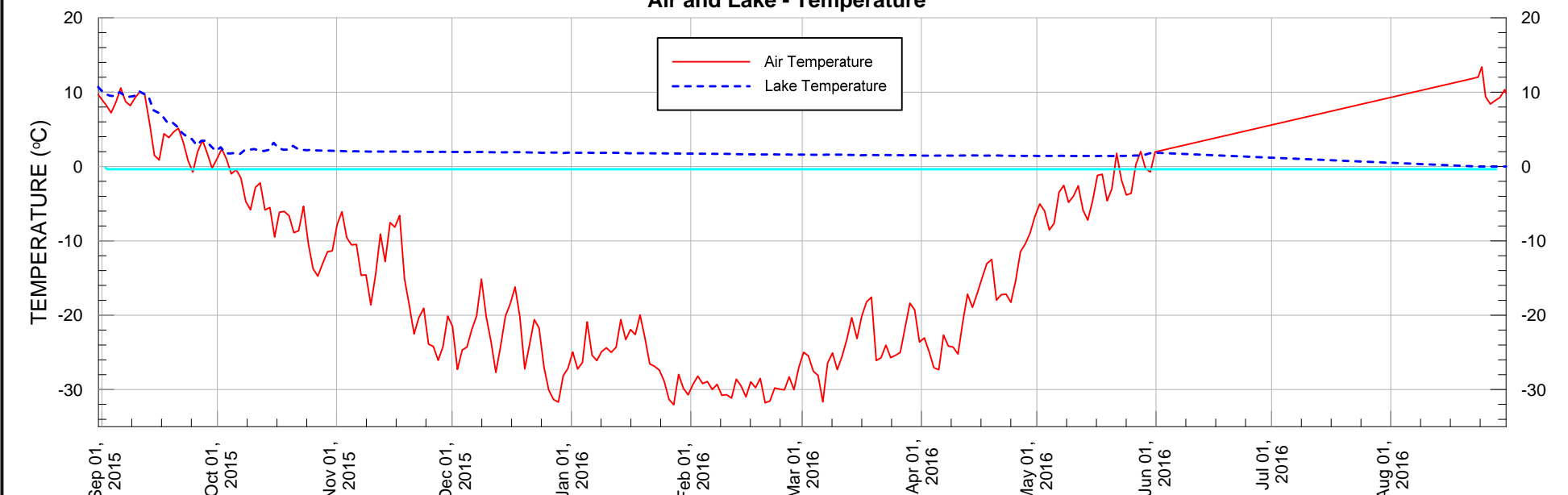
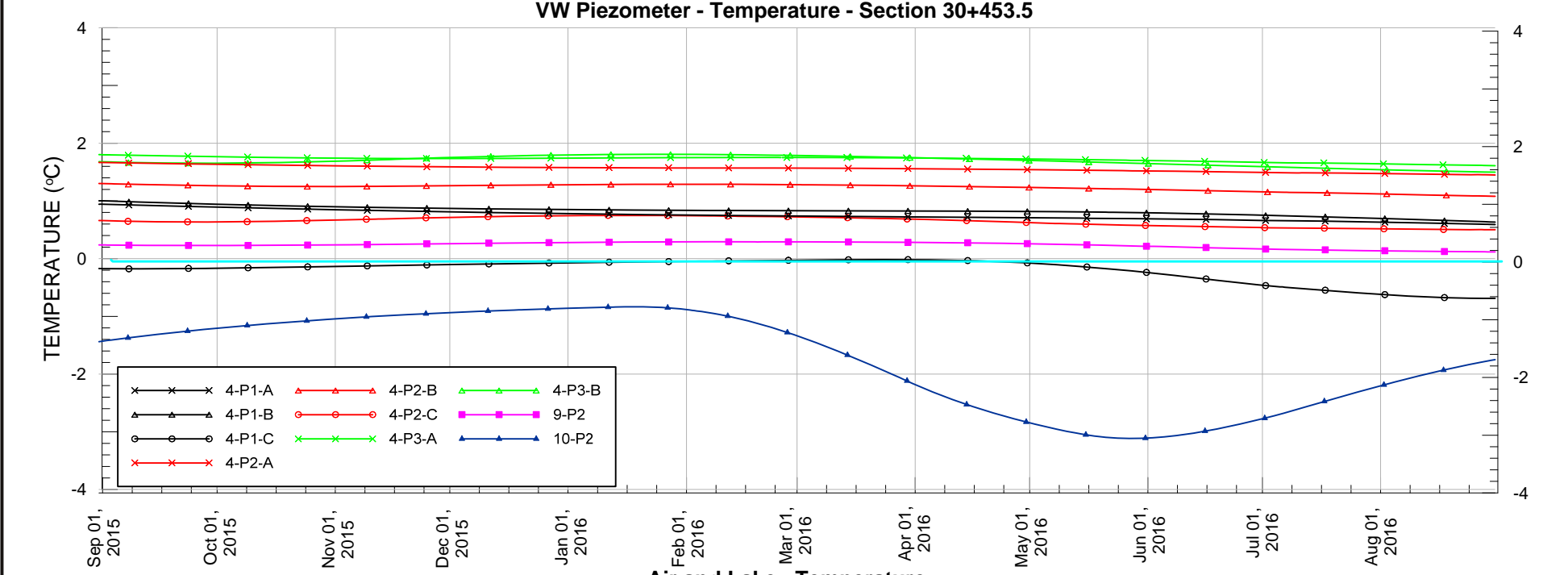
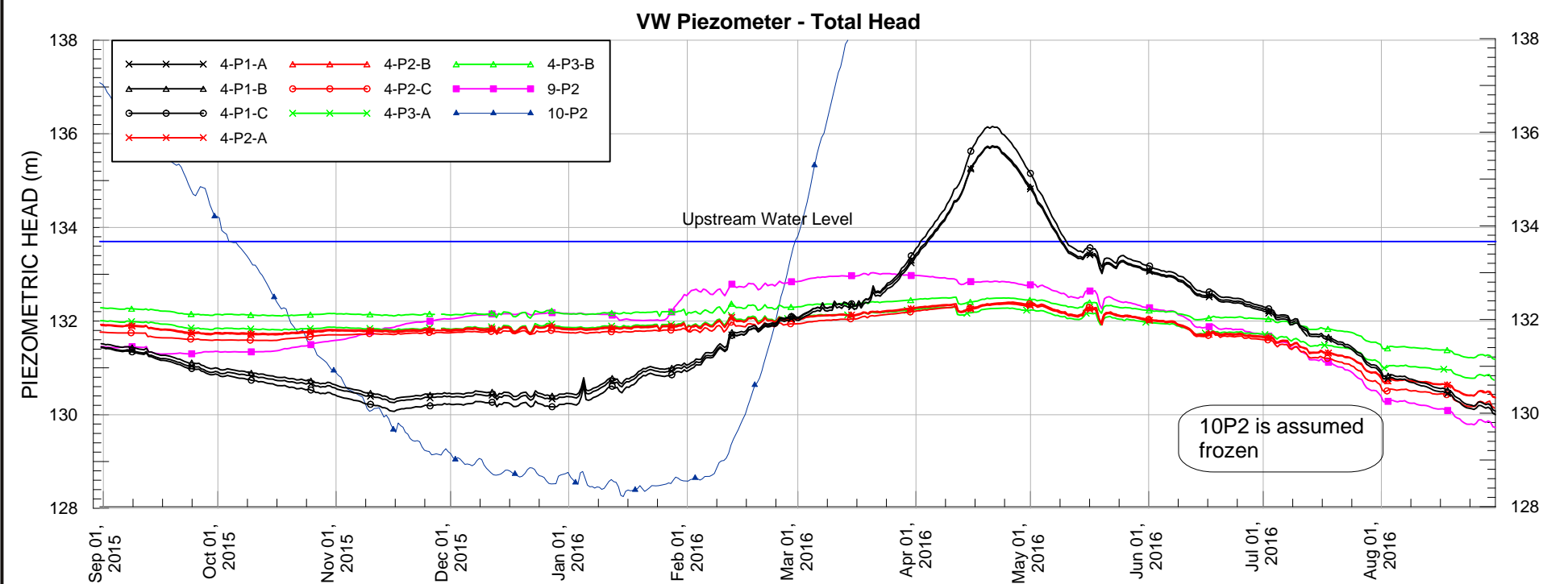
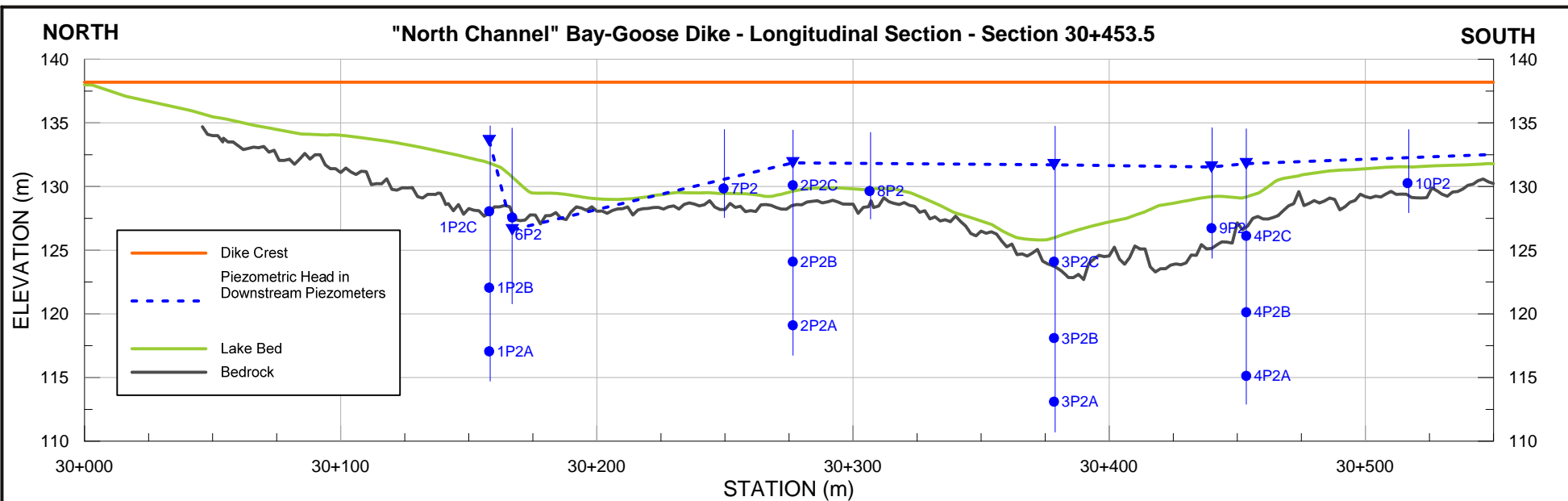

PROJECT			
AGNICO EAGLE MINES LIMITED MEADOWBANK GOLD PROJECT NUNAVUT			
TITLE			
BAYGOOSE DIKE Section 30+453.5 - PIEZOMETRIC DATA (Aug 31/15 to Aug 31/16)			
	PROJECT No.		PHASE No.
	DESIGN	TD	28AUG14
	CADD	TD	28AUG14
	CHECK	PG	28AUG14
REVIEW			SCALE AS SHOWN
			FIGURE 7

STATION 30+453.5

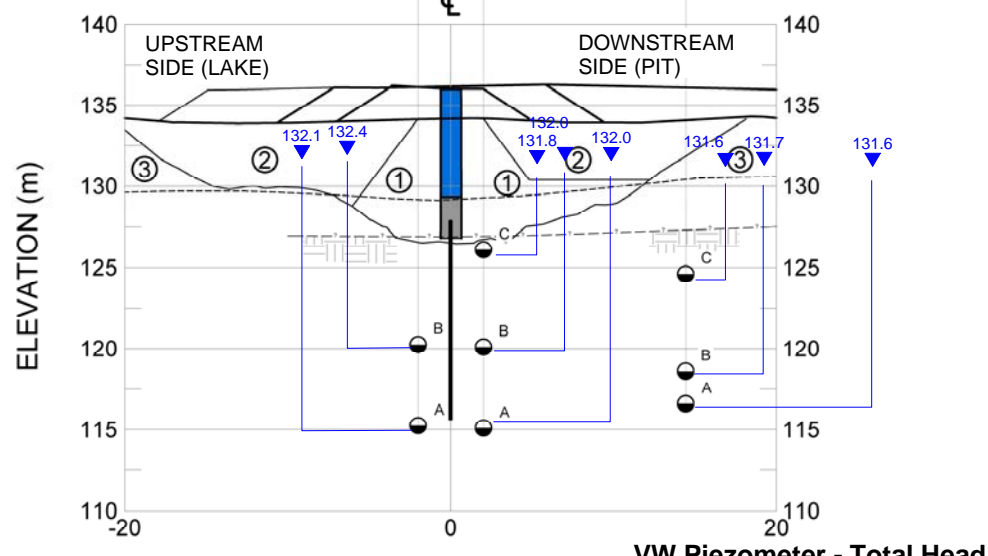

- LEGEND**
- CUTOFF (GSB)
 - CUTOFF (SB)
 - INITIAL ROCKFILL
 - LAKEBED
 - BEDROCK
 - JET GROUT
 - GROUT
 - CORE BACKFILL (19 mm MINUS)
 - COARSE BACKFILL (15mm MINUS)
 - ROCKFILL
 - FINE ROCKFILL
 - TOTAL HEAD (m) ON July 7, 2015

VW Piezometer - Total Head

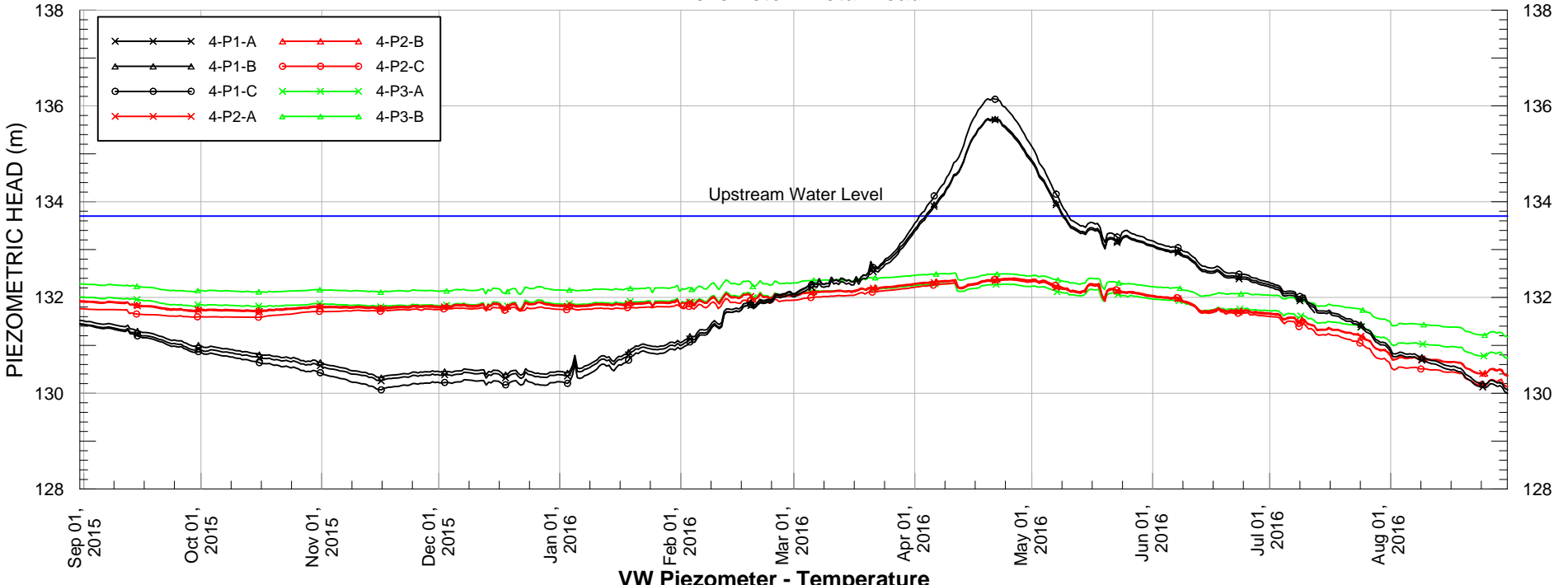

VW Piezometer - Temperature

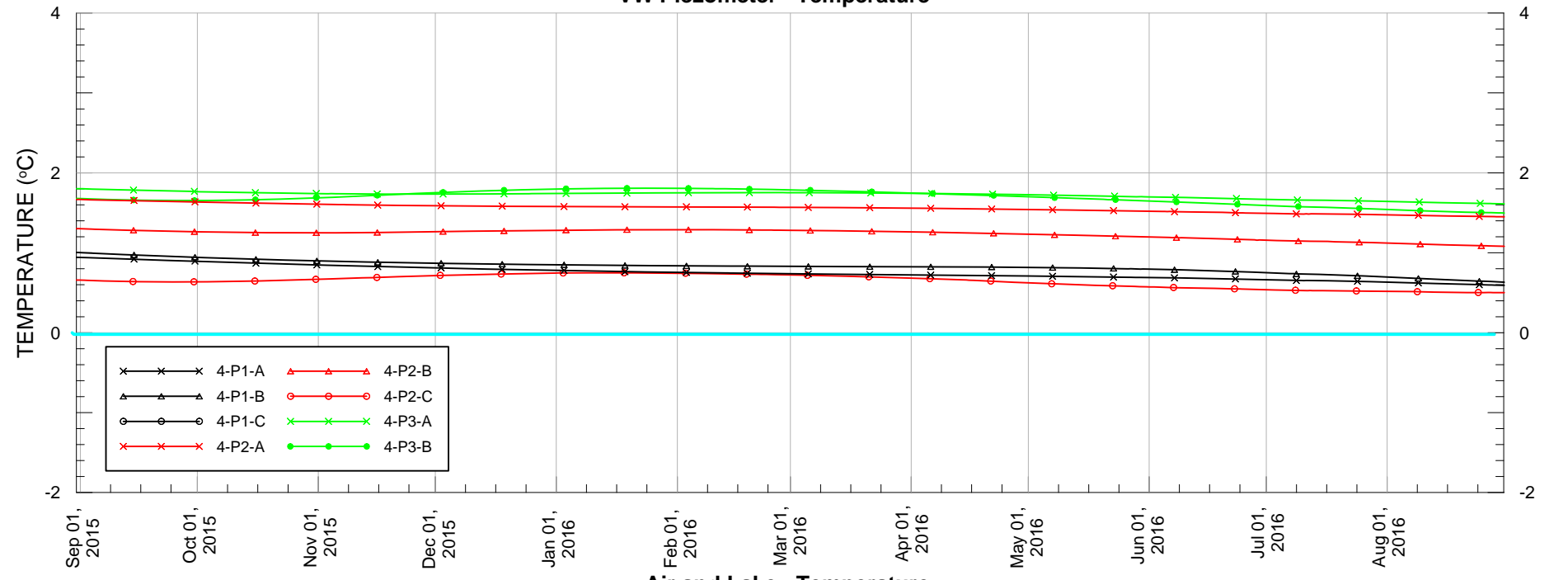

Air and Lake - Temperature

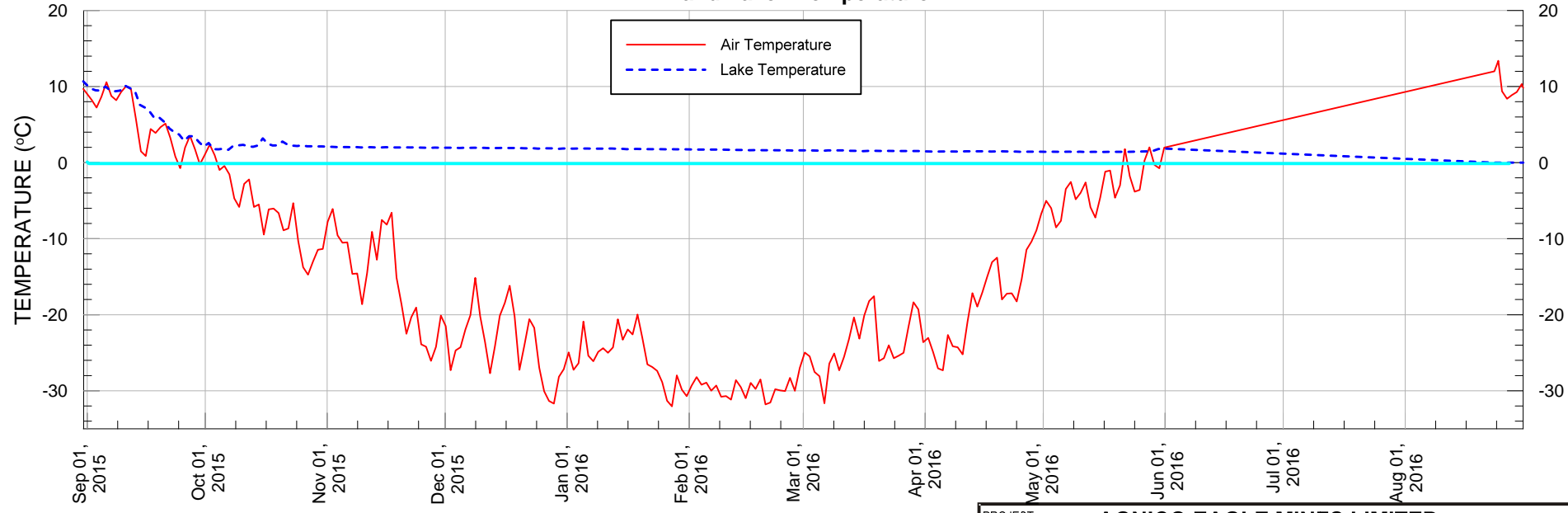

PROJECT				AGNICO EAGLE MINES LIMITED MEADOWBANK GOLD PROJECT NUNAVUT			
TITLE				BAYGOOSE DIKE - SECTION 30+453.5 PIEZOMETRIC DATA (Aug 31/15 to Aug 31/16)			
PROJECT No.		PHASE No.		DESIGN		SCALE AS SHOWN	
CADD		TD		28AUG14		REVIEW	
CHECK		PG		28AUG14		FIGURE 8	
REVIEW							



STATION 30+645.5 5P3 5P2 5P1

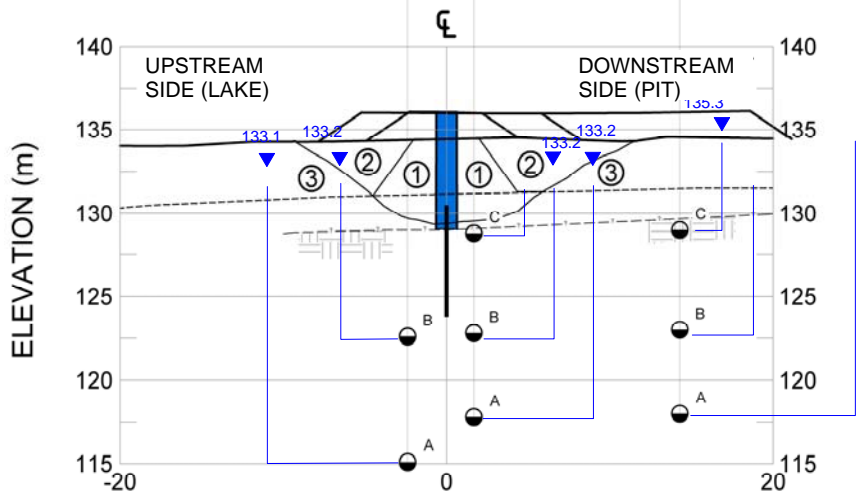

- LEGEND**
- CUTOFF (CSB)
 - CUTOFF (SB)
 - INITIAL ROCKFILL
 - LAKEBED
 - BEDROCK
 - JET GROUT
 - GROUT
 - 1 CORE BACKFILL (19 mm MINUS)
 - 2 COARSE BACKFILL (15mm MINUS)
 - 3 ROCKFILL
 - 4 FINE ROCKFILL
 - ▼ TOTAL HEAD (m) ON July 7, 2015

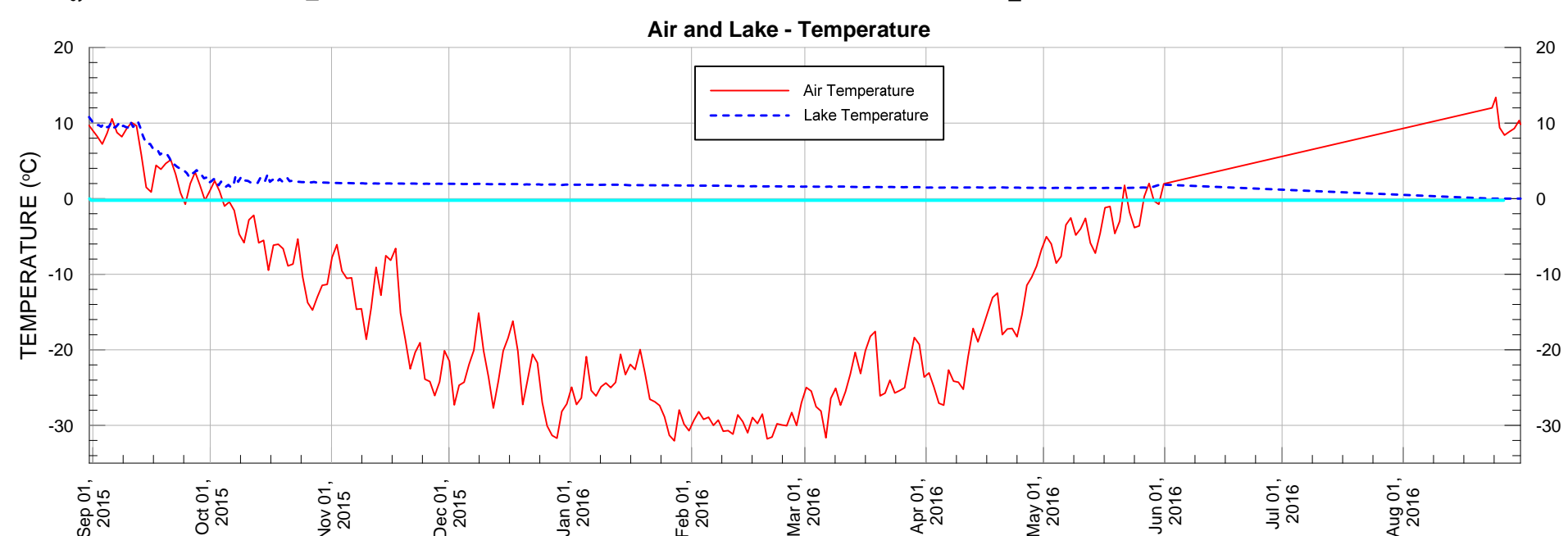
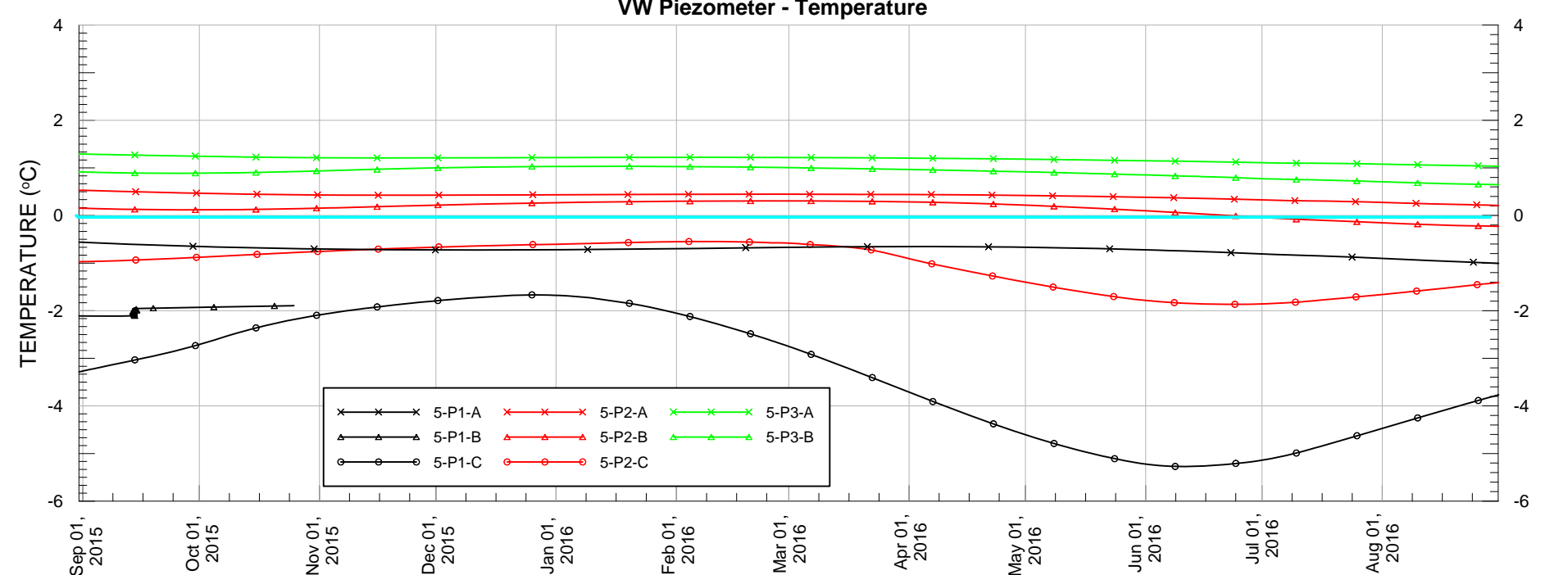
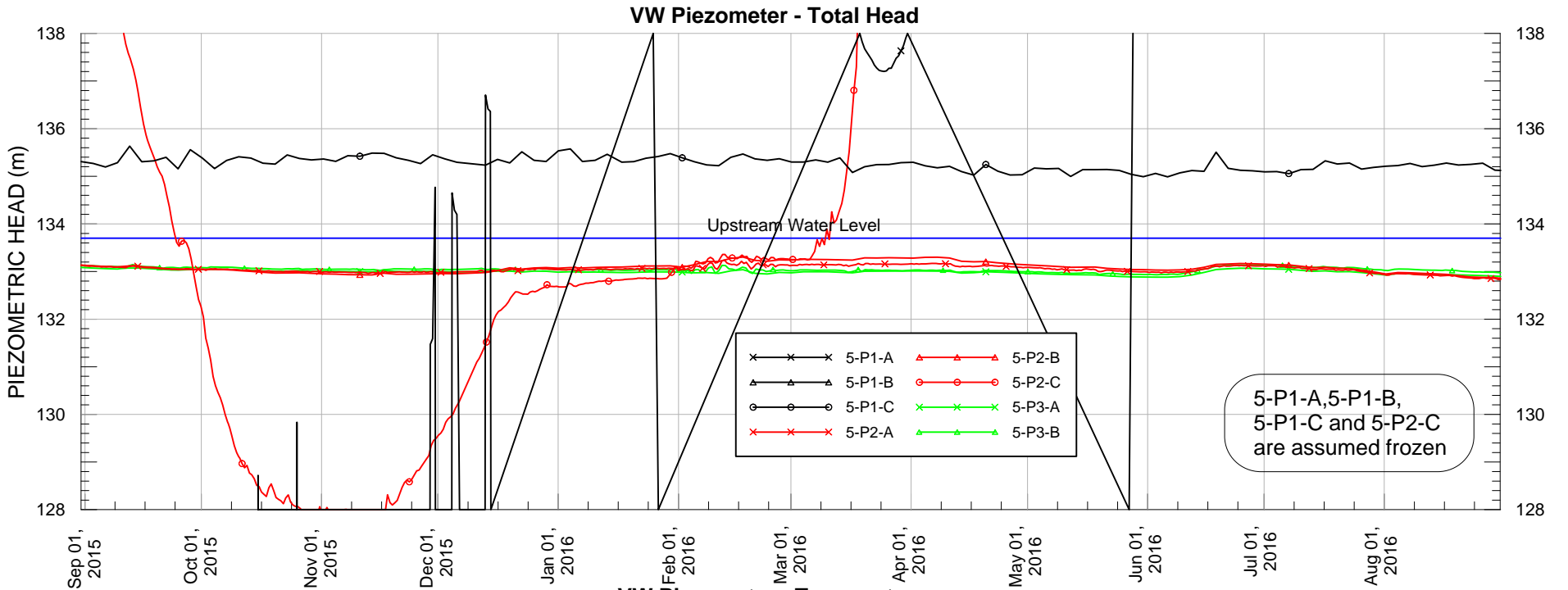

PROJECT	AGNICO EAGLE MINES LIMITED MEADOWBANK GOLD PROJECT NUNAVUT		
TITLE	BAYGOOSE DIKE - SECTION 30+645.5 PIEZOMETRIC DATA (Aug 31/15 to Aug 31/16)		
	PROJECT No.	PHASE No.	FIGURE 10
	DESIGN TD 17JAN14	SCALE AS SHOWN	
	CADD TD 17JAN14	REV.	
	CHECK		
REVIEW			

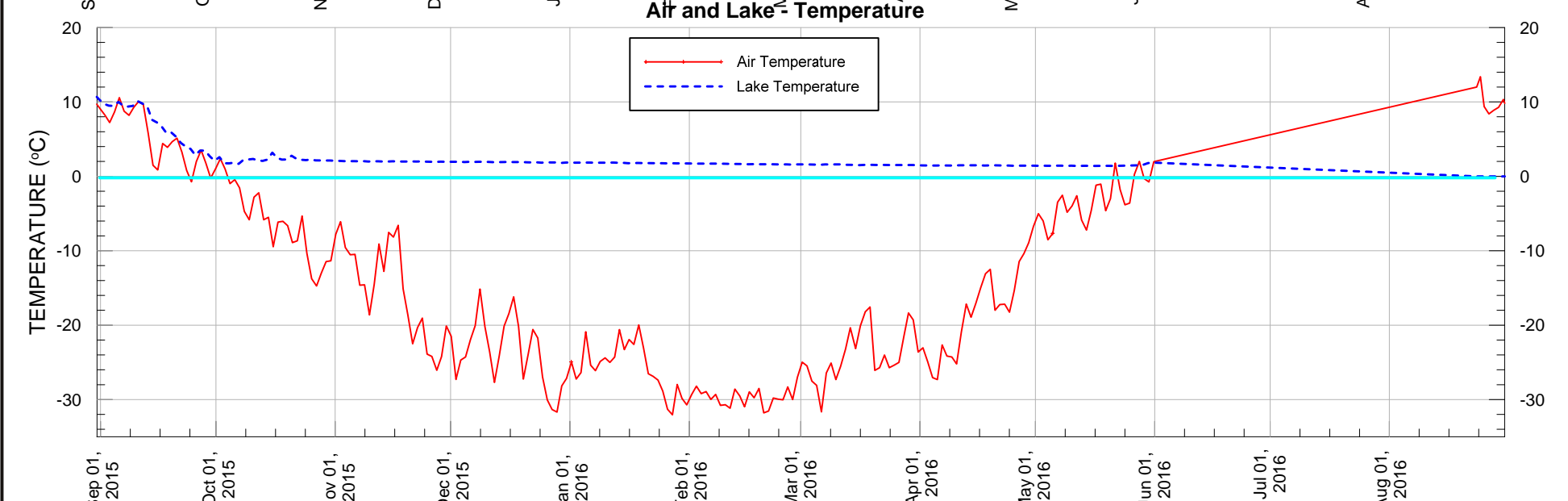
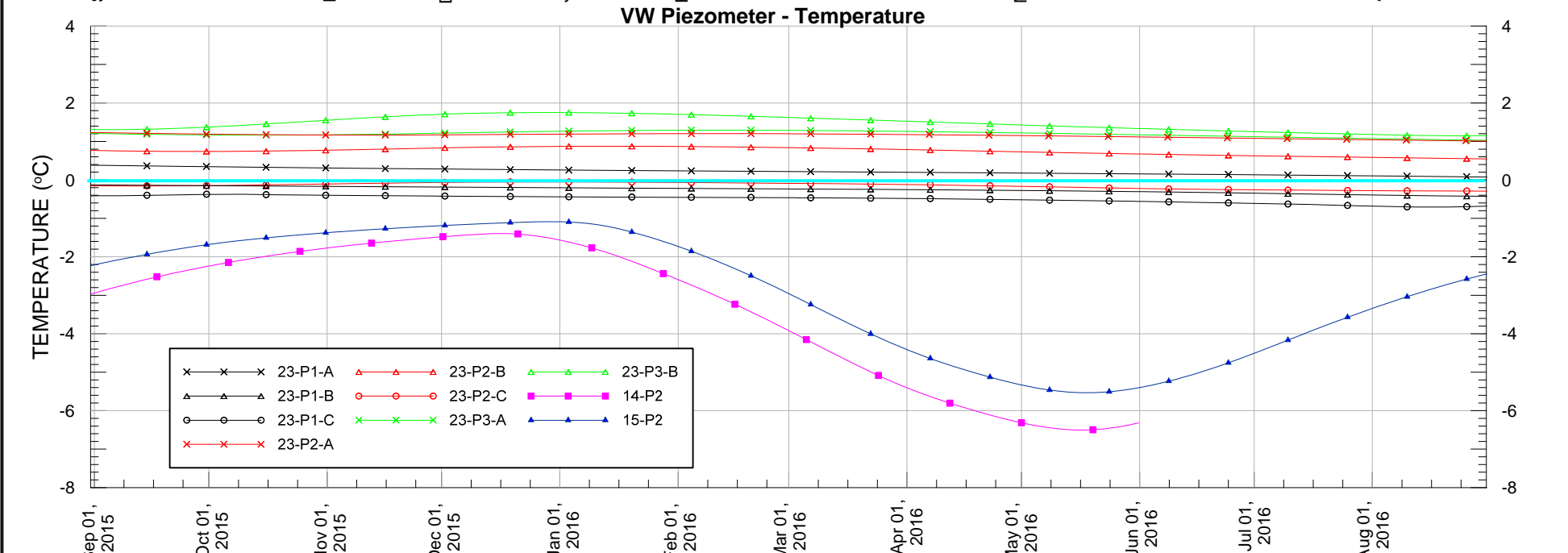
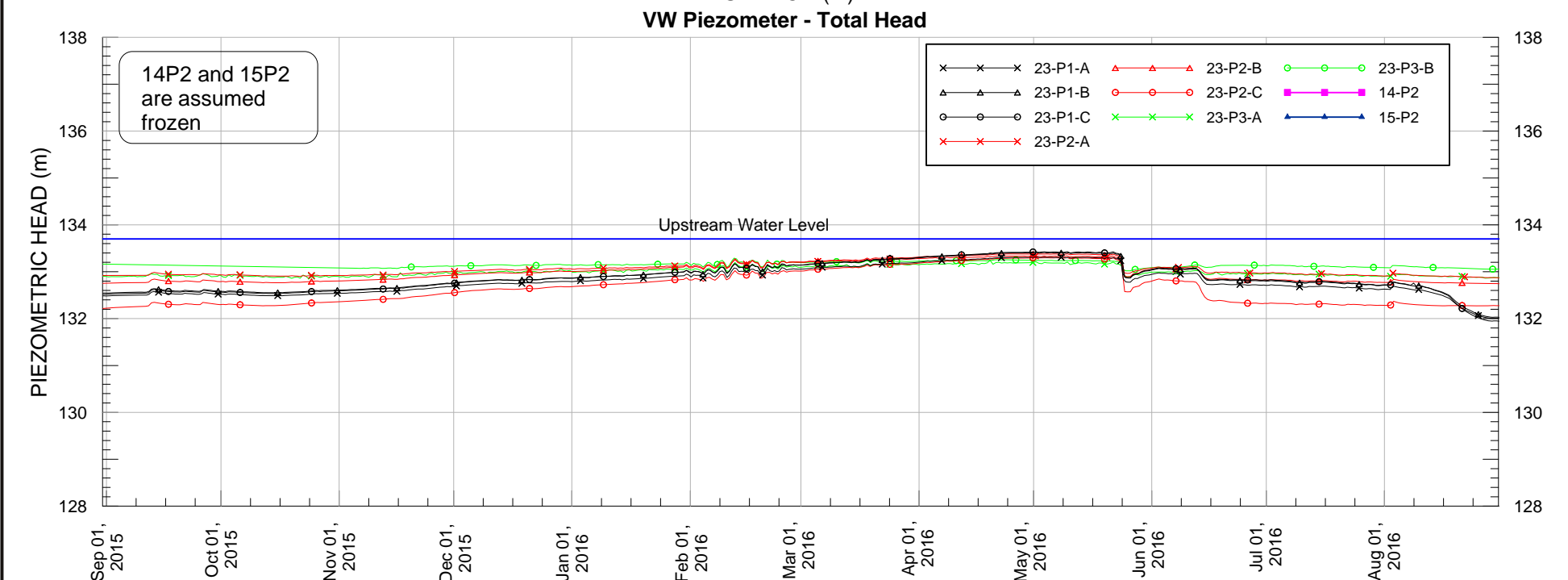
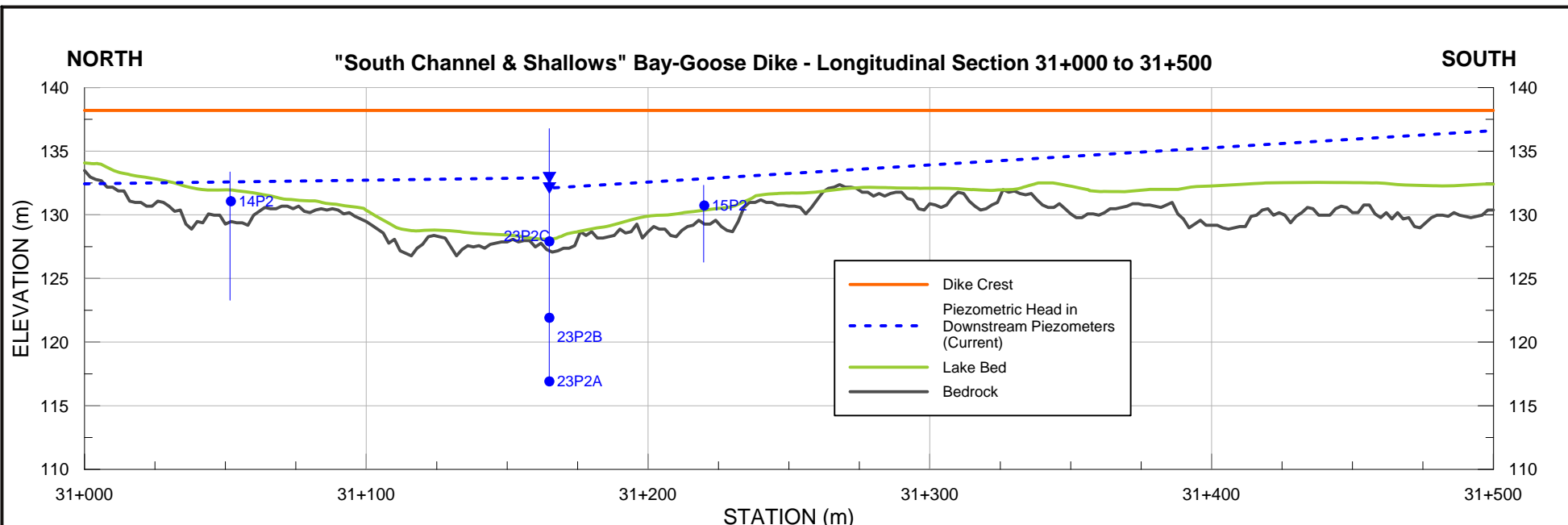

PROJECT		AGNICO EAGLE MINES LIMITED MEADOWBANK GOLD PROJECT NUNAVUT		
TITLE		BAYGOOSE DIKE 31+000 to 31+500 - PIEZOMETRIC DATA (Aug 31/15 to Aug 31/16)		
	PROJECT No.	PHASE No.		FIGURE 11
	DESIGN TD 28AUG14	SCALE	AS SHOWN	
	CADD TD 28AUG14	REVIEW		
	CHECK PG 28AUG14			
REVIEW				

STATION 31+165

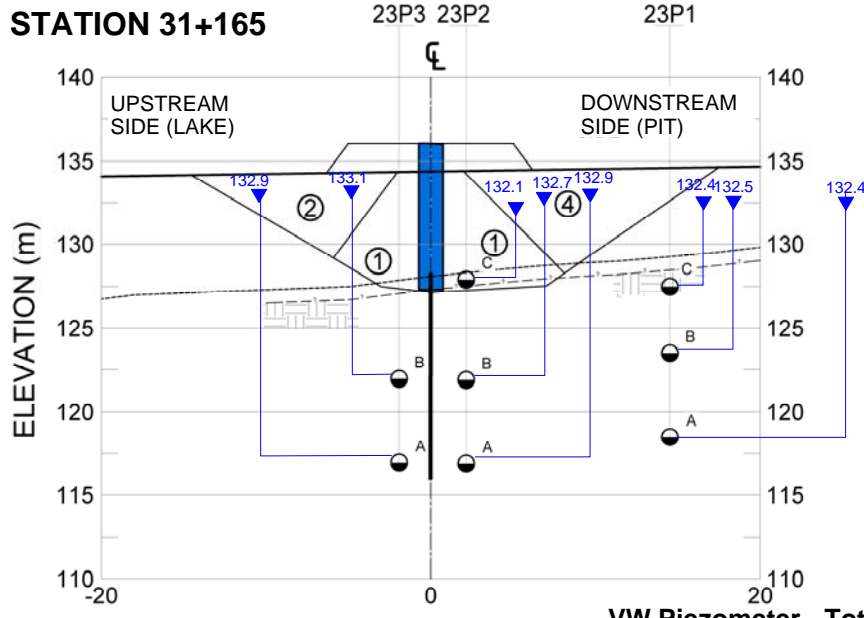

LEGEND

- CUTOFF (CSB)
- CUTOFF (SB)
- INITIAL ROCKFILL
- LAKEBED
- BEDROCK
- JET GROUT
- GROUT
- ① CORE BACKFILL (19 mm MINUS)
- ② COARSE BACKFILL (15mm MINUS)
- ③ ROCKFILL
- ④ FINE ROCKFILL
- ▼ TOTAL HEAD (m) ON July 7, 2015

VW Piezometer - Total Head

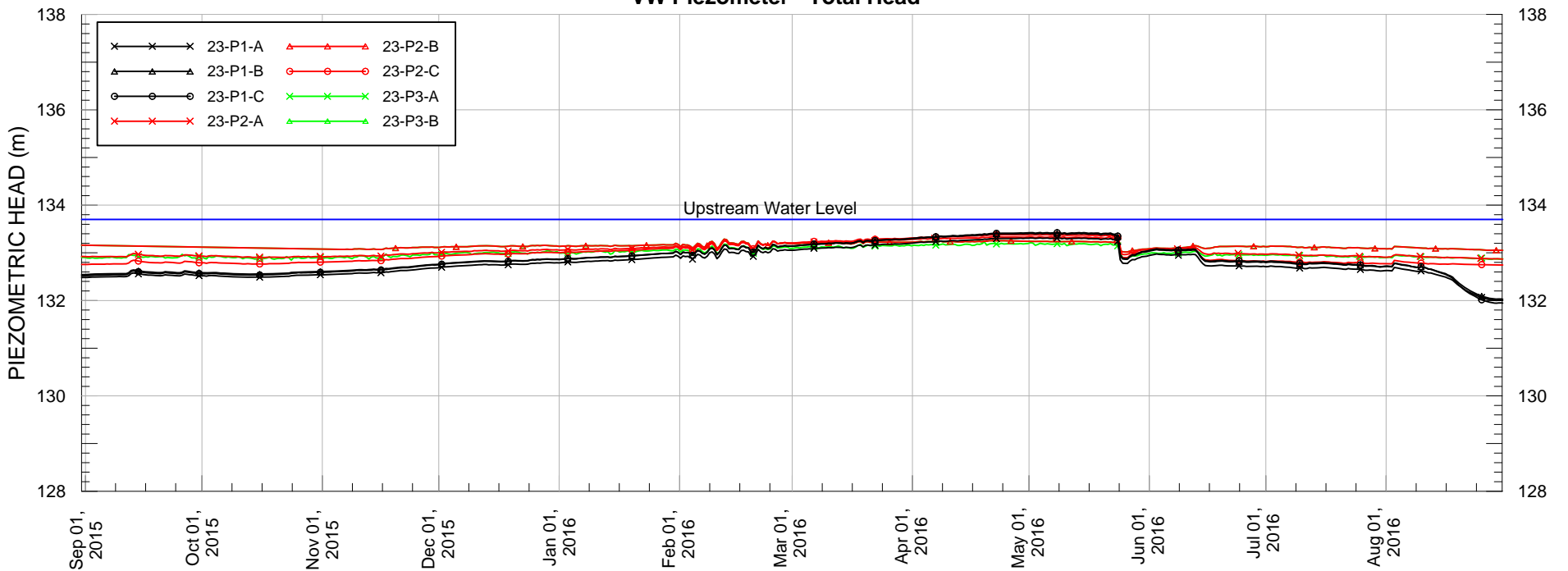

VW Piezometer - Temperature

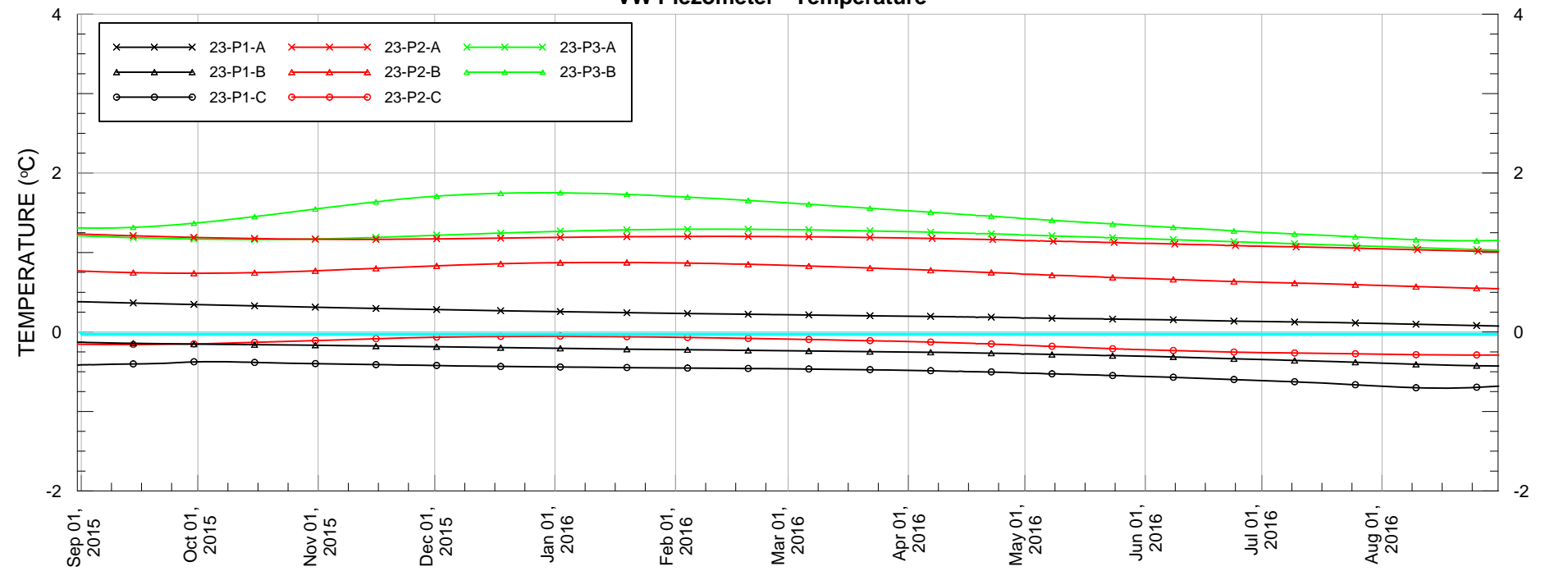

Air and Lake - Temperature

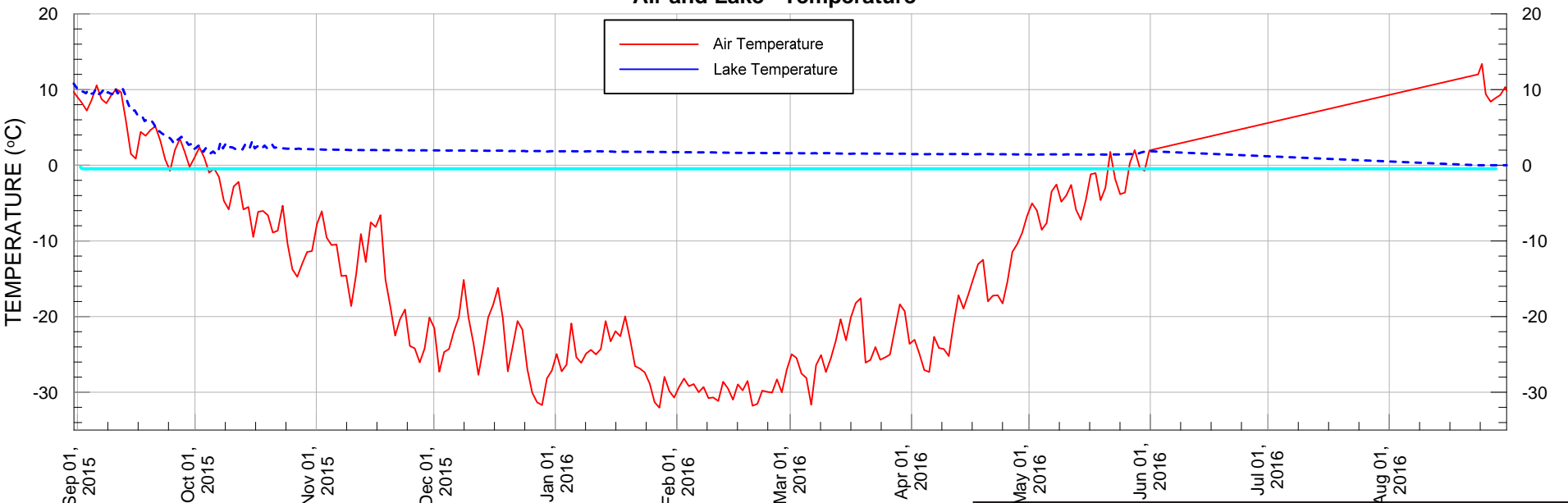

PROJECT				
AGNICO EAGLE MINES LIMITED MEADOWBANK GOLD PROJECT NUNAVUT				
TITLE				
BAYGOOSE DIKE - SECTION 31+165 PIEZOMETRIC DATA (Aug 31/15 to Aug 31/16)				
	PROJECT No.		PHASE No.	
	DESIGN	TD	28AUG14	SCALE AS SHOWN
	CADD	TD	28AUG14	REV.
	CHECK	PG	28AUG14	FIGURE 12
REVIEW				

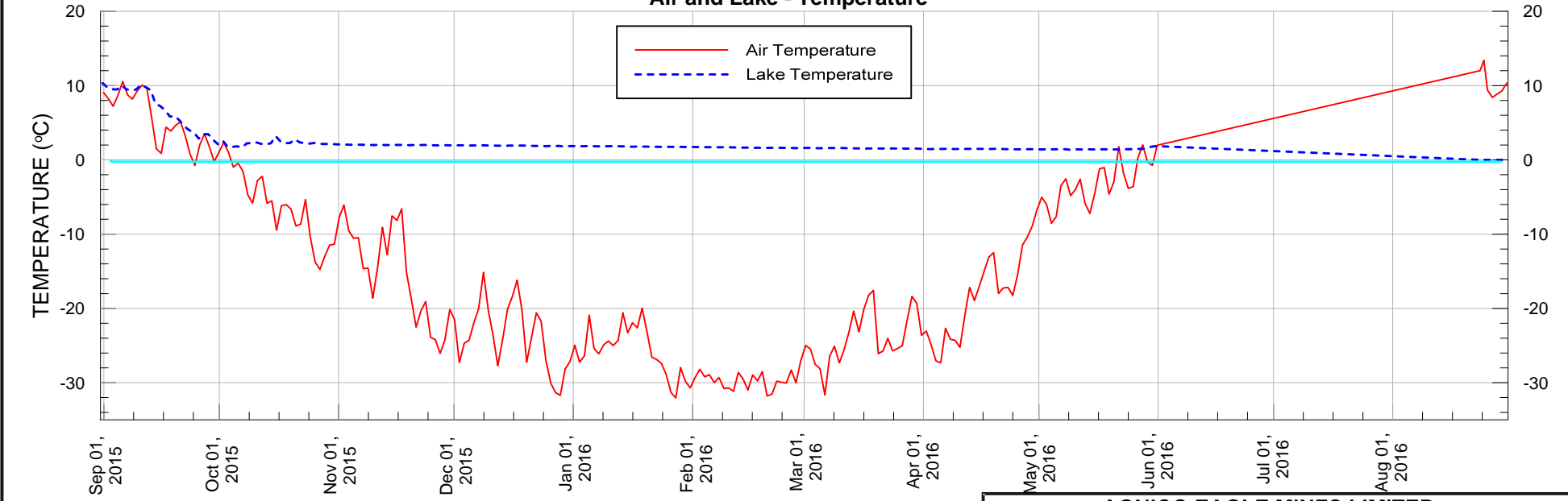
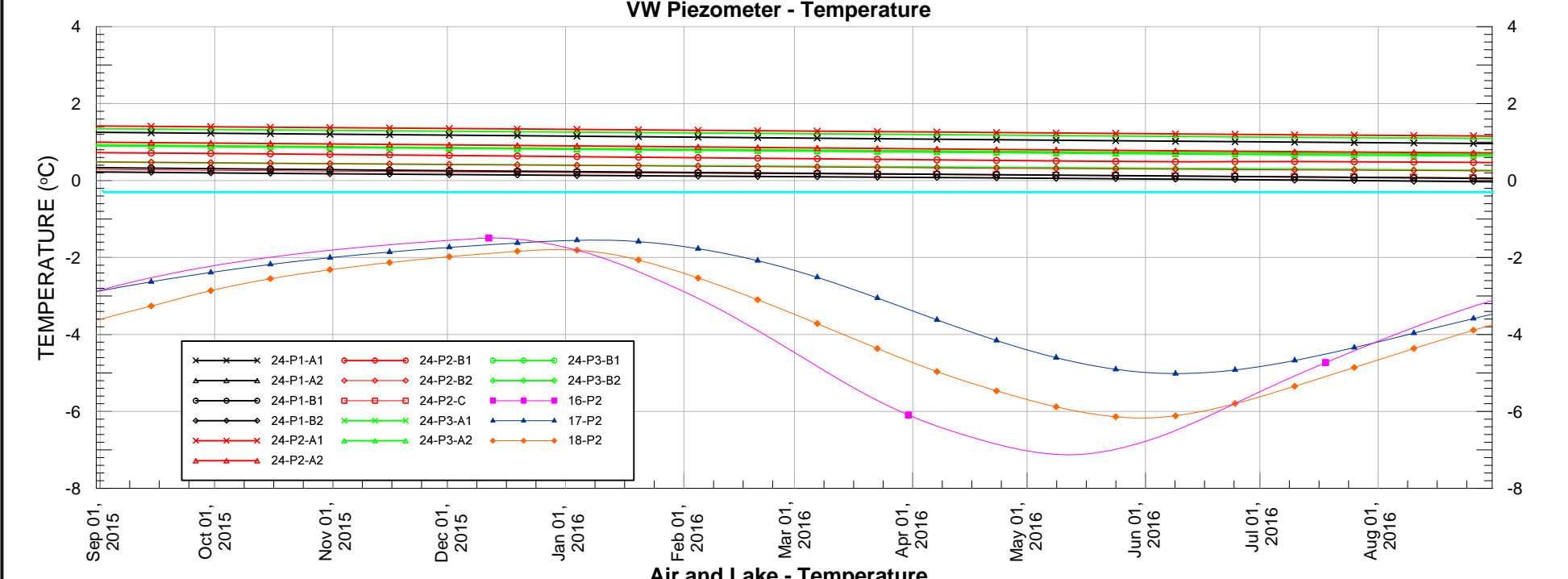
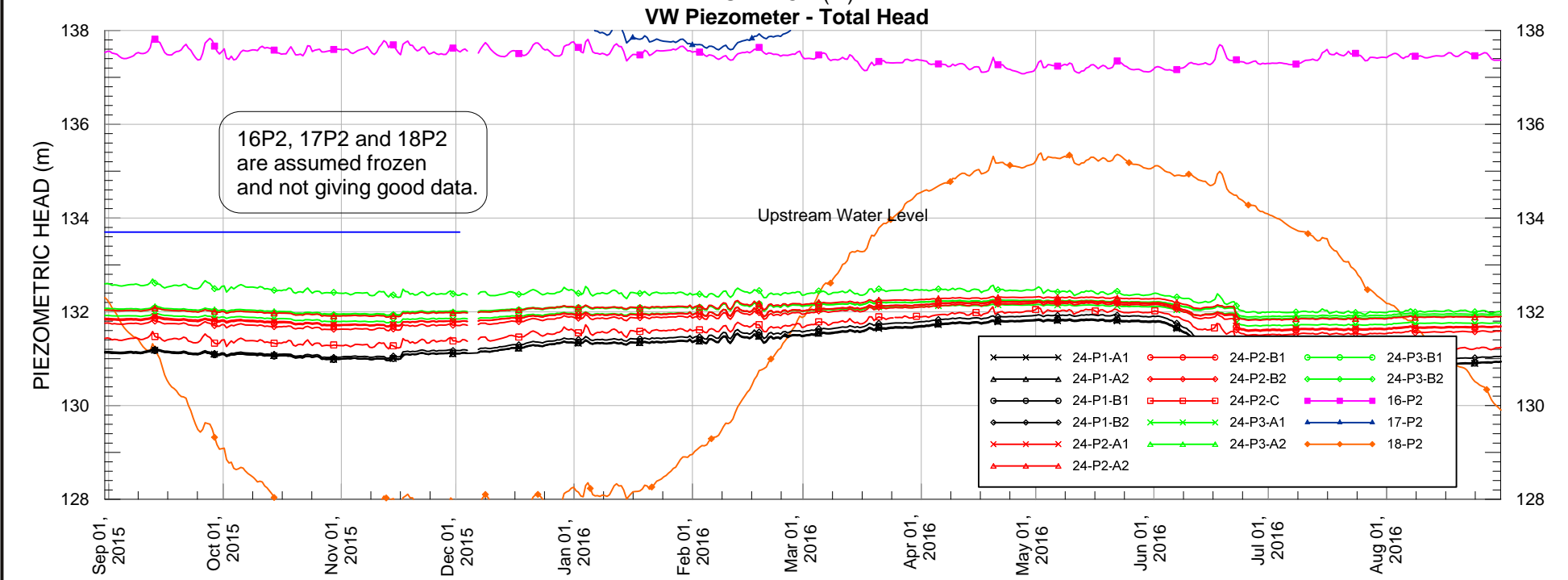
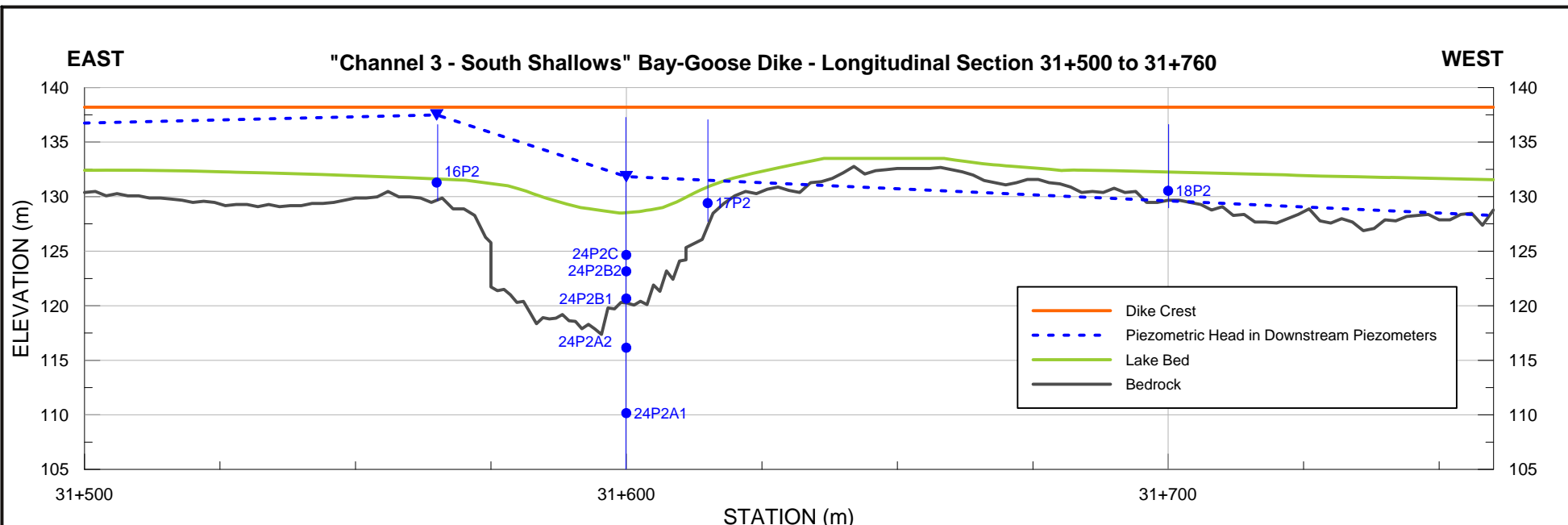

PROJECT		AGNICO EAGLE MINES LIMITED MEADOWBANK GOLD PROJECT NUNAVUT		
TITLE		BAYGOOSE DIKE 31+500 to 31+760 - PIEZOMETRIC DATA (Aug 31/15 to Aug 31/16)		
	PROJECT No.	PHASE No.		FIGURE 13
	DESIGN TD	28AUG14	SCALE AS SHOWN	
	CADD TD	28AUG14	REV.	
	CHECK PG	28AUG14		
REVIEW				

STATION 31+600

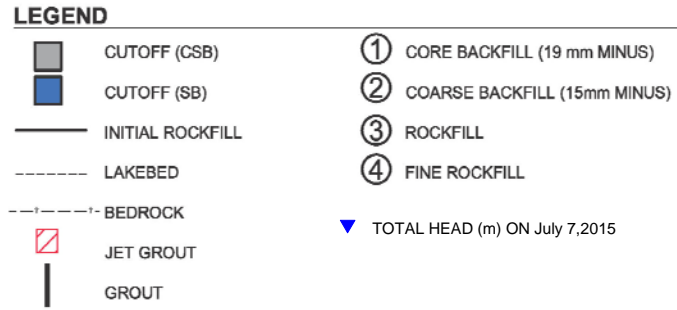
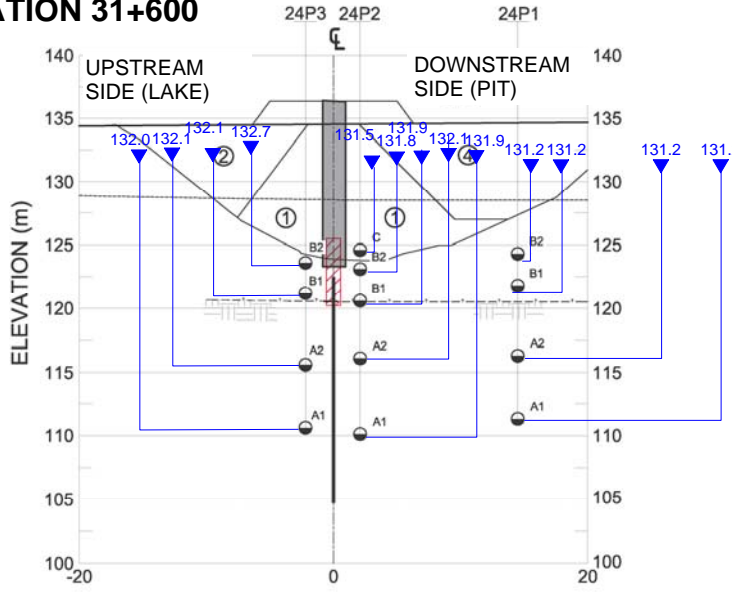

VW Piezometer - Total Head

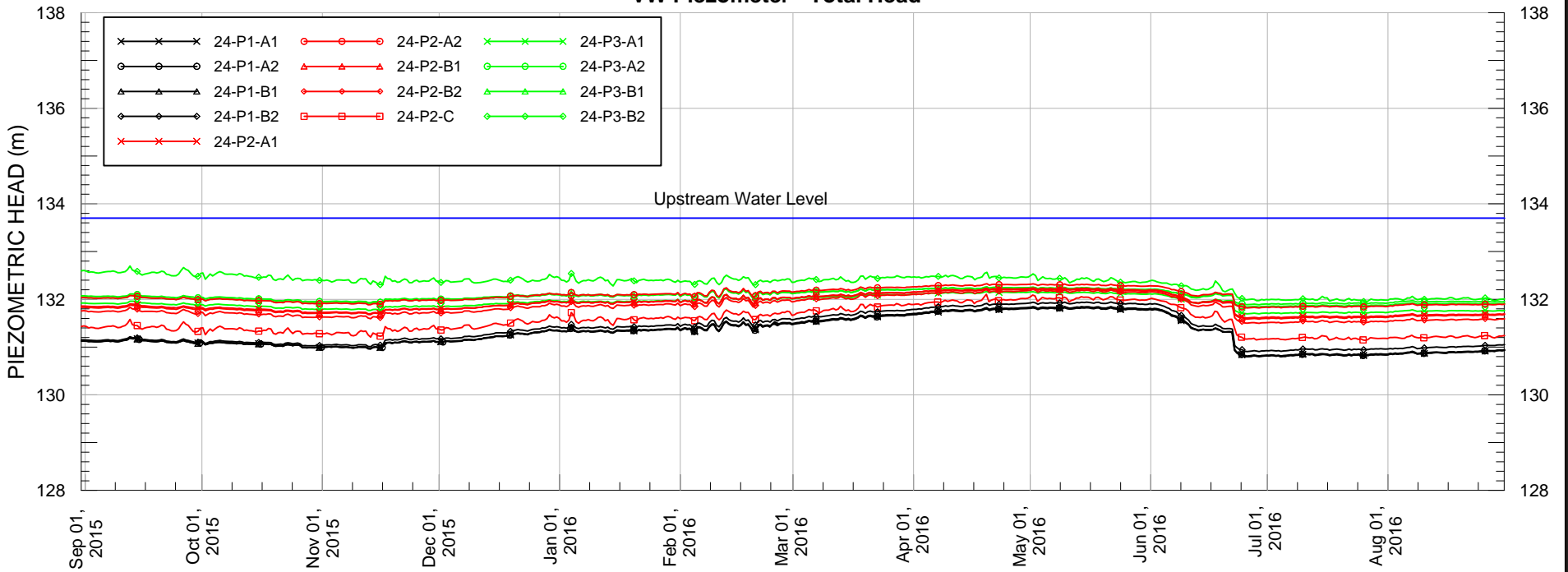

VW Piezometer - Temperature

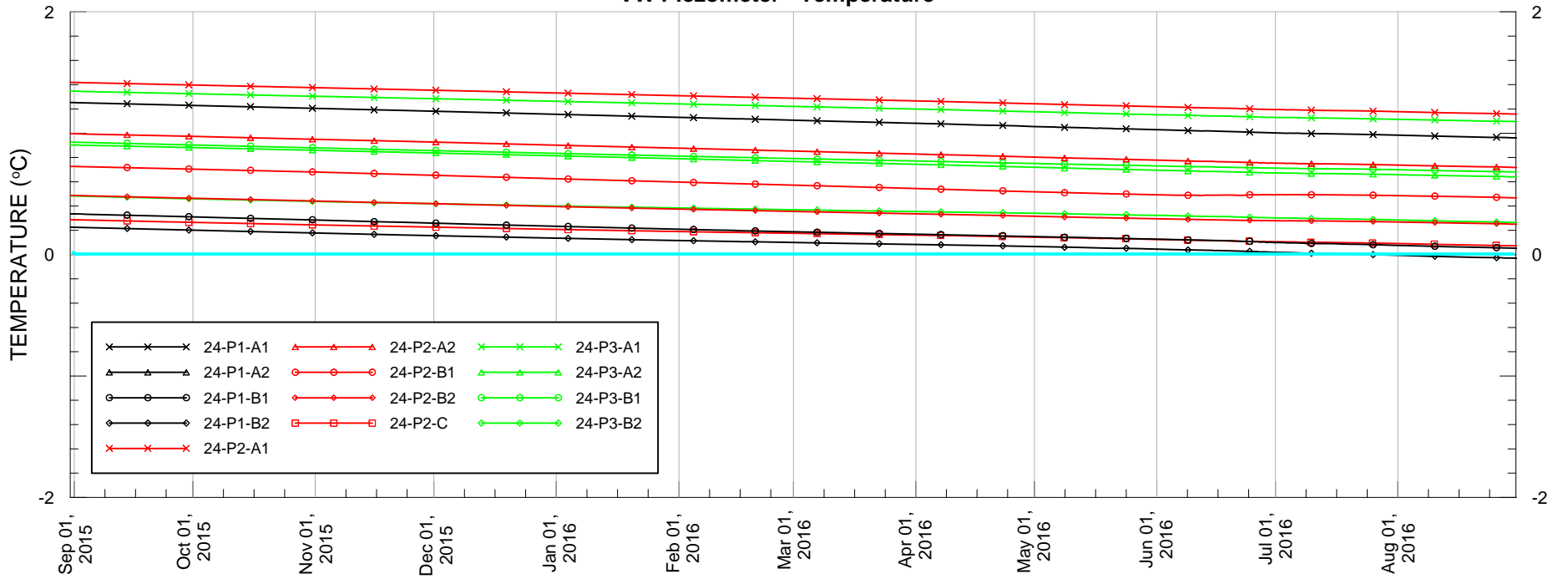

Air and Lake - Temperature

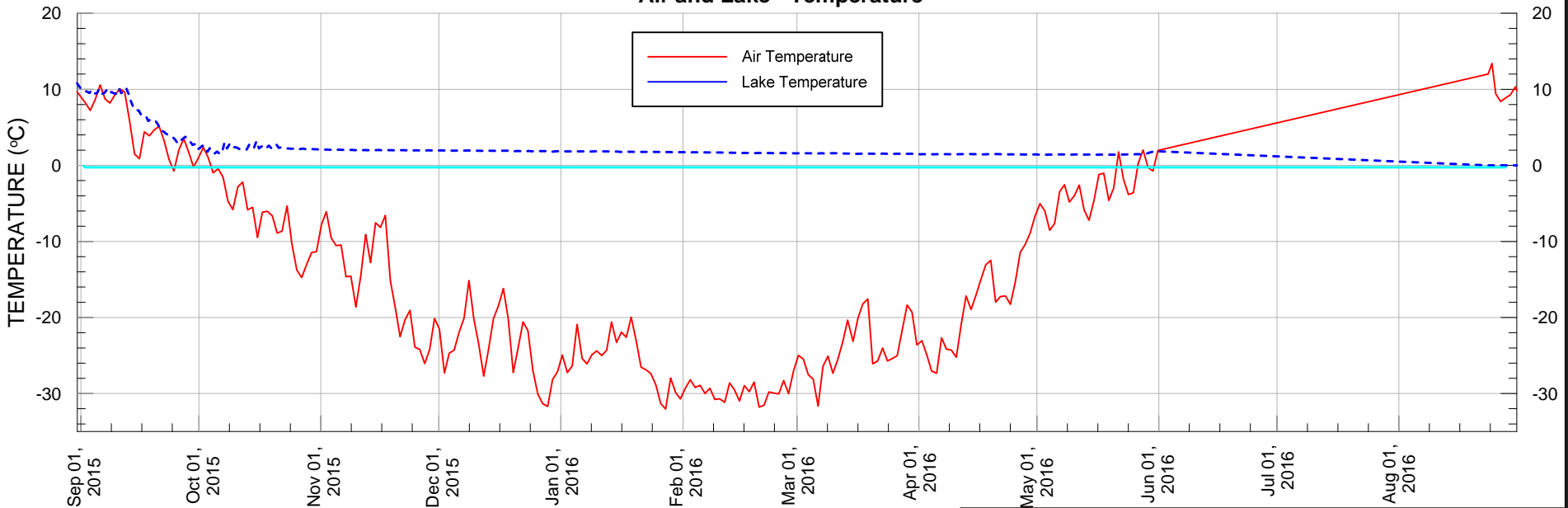

PROJECT			
AGNICO EAGLE MINES LIMITED MEADOWBANK GOLD PROJECT NUNAVUT			
TITLE			
BAYGOOSE DIKE - SECTION 31+600 PIEZOMETRIC DATA (Aug 31/15 to Aug 31/16)			
		PROJECT No. DESIGN TD 28AUG14 CADD TD 28AUG14 CHECK PG 28AUG14 REVIEW	PHASE No. SCALE AS SHOWN REV.
AGNICO EAGLE			FIGURE 14

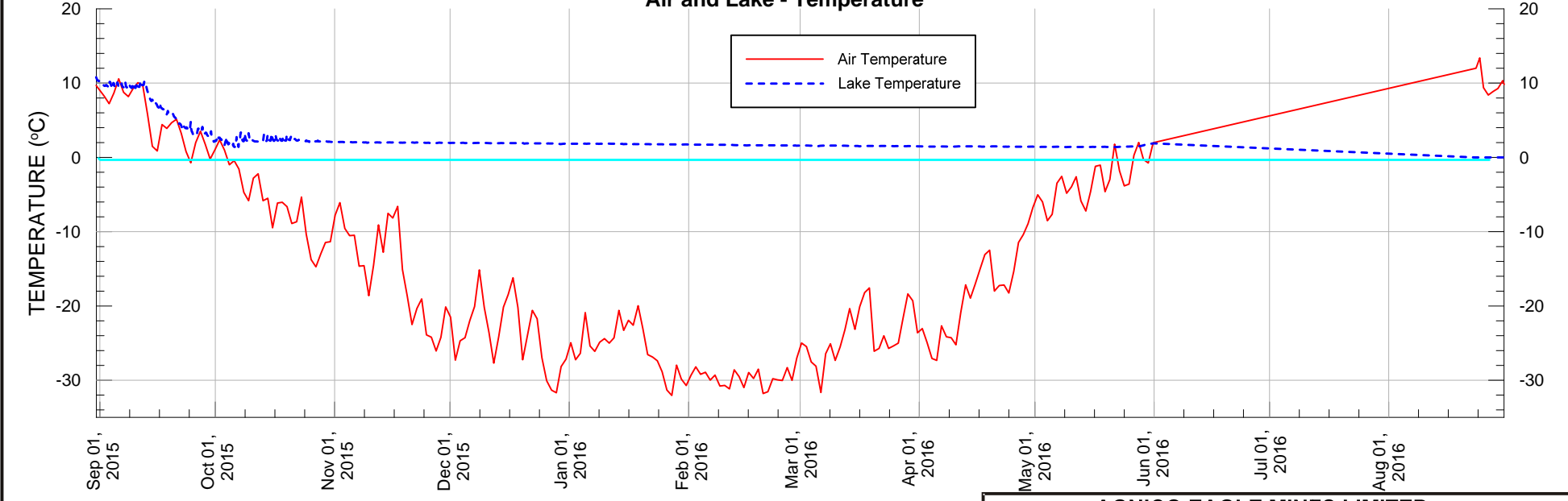
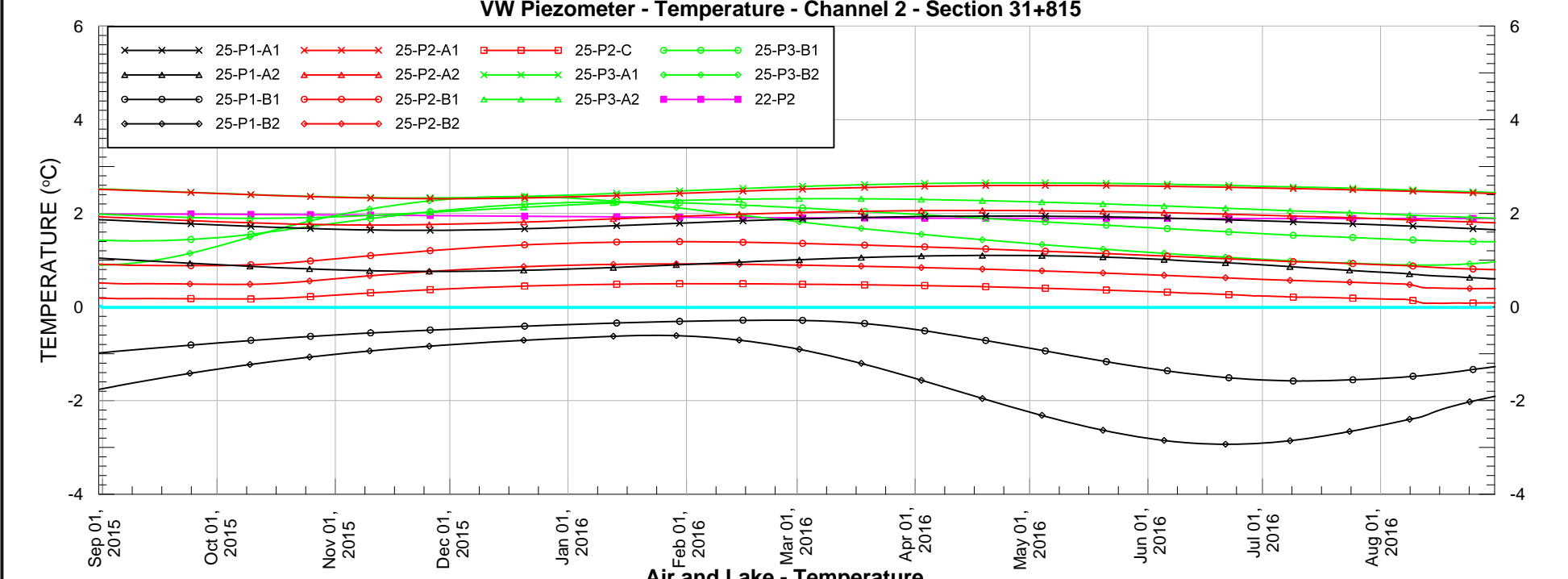
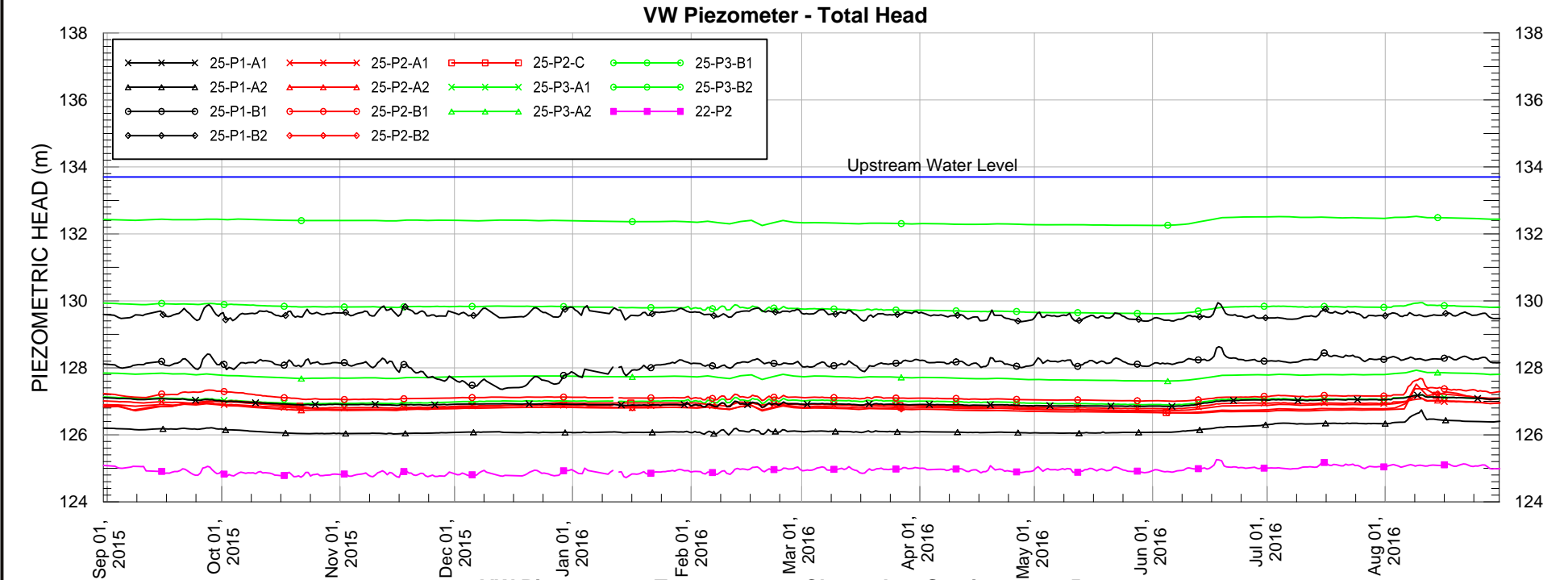
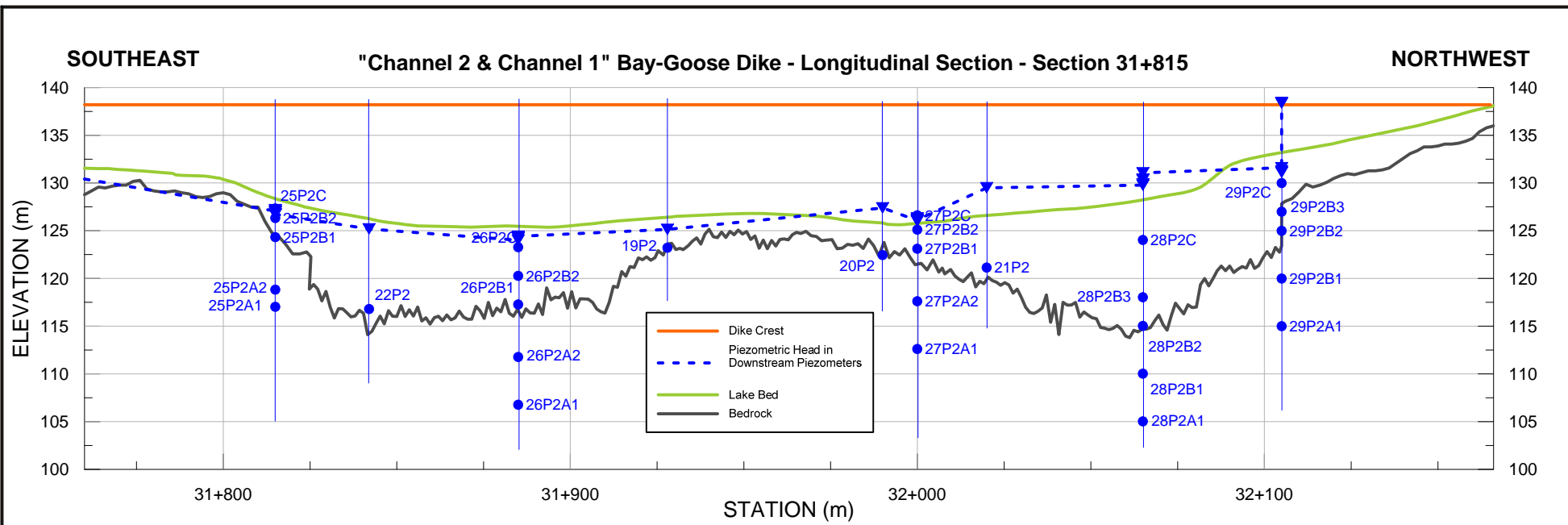

PROJECT	AGNICO EAGLE MINES LIMITED MEADOWBANK GOLD PROJECT NUNAVUT			
TITLE	BAYGOOSE DIKE Section 31+815 - CHANNEL 2, PIEZOMETRIC DATA (Aug 31/15 to Aug 31/16)			
	PROJECT No.	PHASE No.		
	DESIGN TD 28AUG14	SCALE	AS SHOWN	
	CADD TD 28AUG14	REVIEW		
	CHECK PG 28AUG14	FIGURE 15		
REVIEW				

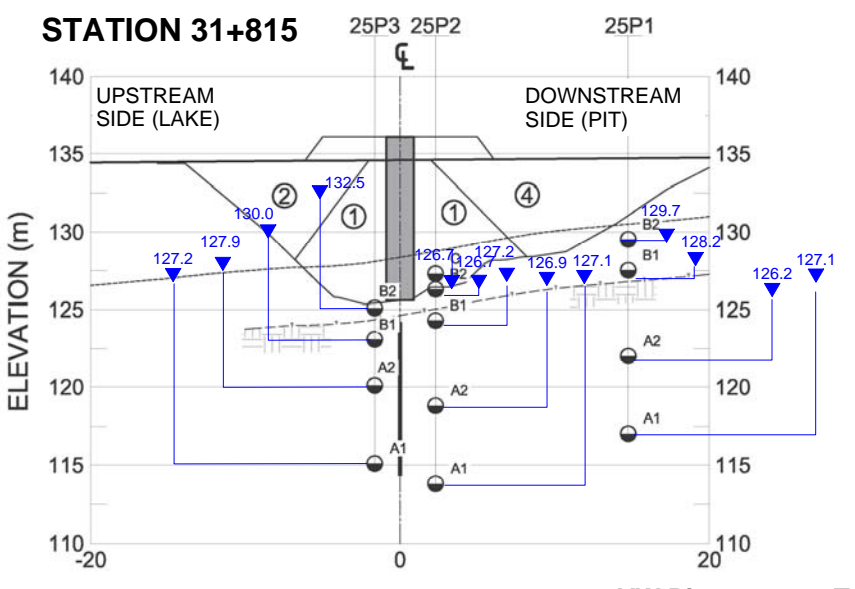

VW Piezometer - Total Head

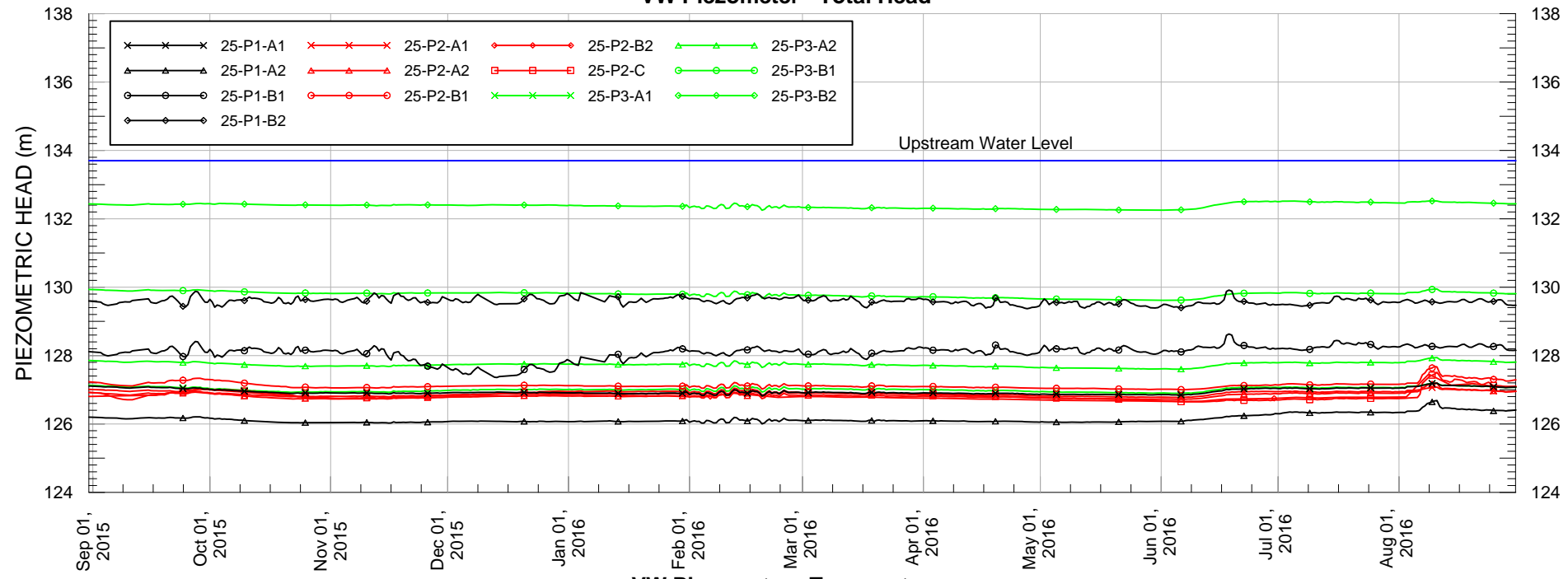

VW Piezometer - Temperature

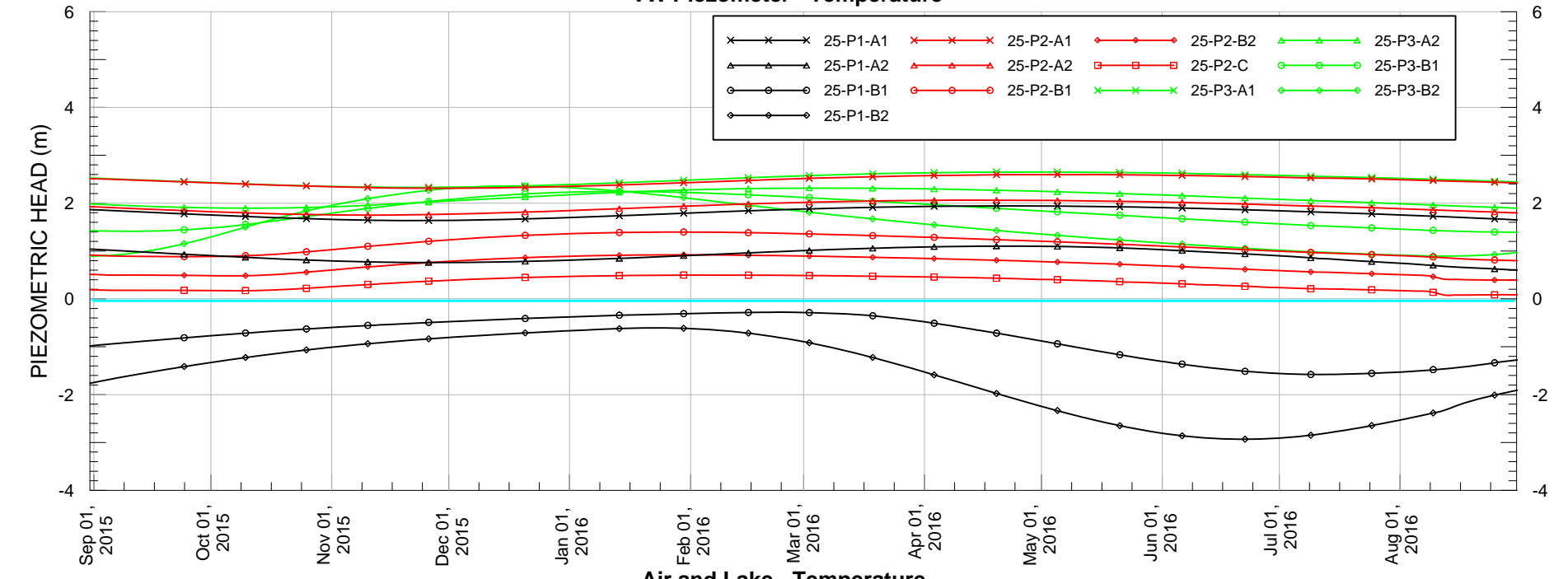

Air and Lake - Temperature

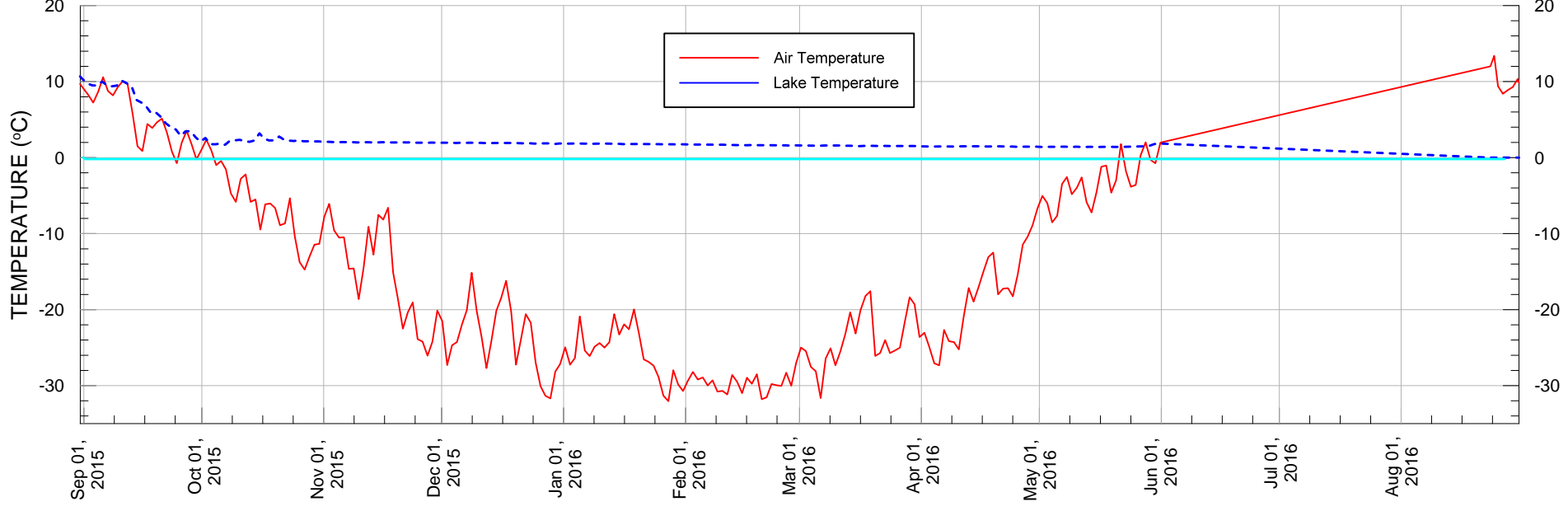

PROJECT	AGNICO EAGLE MINES LIMITED MEADOWBANK GOLD PROJECT NUNAVUT				
TITLE	BAY-GOOSE DIKE - SECTION 31+815 PIEZOMETRIC DATA (Aug 31/15 to Aug 31/16)				
	PROJECT No.	09-1428-5007	PHASE No.	4000	
	DESIGN	TD	28AUG14	SCALE	AS SHOWN
	CADD	TD	28AUG14	REV.	
	CHECK	PG	28AUG14	FIGURE 16	
REVIEW					

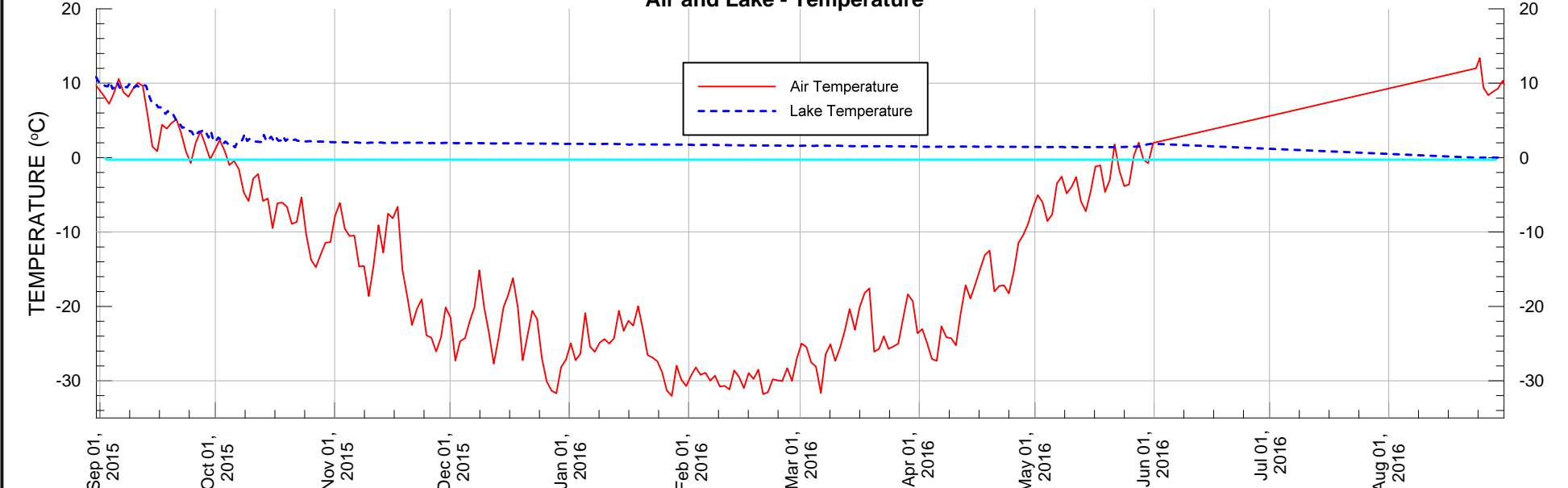
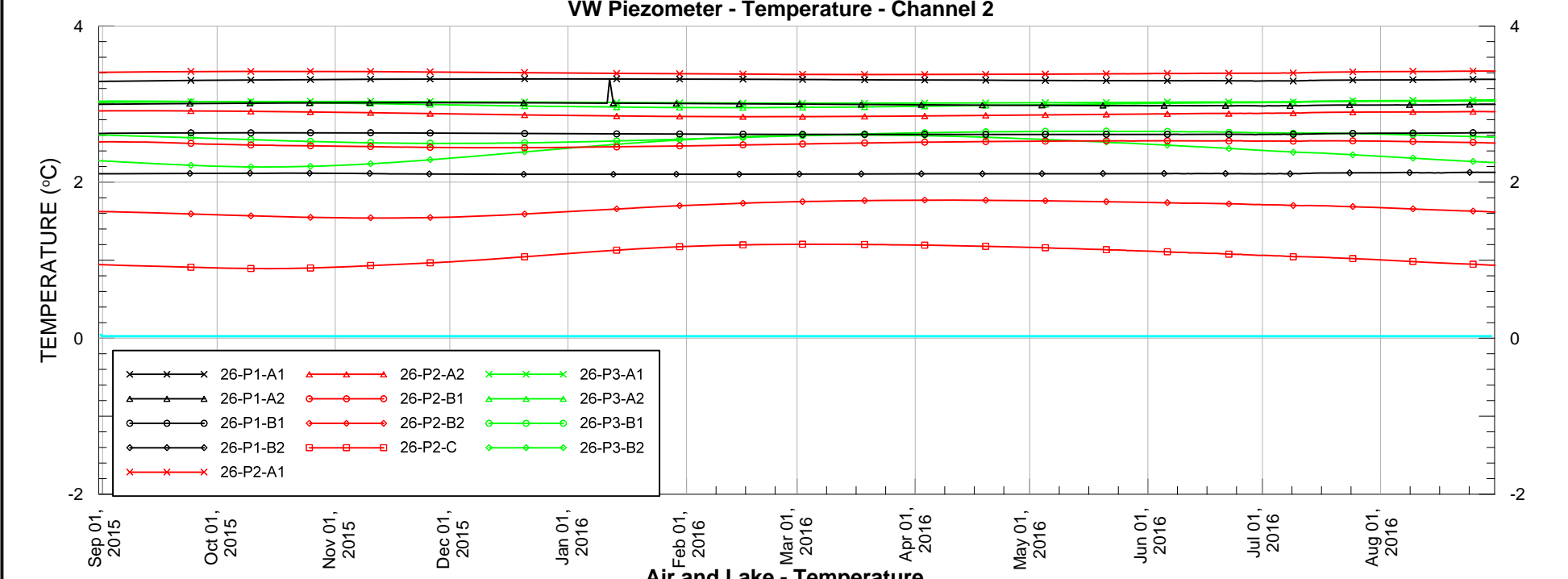
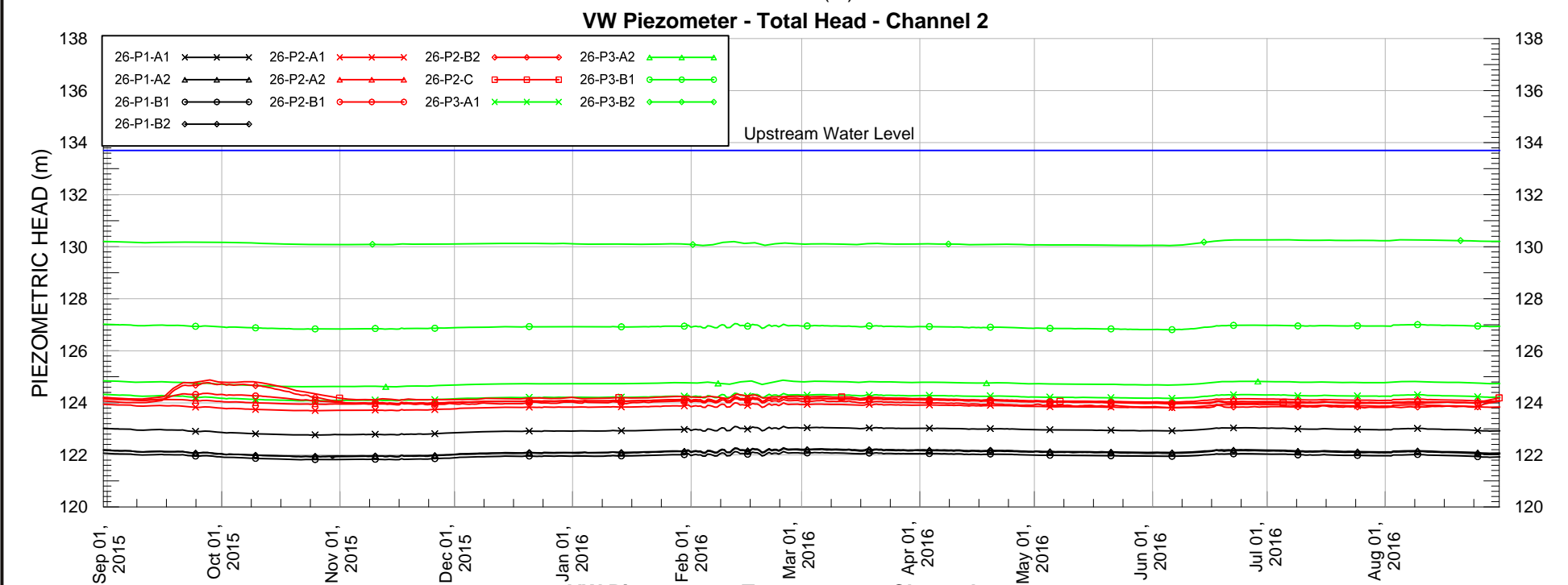
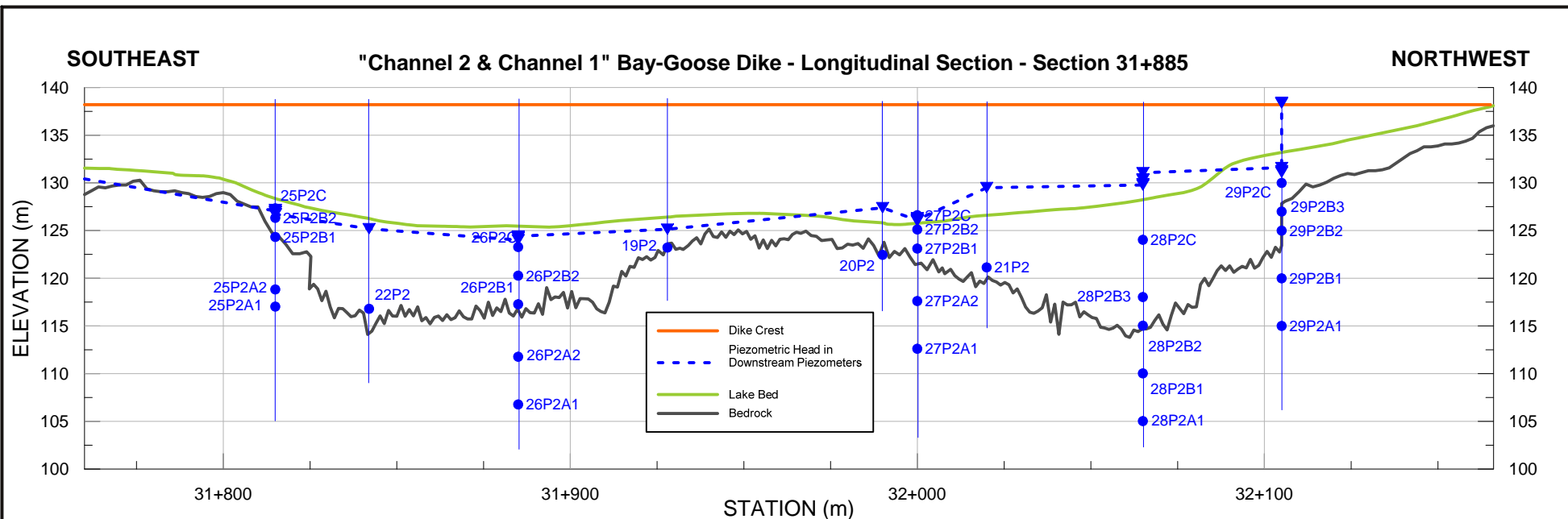

PROJECT					AGNICO EAGLE MINES LIMITED MEADOWBANK GOLD PROJECT NUNAVUT											
TITLE					BAYGOOSE DIKE Section 31+885 - CHANNEL 2, PIEZOMETRIC DATA (Aug 31/15 to Aug 31/16)											
PROJECT No.		PHASE No.			DESIGN		TD		28AUG14		SCALE		AS SHOWN		REV.	
CADD		TD		28AUG14		CHECK		PG		28AUG14		FIGURE 17				
REVIEW																



STATION 31+885

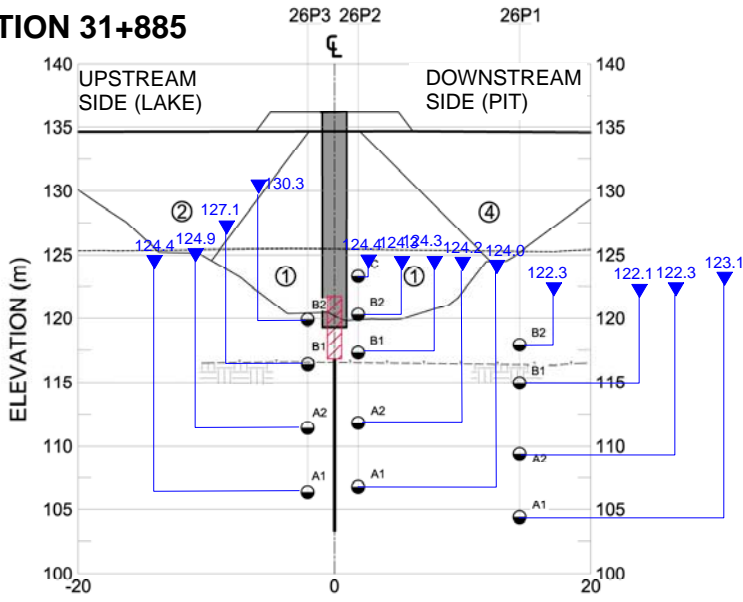

LEGEND

- CUTOFF (CSB)
- CUTOFF (SB)
- INITIAL ROCKFILL
- LAKEBED
- BEDROCK
- JET GROUT
- GROUT
- CORE BACKFILL (19 mm MINUS)
- COARSE BACKFILL (15mm MINUS)
- ROCKFILL
- FINE ROCKFILL
- TOTAL HEAD (m) ON July 7, 2015

VW Piezometer - Total Head

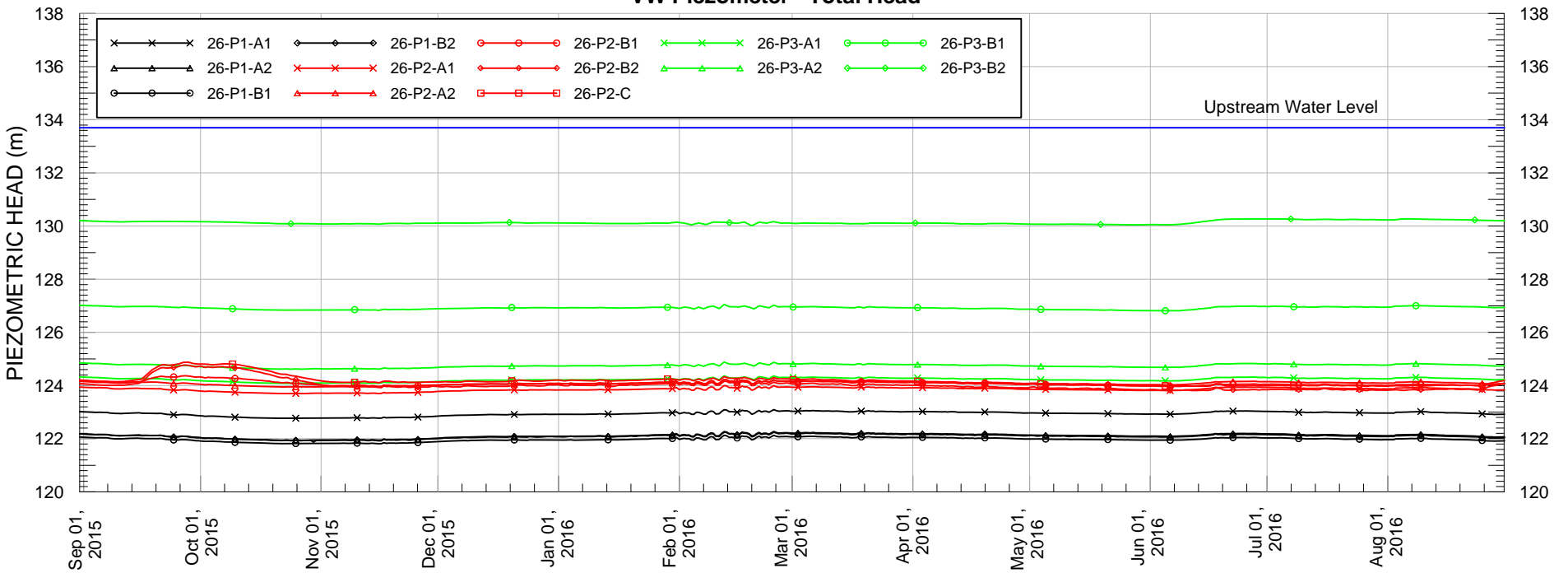

VW Piezometer - Temperature

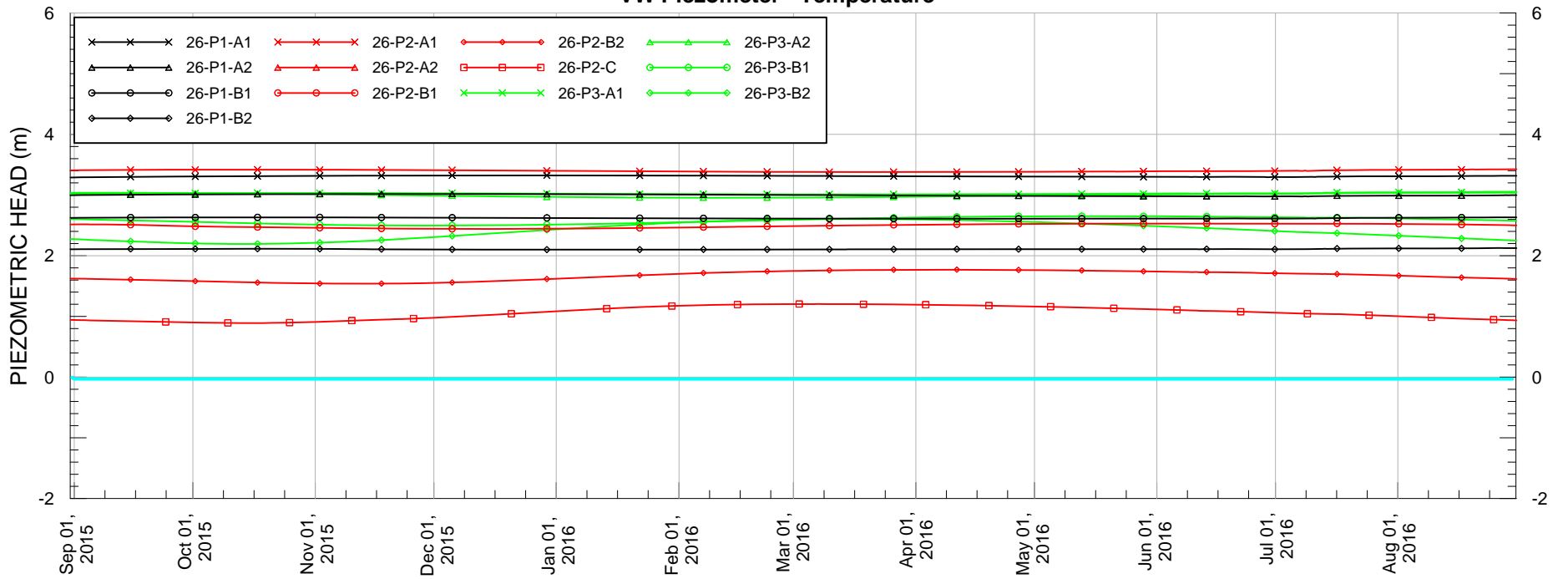

Air and Lake - Temperature

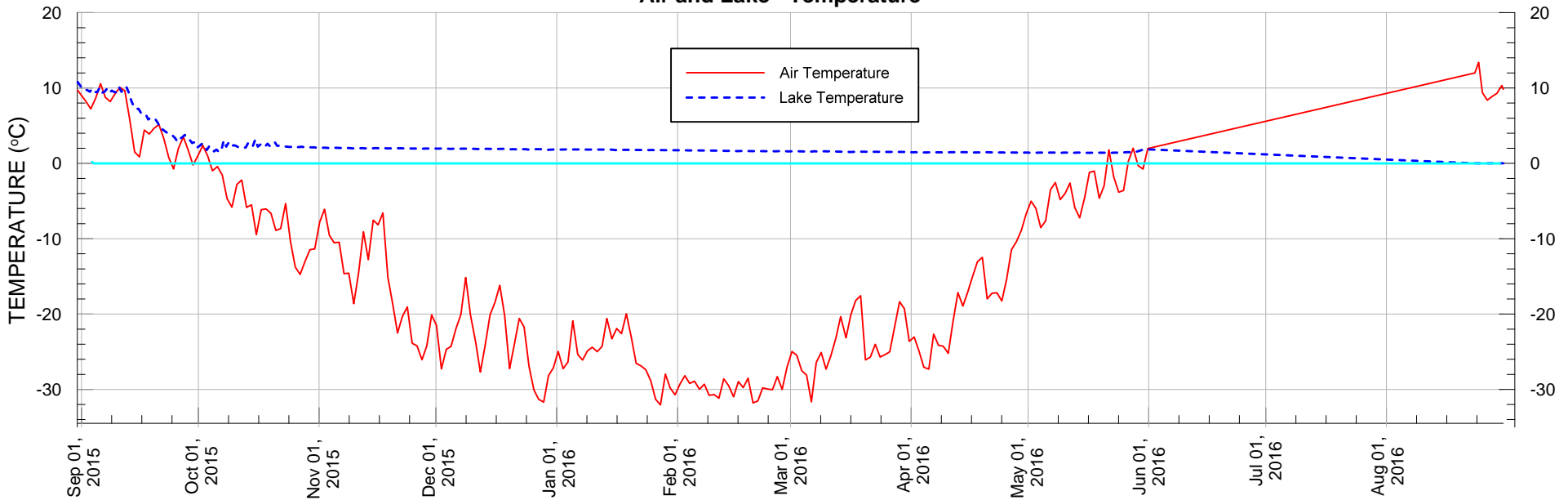

PROJECT					AGNICO EAGLE MINES LIMITED MEADOWBANK GOLD PROJECT NUNAVUT				
TITLE					BAYGOOSE DIKE - SECTION 31+885 PIEZOMETRIC DATA (Aug 31/15 to Aug 31/16)				
		PROJECT No.			PHASE No.				
		DESIGN	TD	28AUG14	SCALE	AS SHOWN	REV.		
		CADD	TD	28AUG14	FIGURE 18				
		CHECK	PG	28AUG14					
		REVIEW							

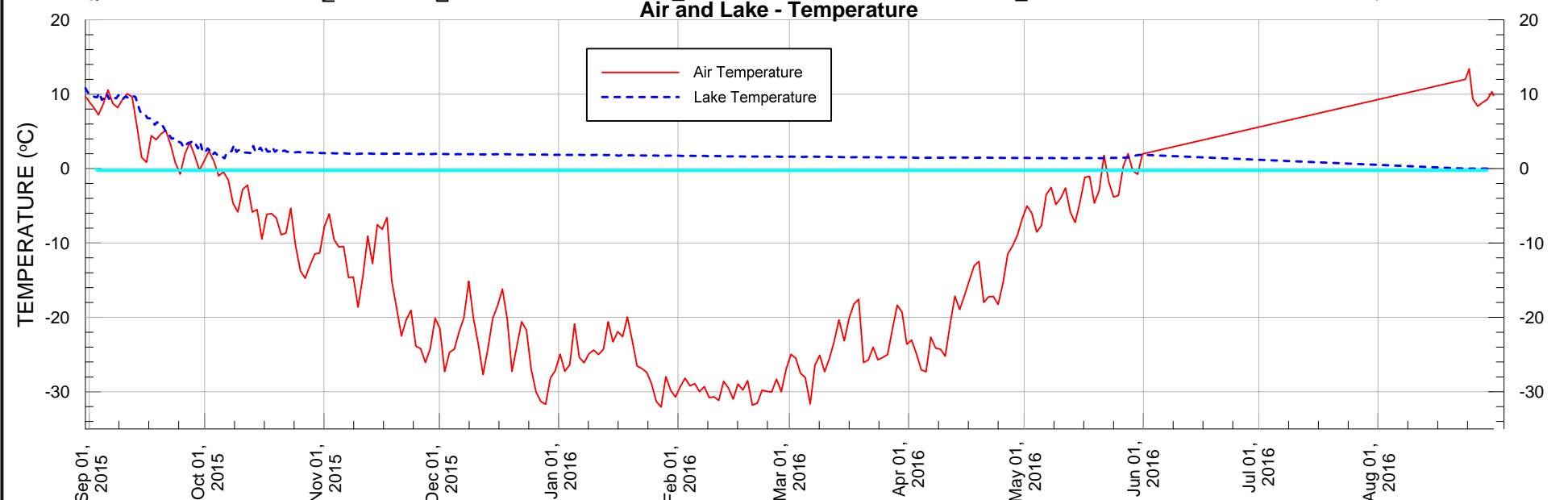
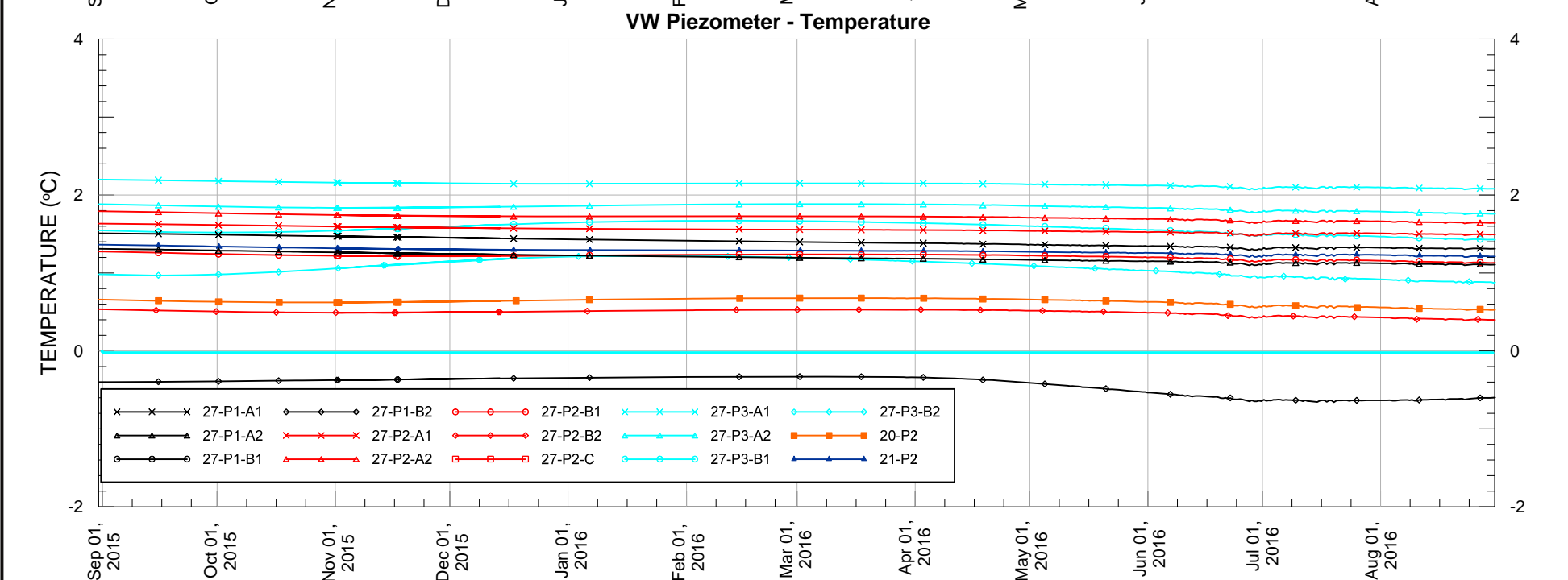
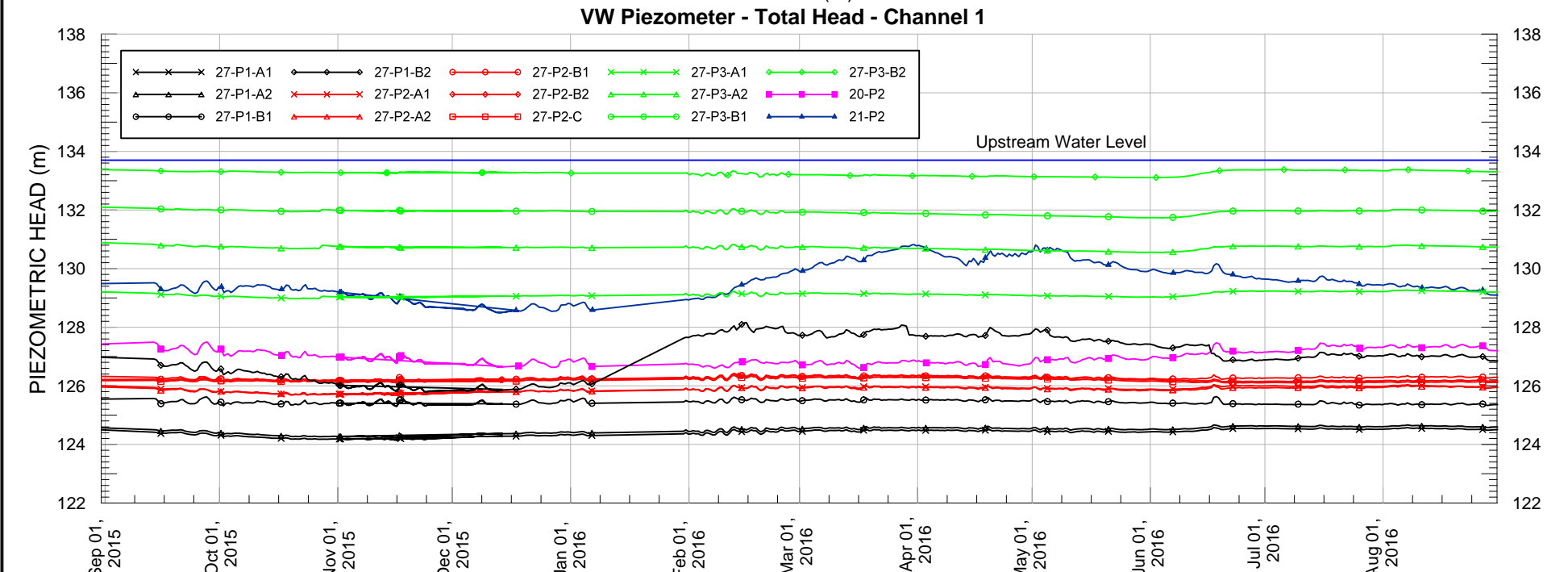
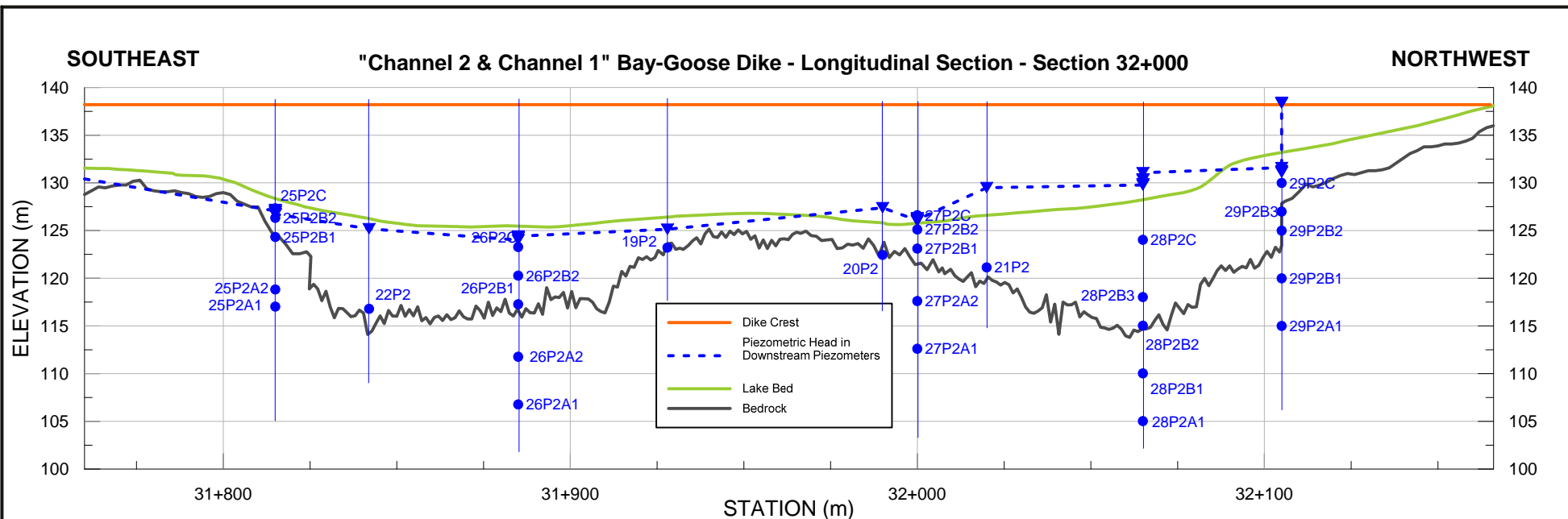

PROJECT		AGNICO EAGLE MINES LIMITED MEADOWBANK GOLD PROJECT NUNAVUT		
TITLE		BAYGOOSE DIKE CHANNEL 1, PIEZOMETRIC DATA SECTION 32+000 (Aug 31/15 to Aug 31/16)		
	PROJECT No.	PHASE No.		
	DESIGN TD 28AUG14	SCALE	AS SHOWN	
	CADD TD 28AUG14	REV.		
	CHECK PG 28AUG14	FIGURE 19		
REVIEW				

STATION 32+000

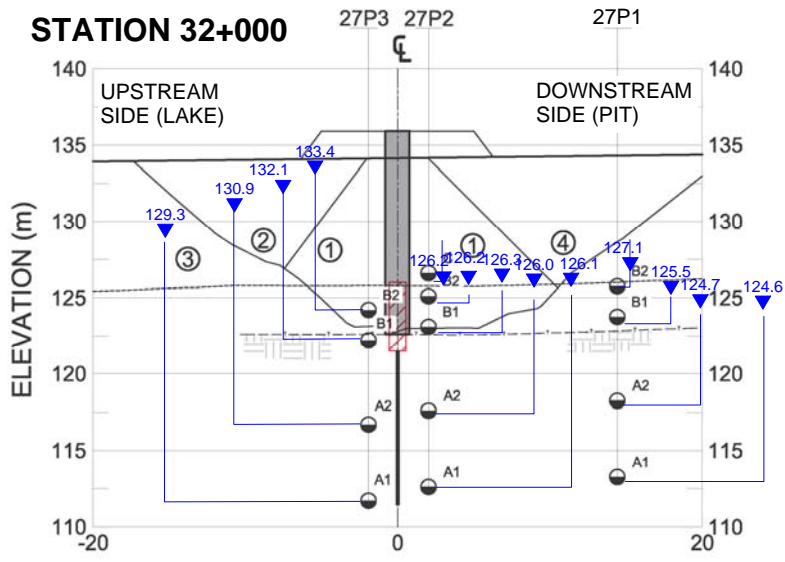

LEGEND

- CUTOFF (CSB)
- CUTOFF (SB)
- INITIAL ROCKFILL
- LAKEBED
- BEDROCK
- JET GROUT
- GROUT
- CORE BACKFILL (19 mm MINUS)
- COARSE BACKFILL (15mm MINUS)
- ROCKFILL
- FINE ROCKFILL
- TOTAL HEAD (m) ON July 7, 2015

VW Piezometer - Total Head

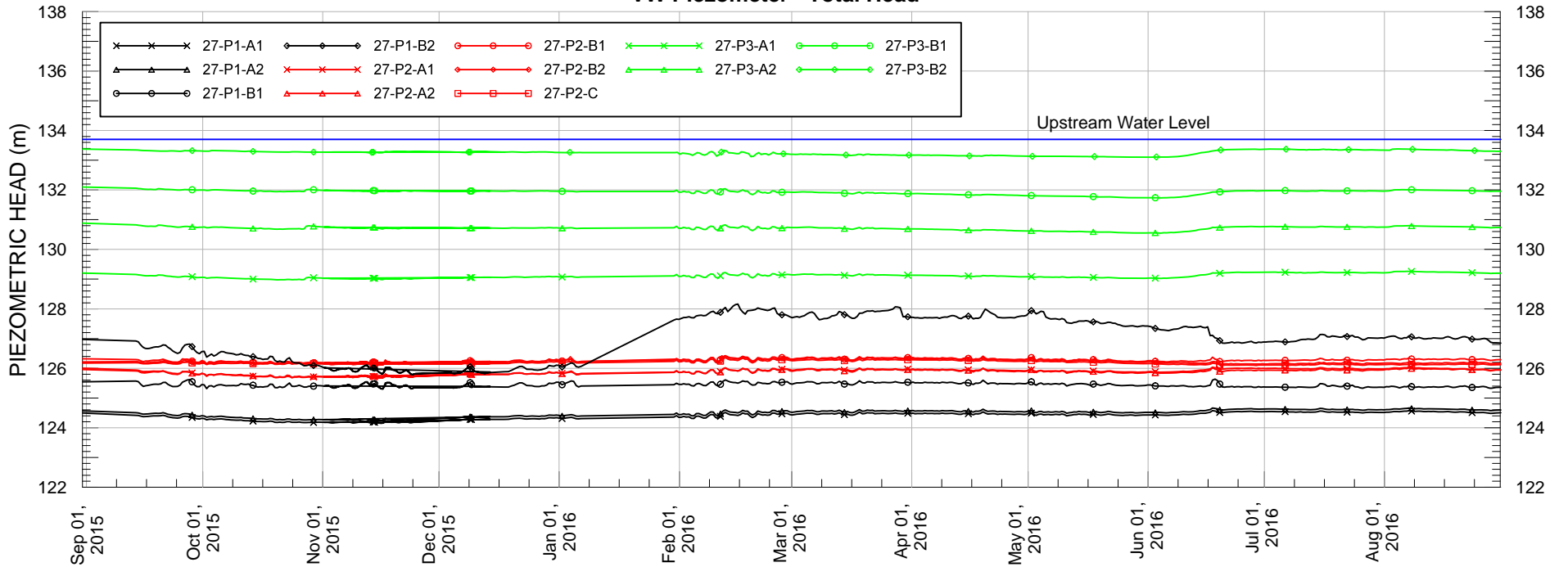

VW Piezometer - Temperature

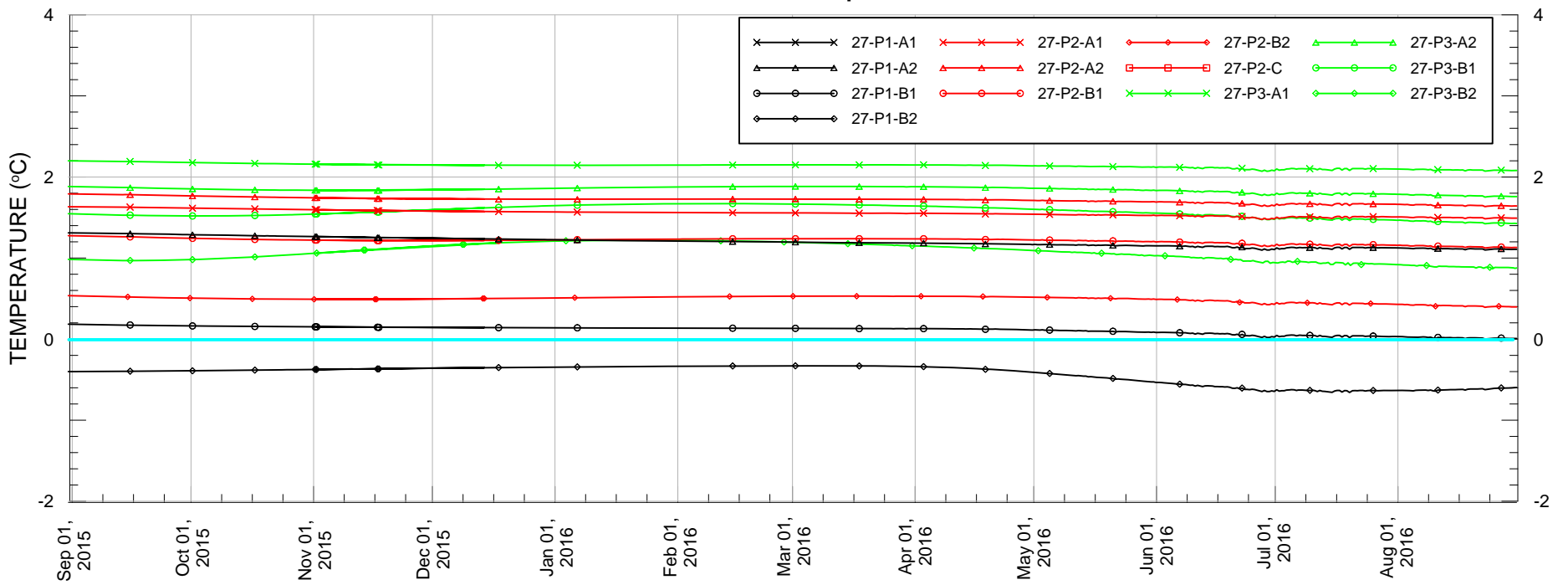

Air and Lake - Temperature

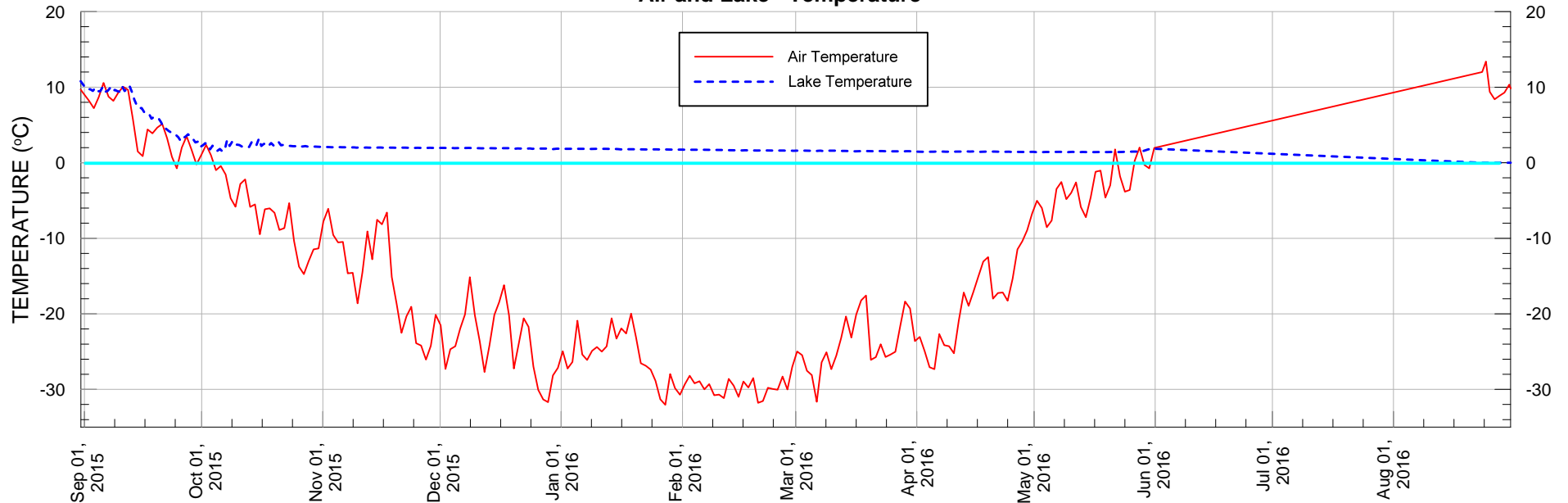

PROJECT				AGNICO EAGLE MINES LIMITED MEADOWBANK GOLD PROJECT NUNAVUT			
TITLE				BAY OOSE DIKE - SECTION 32+000 PIEZOMETRIC DATA (Aug 31/15 to Aug 31/16)			
		PROJECT No.	PHASE No.				
		DESIGN TD	28AUG14	SCALE	AS SHOWN	REV.	
		CADD TD	28AUG14				
		CHECK PG	28AUG14				
		REVIEW					
FIGURE 20							

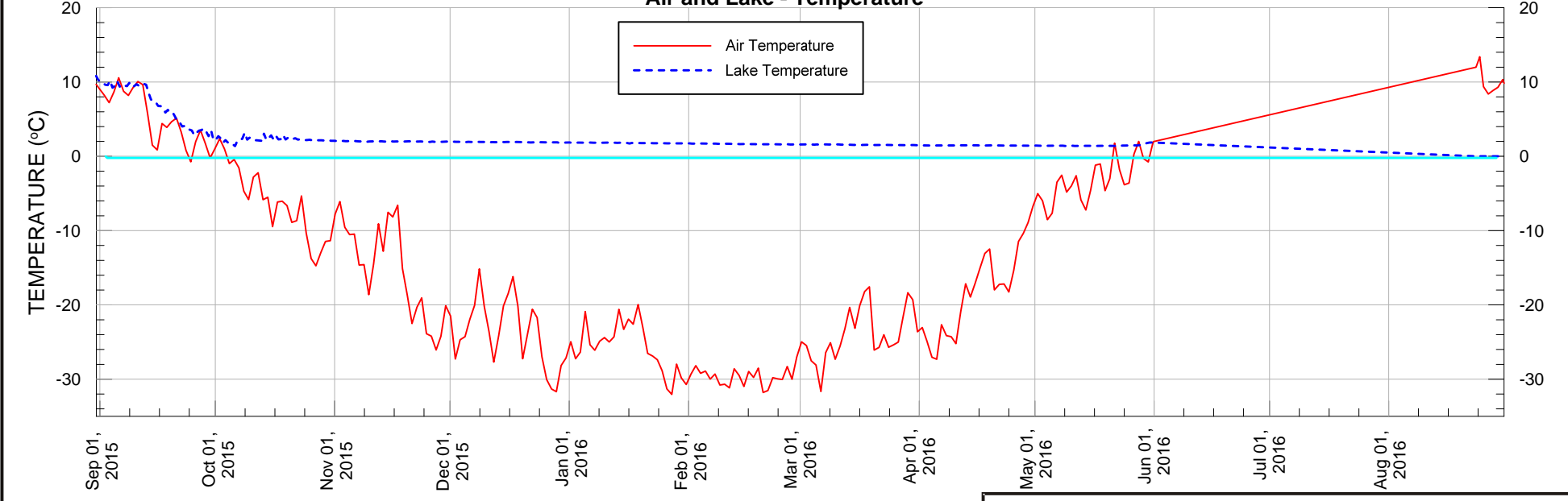
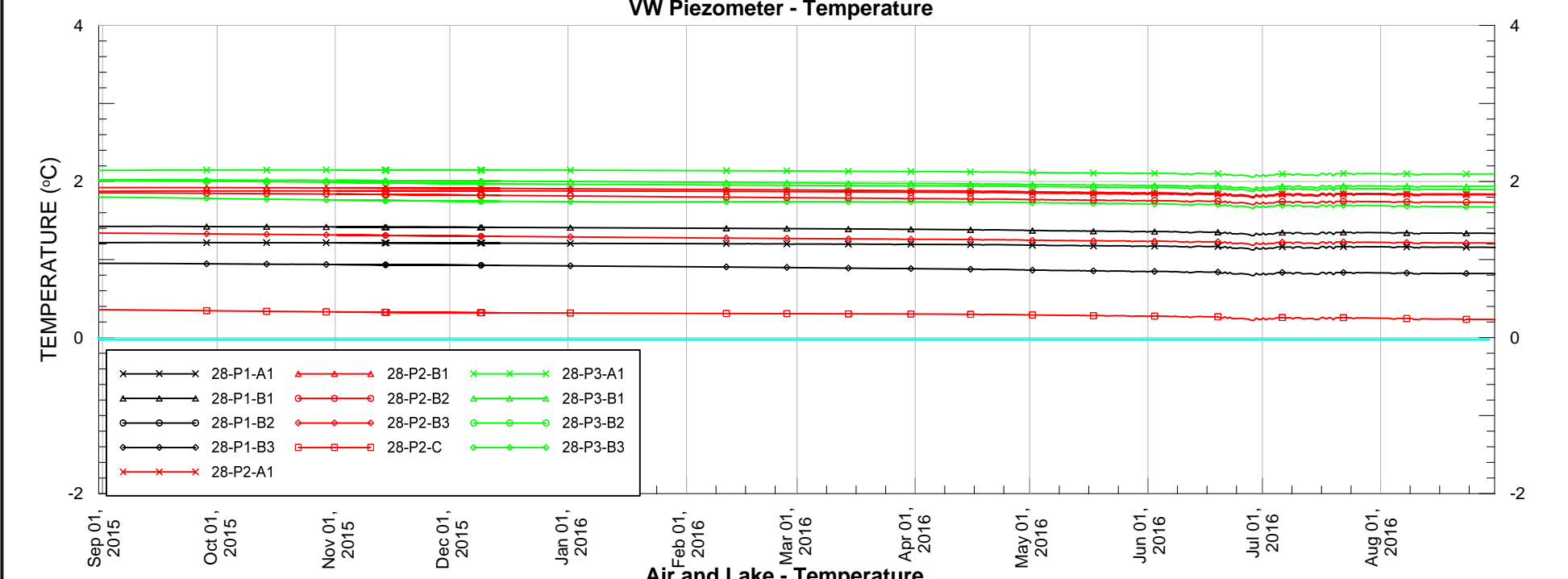
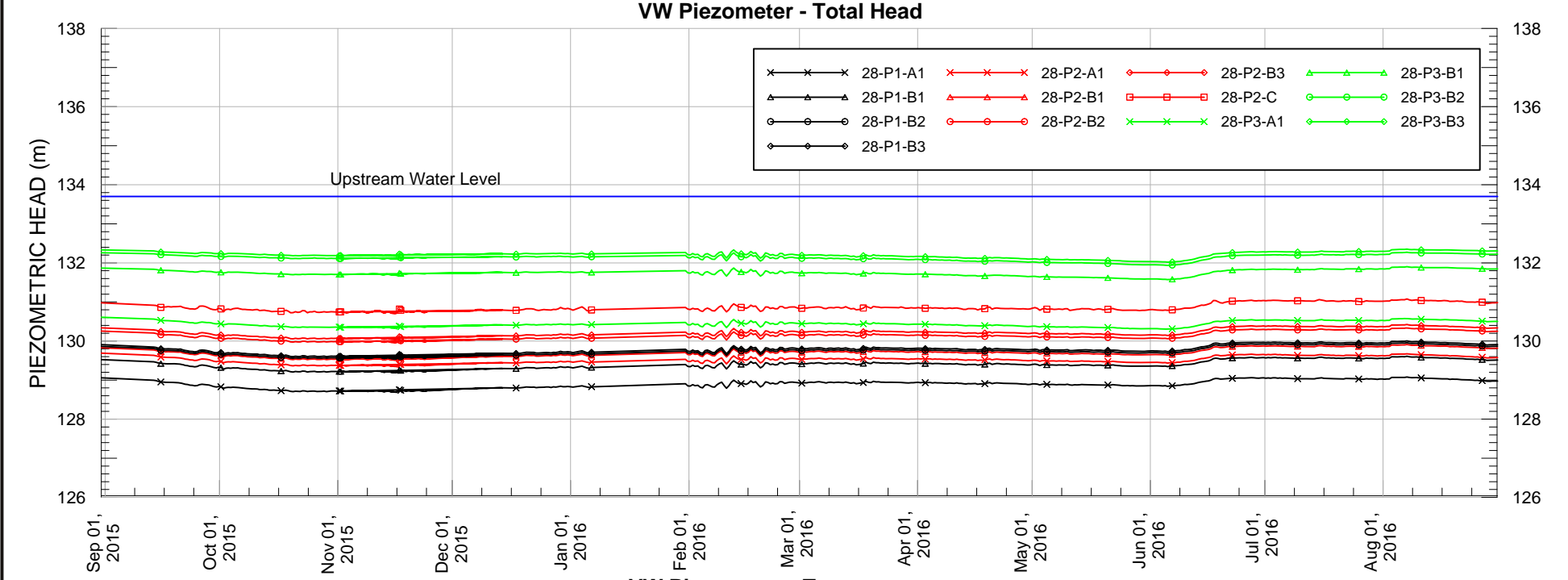
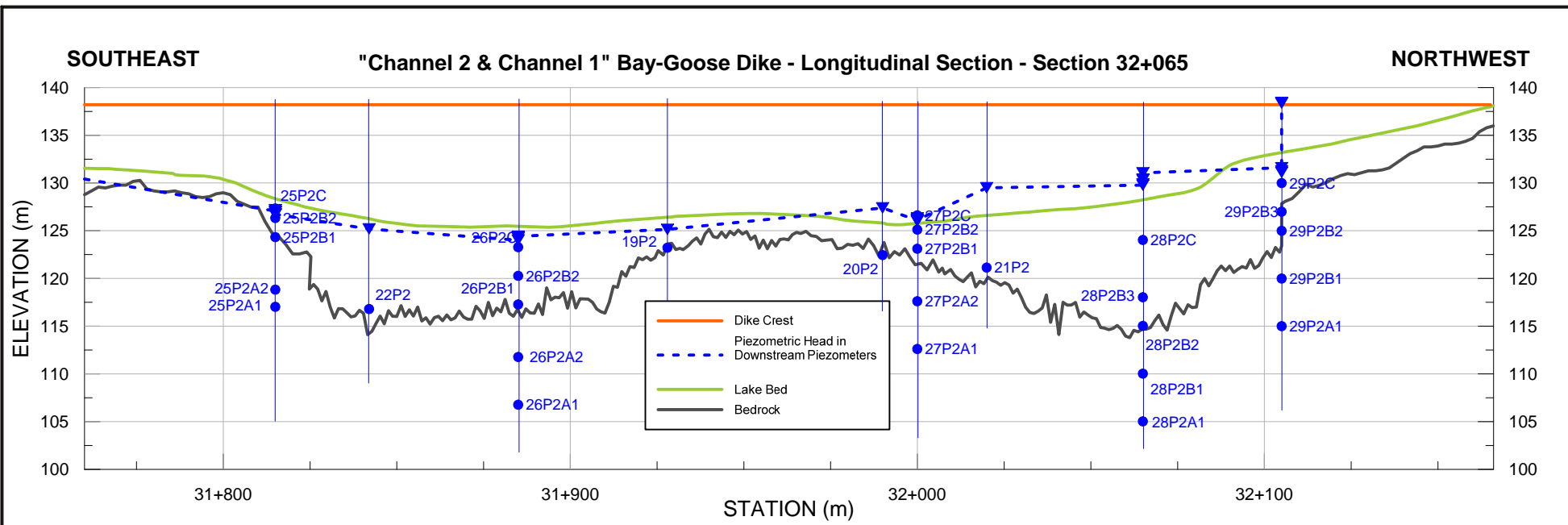

PROJECT		AGNICO EAGLE MINES LIMITED MEADOWBANK GOLD PROJECT NUNAVUT			
TITLE		BAYGOOSE DIKE Section 32+065 - CHANNEL 1, PIEZOMETRIC DATA (Aug 31/15 to Aug 31/16)			
	PROJECT No.	PHASE No.		FIGURE 21	
	DESIGN TD	28AUG14	SCALE AS SHOWN		REV.
	CADD TD	28AUG14			
	CHECK PG	28AUG14			
REVIEW					

STATION 32+065

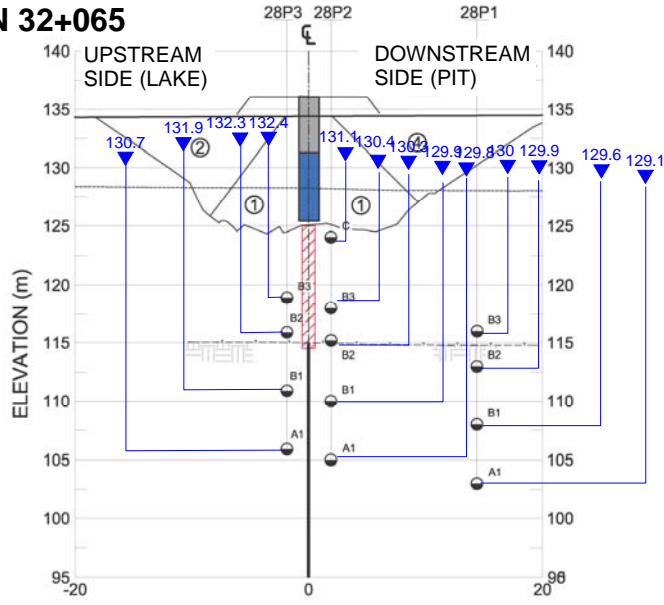

LEGEND

- CUTOFF (CSB)
- CUTOFF (SB)
- INITIAL ROCKFILL
- LAKEBED
- BEDROCK
- JET GROUT
- GROUT
- CORE BACKFILL (19 mm MINUS)
- COARSE BACKFILL (15mm MINUS)
- ROCKFILL
- FINE ROCKFILL
- TOTAL HEAD (m) ON July 7, 2015

VW Piezometer - Total Head

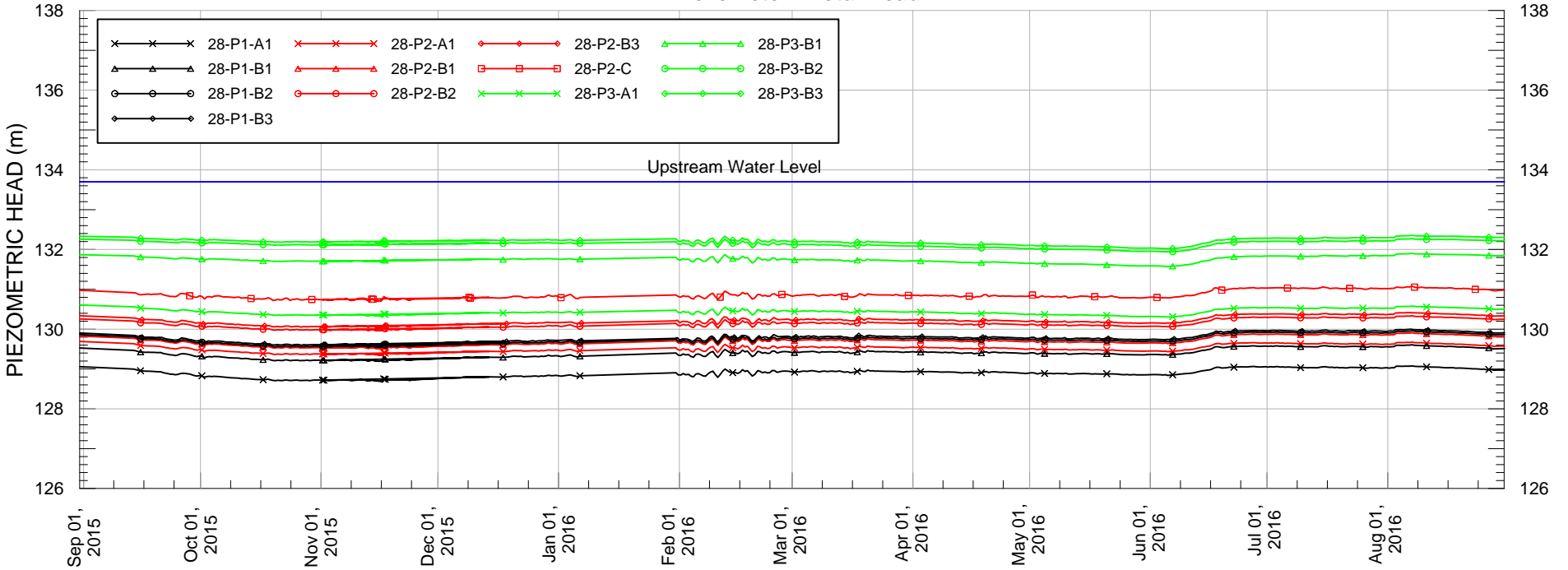

VW Piezometer - Temperature

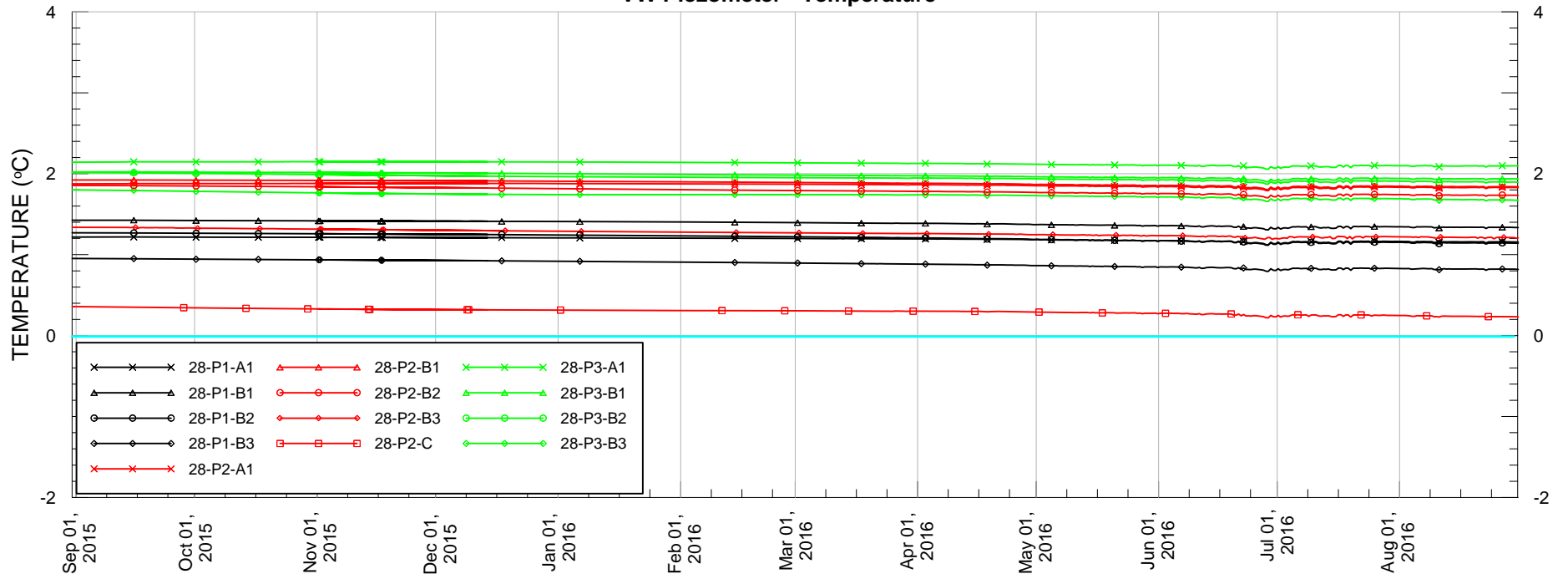

Air and Lake - Temperature

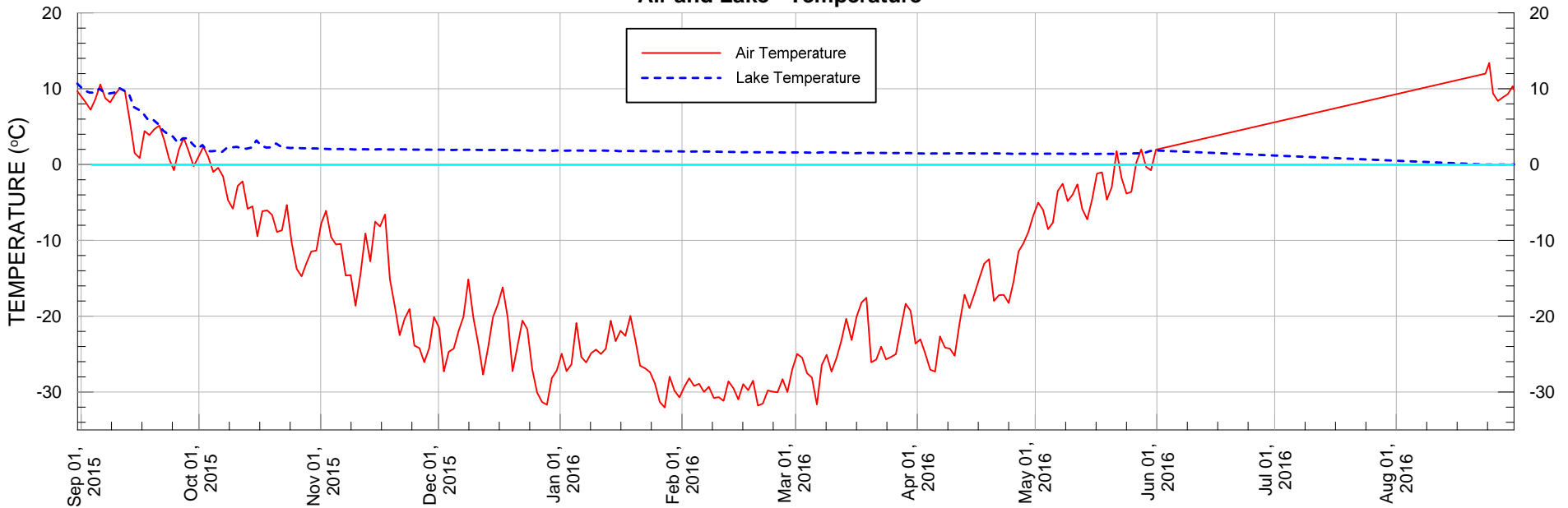

PROJECT				AGNICO EAGLE MINES LIMITED MEADOWBANK GOLD PROJECT NUNAVUT			
TITLE				BAYGOOSE DIKE - SECTION 32+065 PIEZOMETRIC DATA (Aug 31/15 to Aug 31/16)			
PROJECT No.		28AUG14		PHASE No.		AS SHOWN	
DESIGN	ID	28AUG14	SCALE	AS SHOWN	REV.		
CADD	ID	28AUG14	FIGURE 22				
CHECK	PG	28AUG14					
REVIEW							



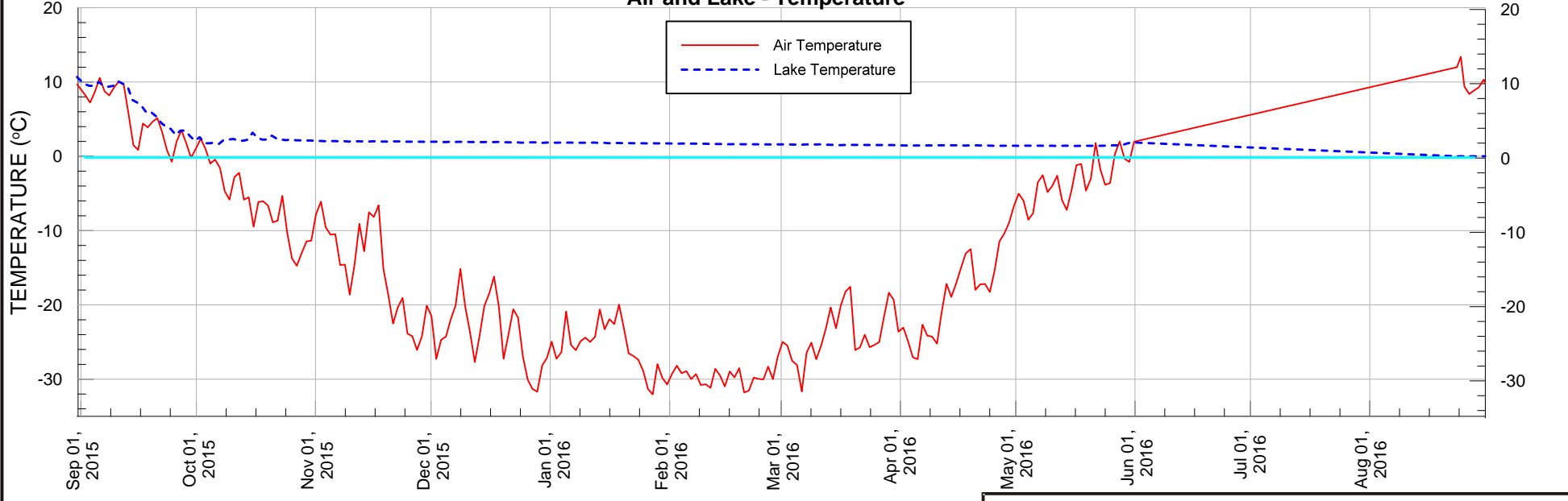
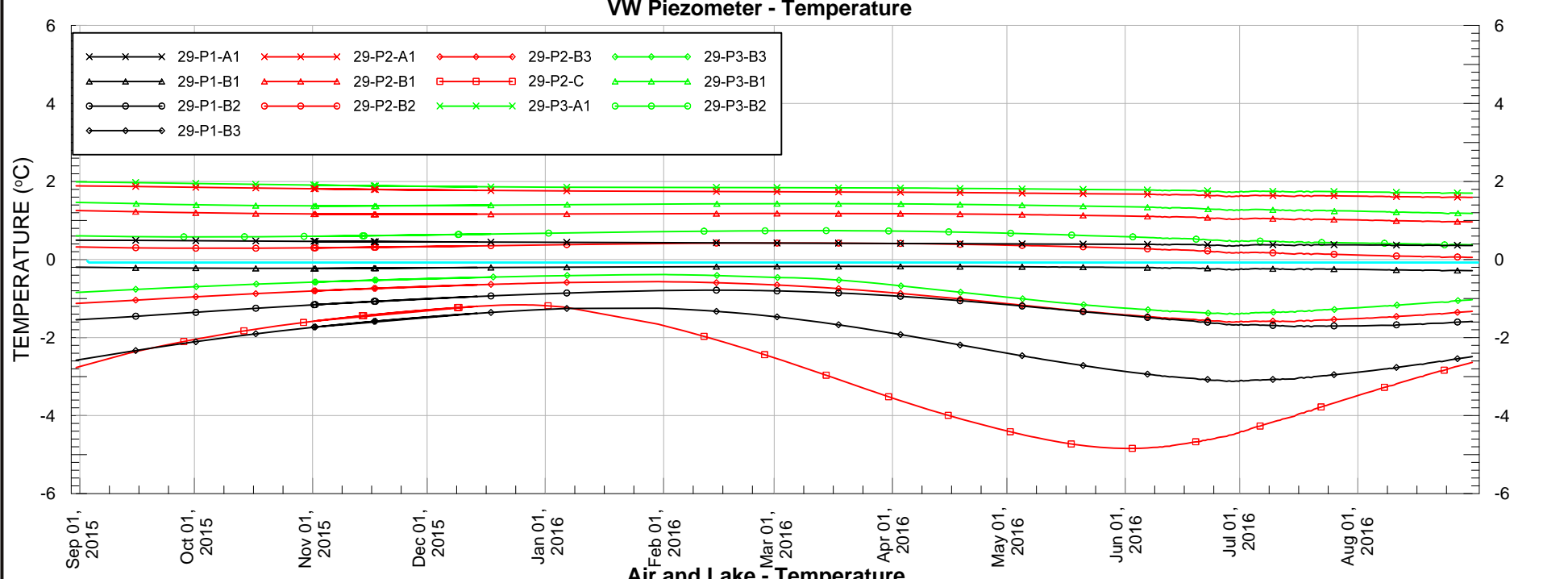
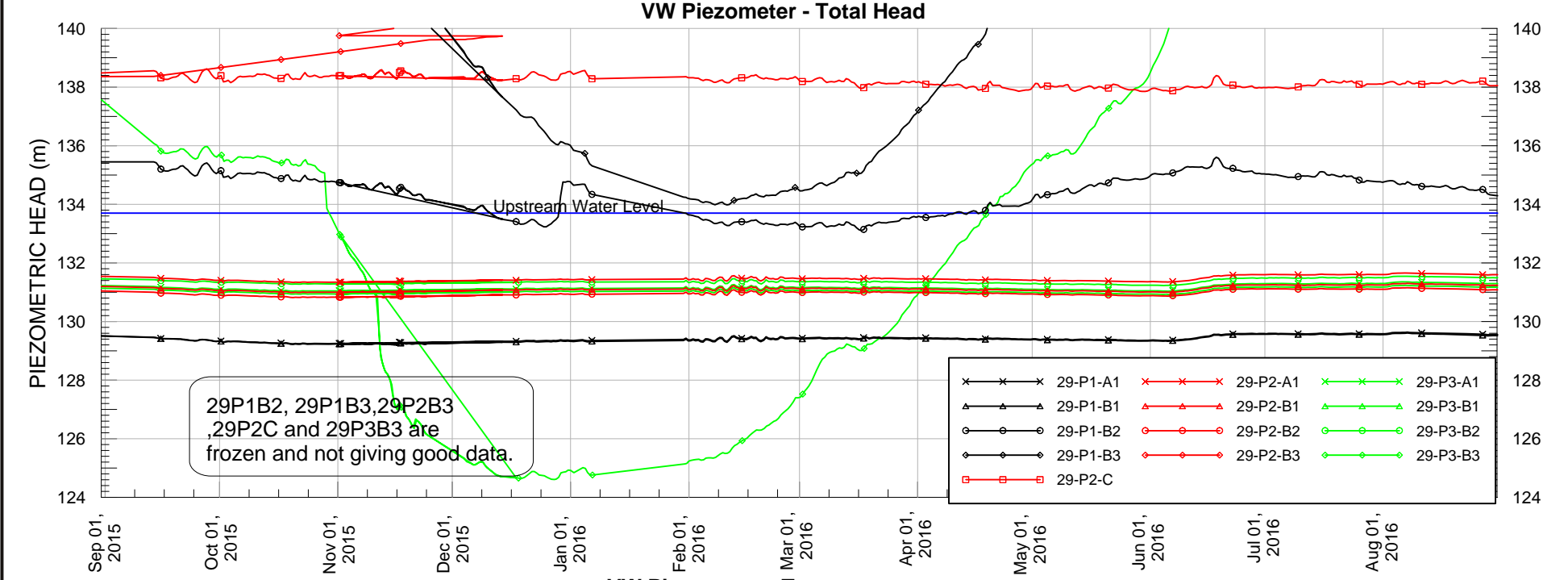
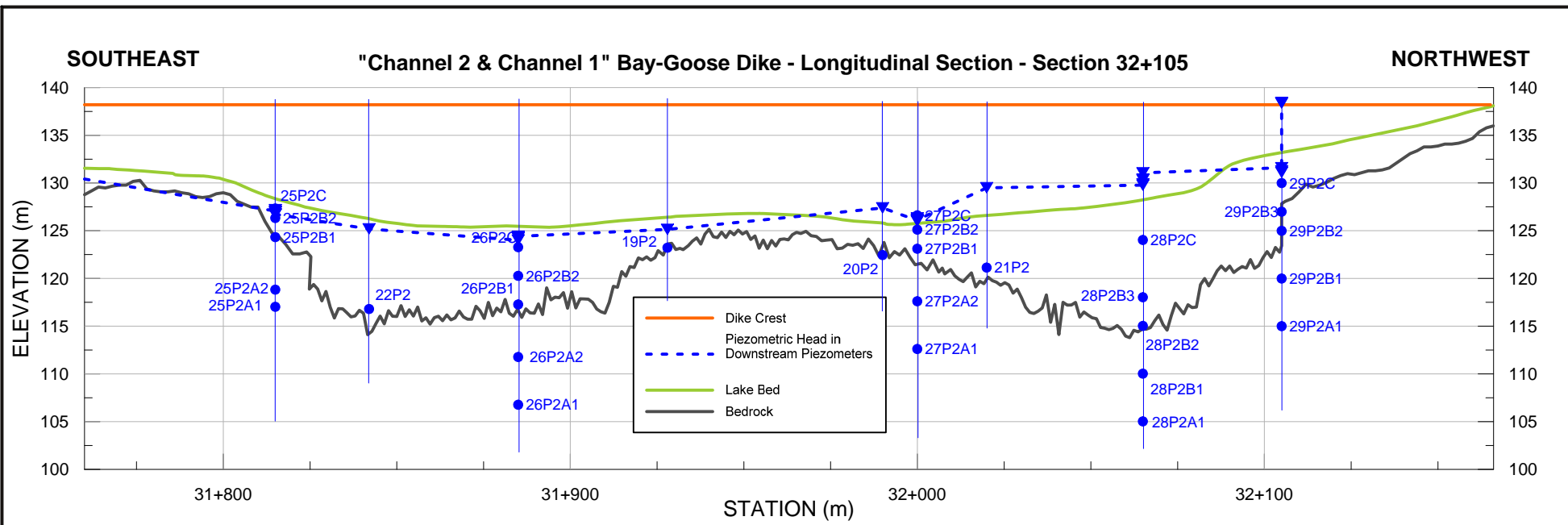

PROJECT				AGNICO EAGLE MINES LIMITED MEADOWBANK GOLD PROJECT NUNAVUT			
TITLE				BAYGOOSE DIKE Station 32+105 - CHANNEL 1, PIEZOMETRIC DATA (Aug 31/15 to Aug 31/16)			
PROJECT No.		PHASE No.		DESIGN		SCALE AS SHOWN	
28AUG14		REV.		TD		28AUG14	
CADD		CHECK		PG		28AUG14	
REVIEW		AGNICO EAGLE MEADOWBANK		FIGURE 23			

STATION 32+105

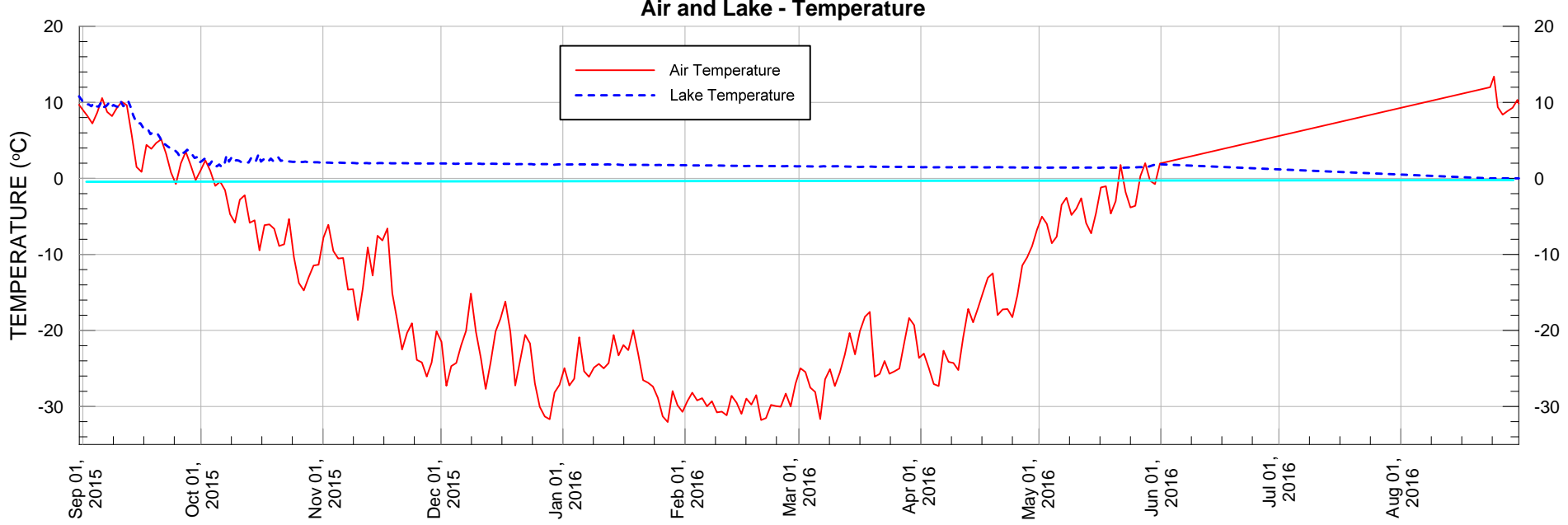
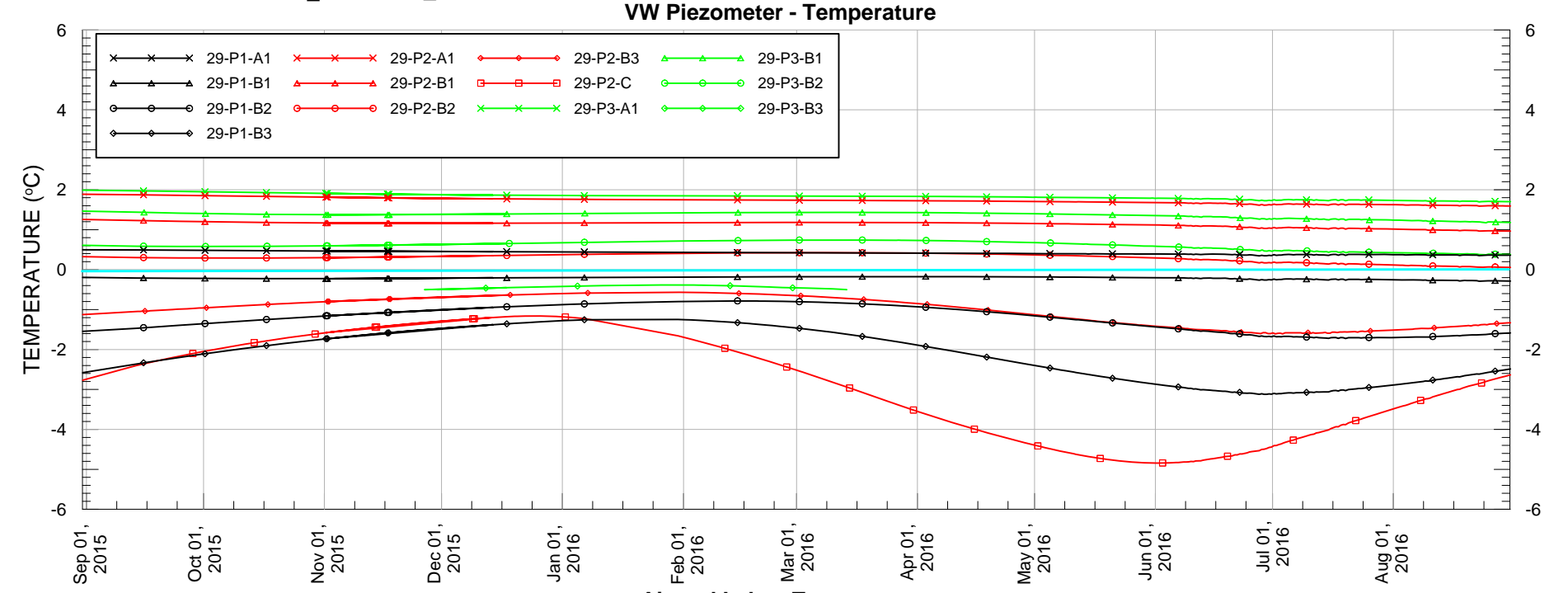
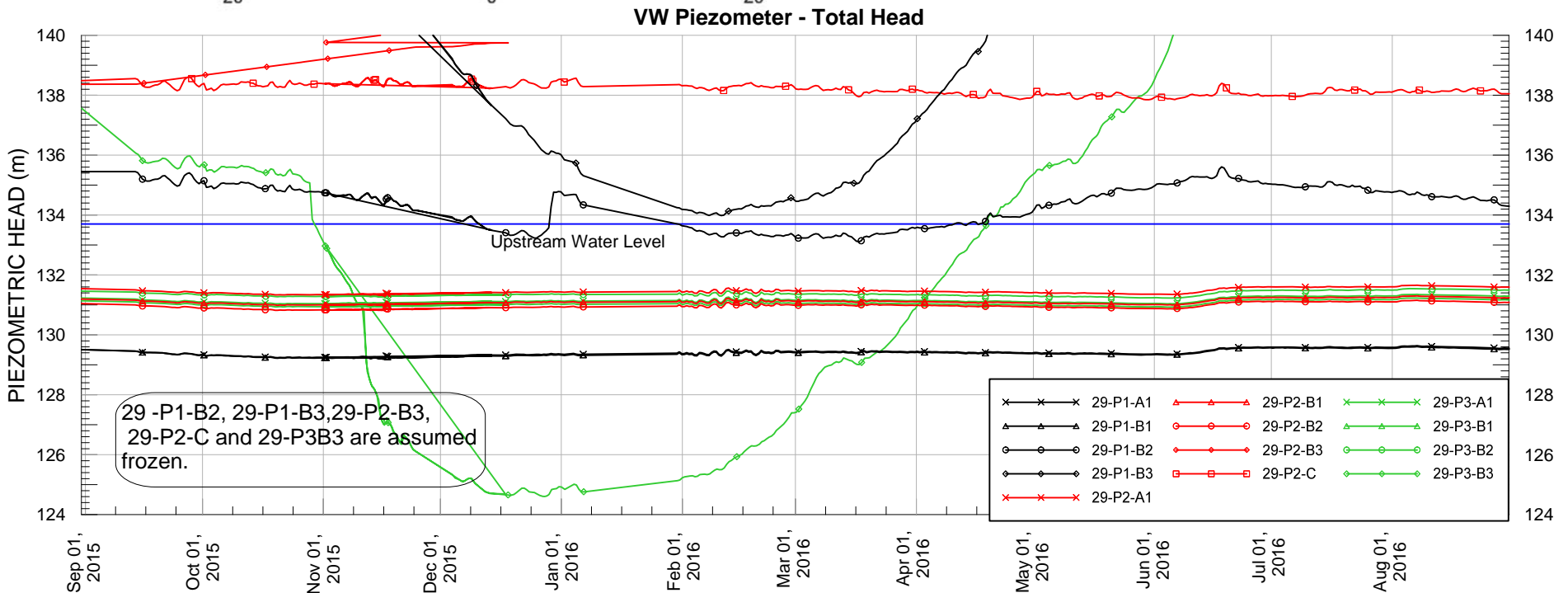
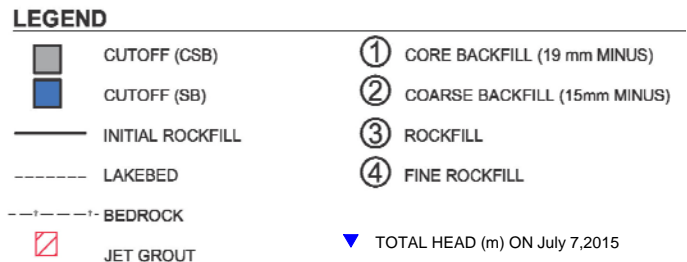
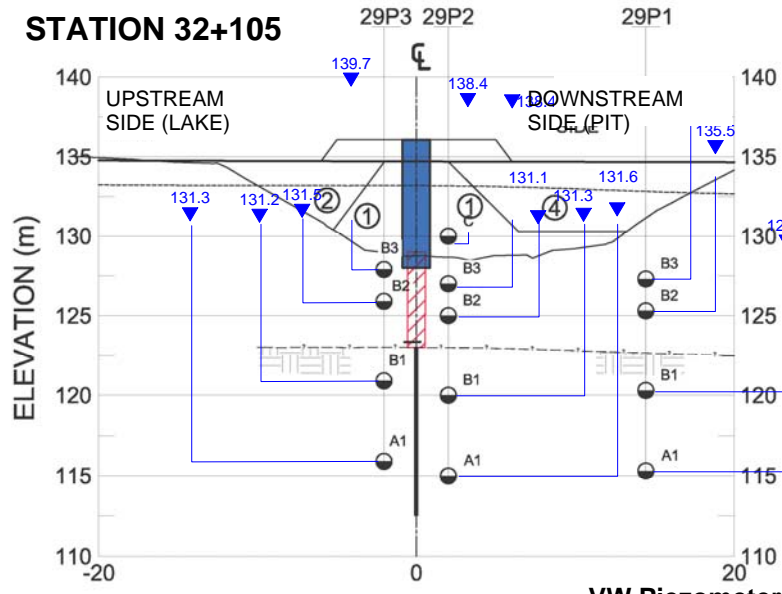

PROJECT			
AGNICO EAGLE MINES LIMITED MEADOWBANK GOLD PROJECT NUNAVUT			
TITLE			
BAYGOOSE DIKE - SECTION 32+105 PIEZOMETRIC DATA (Aug 31/15 to Aug 31/16)			
	PROJECT No.		PHASE No.
	DESIGN	TD 28AUG14	SCALE AS SHOWN
	CADD	TD 28AUG14	REV.
	CHECK	PG 28AUG14	FIGURE 24
REVIEW			

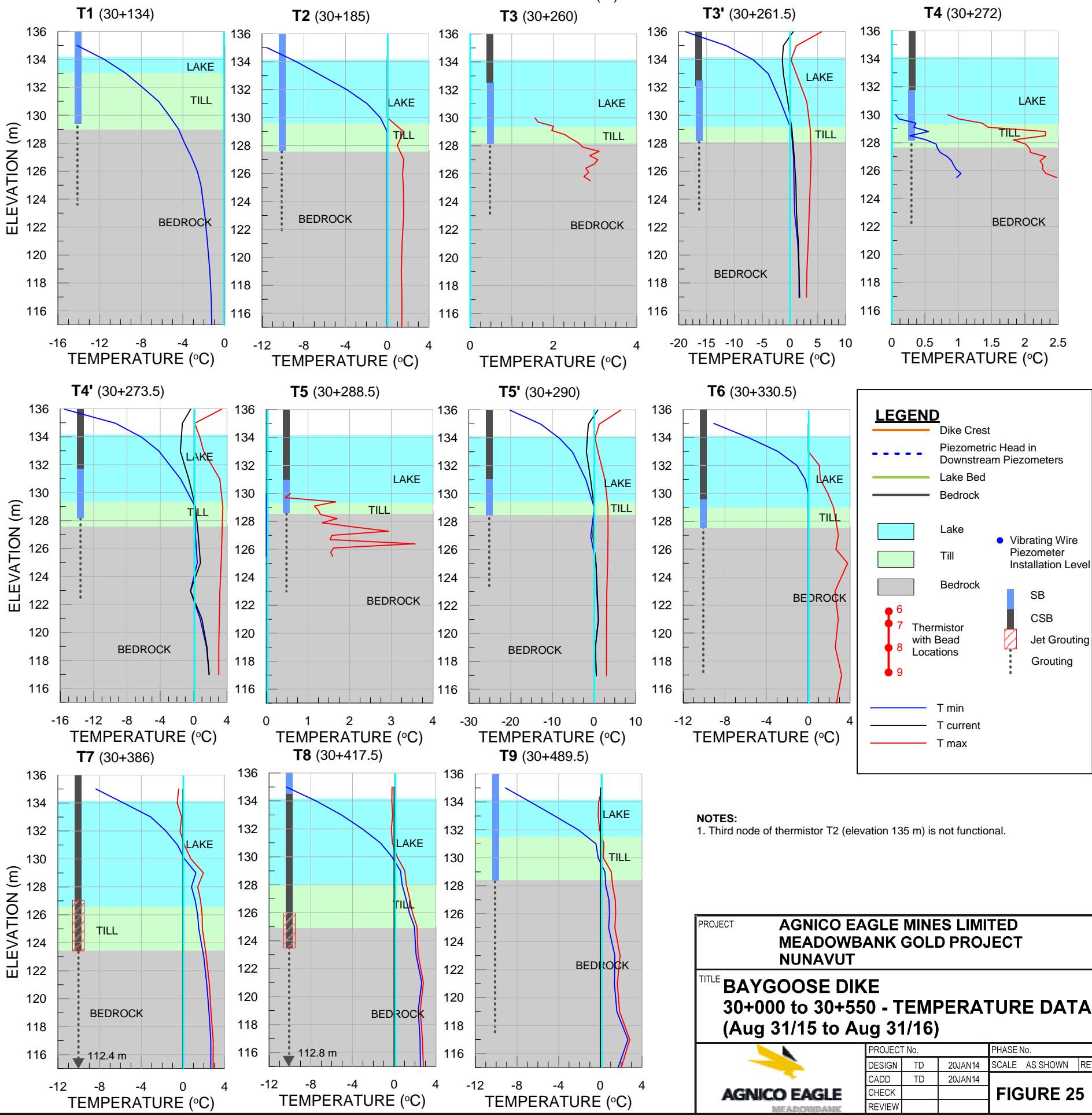
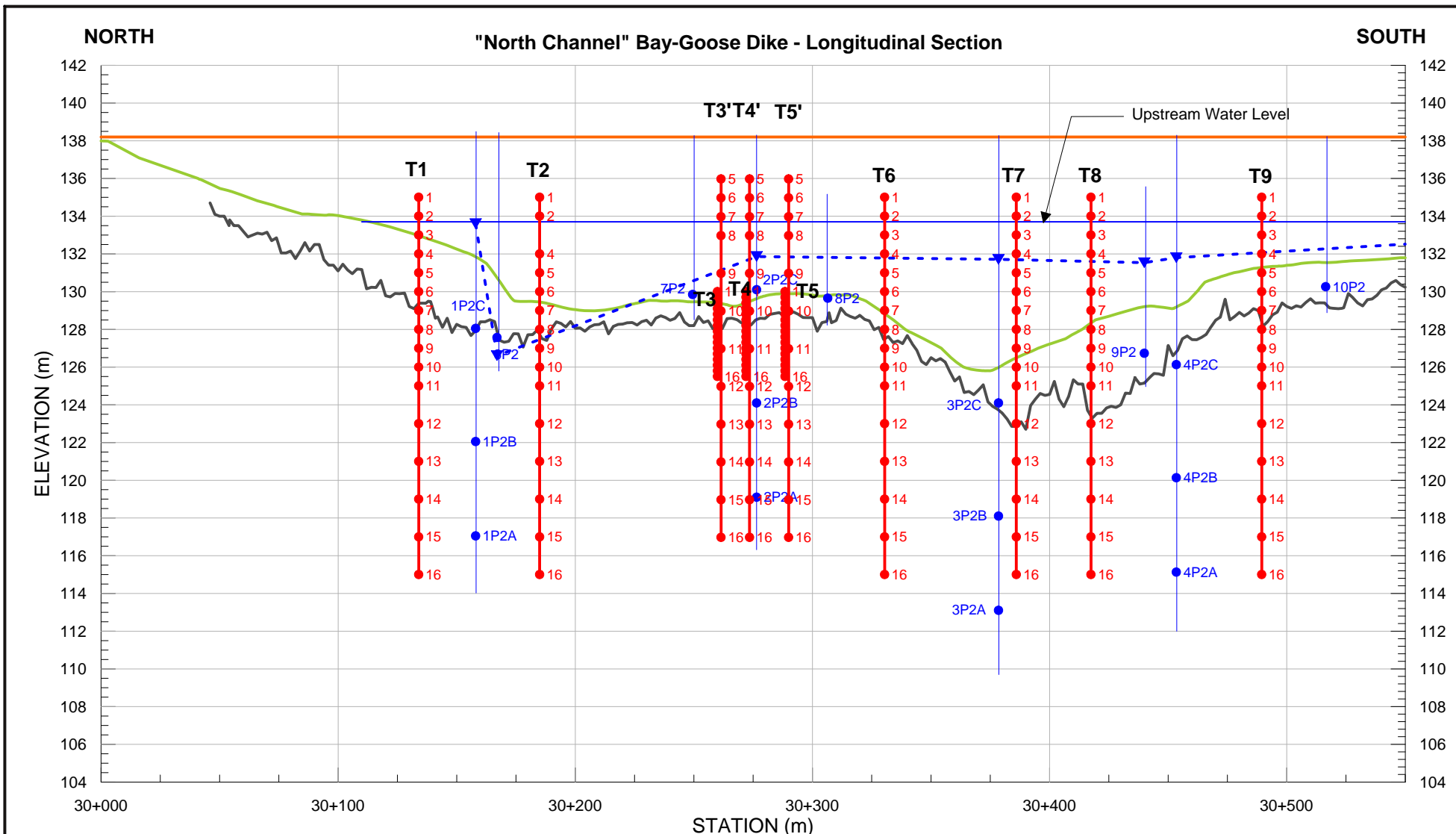

PROJECT			
AGNICO EAGLE MINES LIMITED MEADOWBANK GOLD PROJECT NUNAVUT			
TITLE			
BAYGOOSE DIKE 30+000 to 30+550 - TEMPERATURE DATA (Aug 31/15 to Aug 31/16)			
PROJECT No.		PHASE No.	
DESIGN	TD	20JAN14	SCALE AS SHOWN
CADD	TD	20JAN14	REV.
CHECK			
REVIEW			
AGNICO EAGLE <small>MEADOWBANK</small>			FIGURE 25

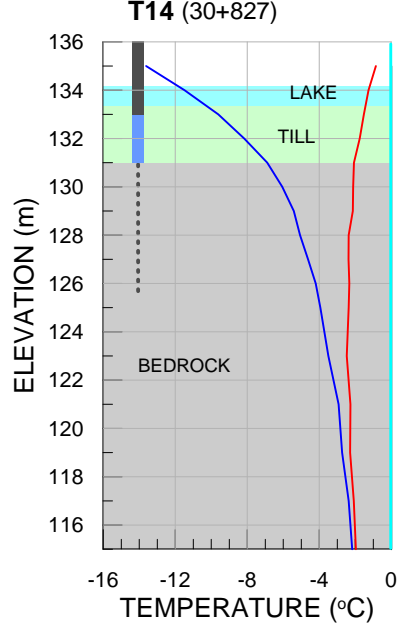
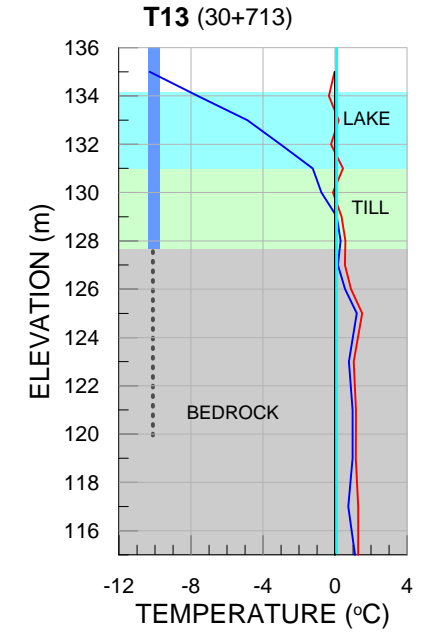
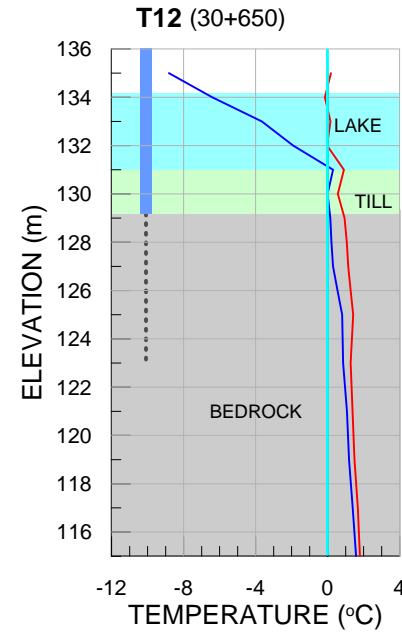
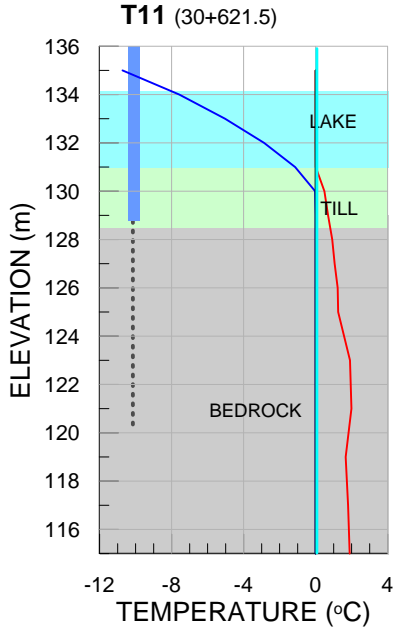
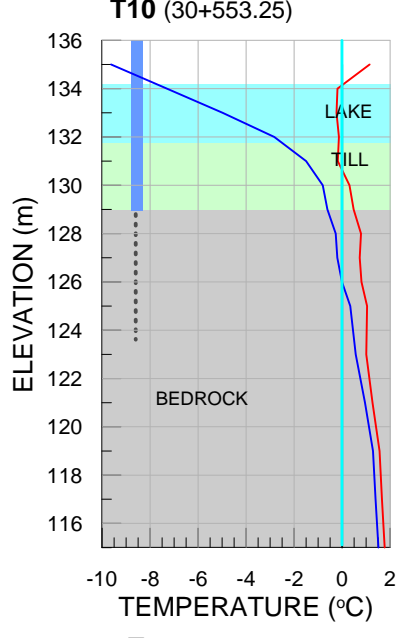
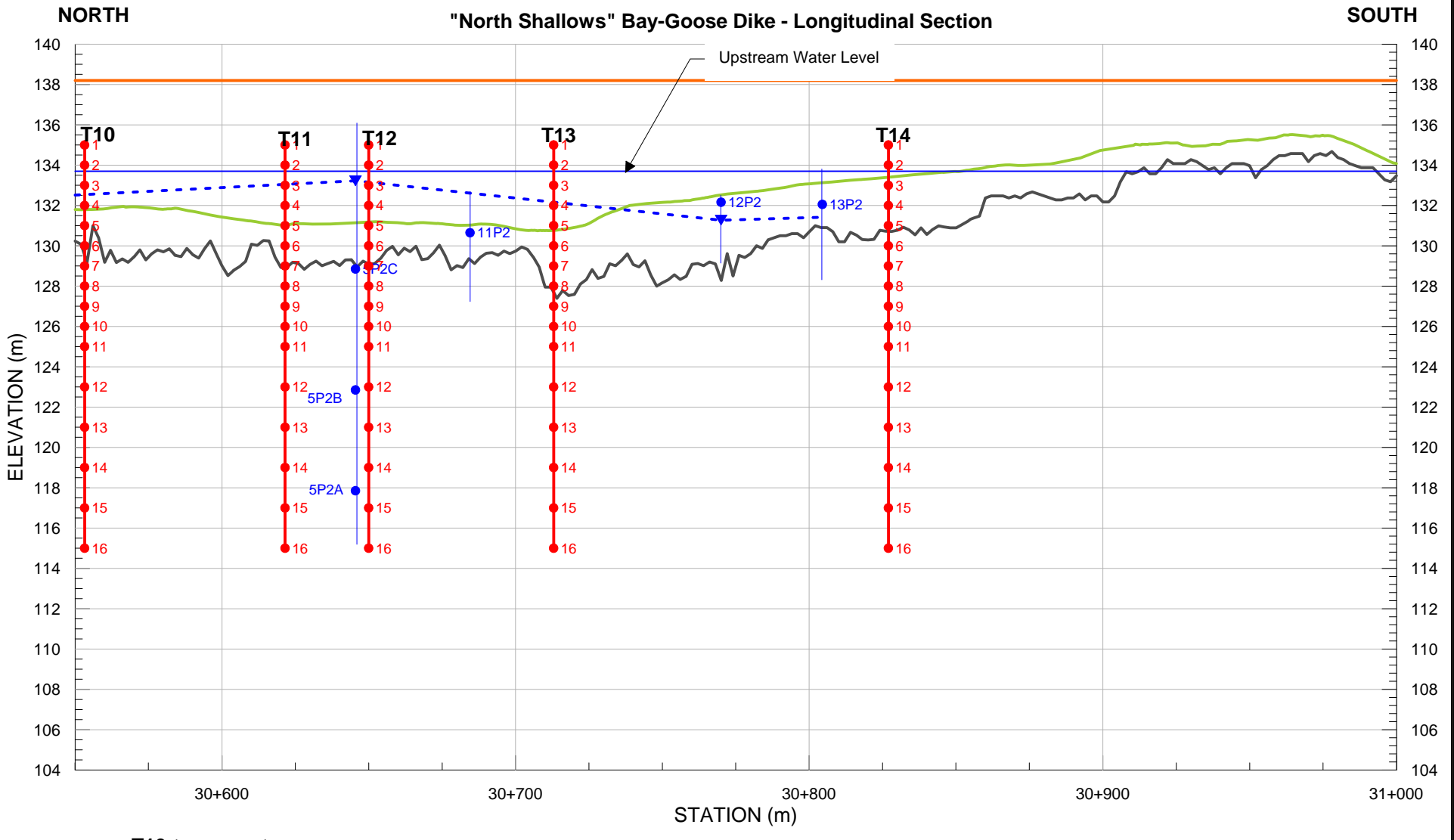

LEGEND

- Dike Crest
- - - Piezometric Head in Downstream Piezometers
- Lake Bed
- Bedrock
- █ Lake
- █ Till
- █ Bedrock
- Thermistor with Bead Locations
- T min
- T current
- T max
- Vibrating Wire Piezometer Installation Level
- █ SB
- █ CSB
- █ Jet Grouting
- █ Grouting

PROJECT		AGNICO EAGLE MINES LIMITED MEADOWBANK GOLD PROJECT NUNAVUT				
TITLE		BAYGOOSE DIKE 30+550 to 31+000 - TEMPERATURE DATA (Aug 31/15 to Aug 31/16)				
		PROJECT No.		PHASE No.		
		DESIGN	TD	20JAN14	SCALE AS SHOWN	REV.
		CADD	TD	20JAN14	FIGURE 26	
		CHECK				
REVIEW						

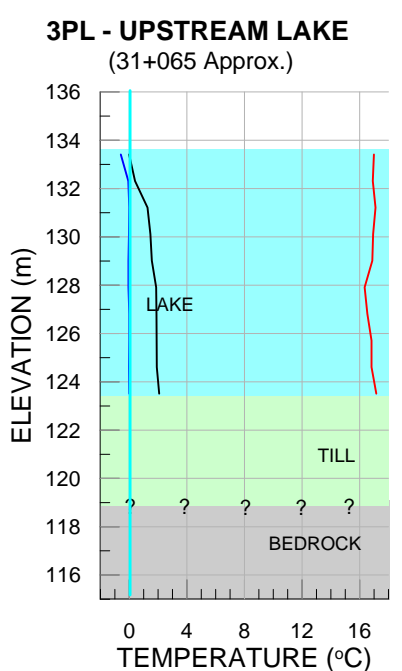
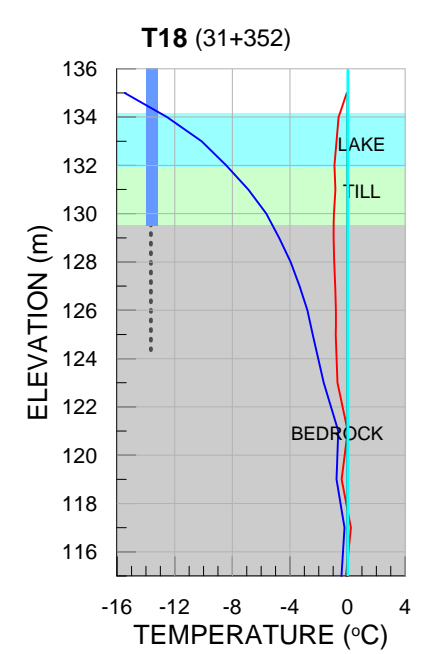
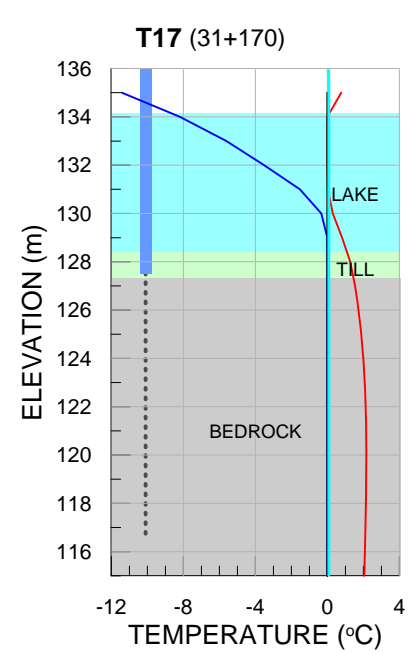
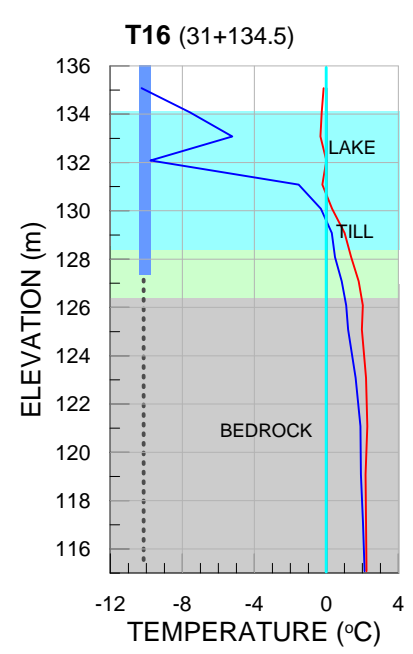
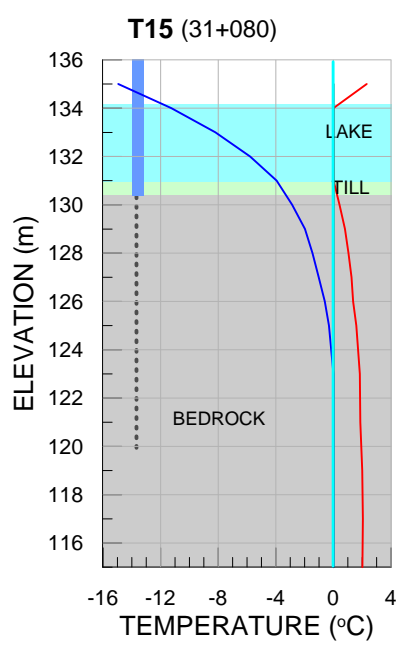
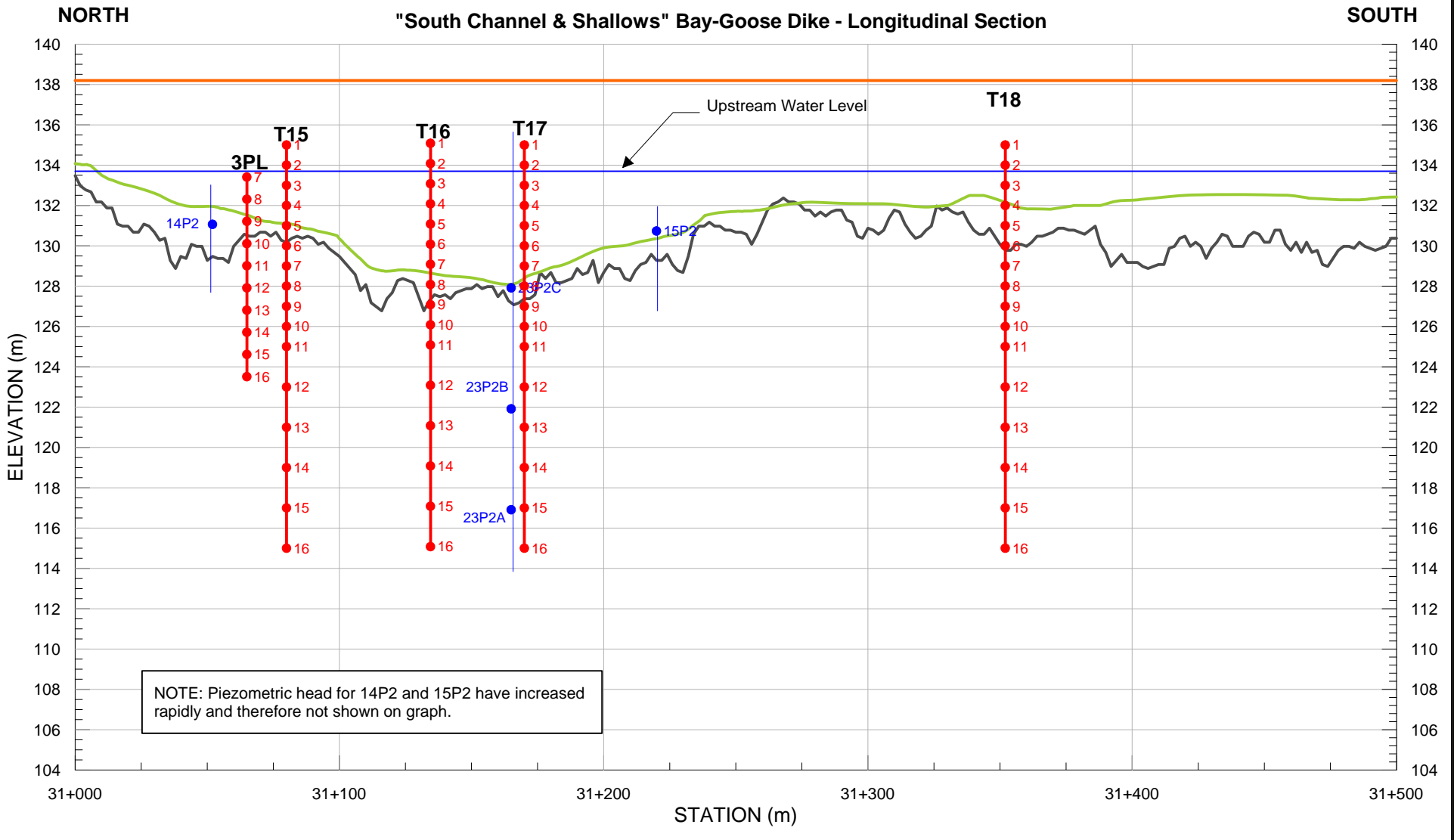

LEGEND

Dike Crest	T min
Piezometric Head in Downstream Piezometers	T current
Lake Bed	T max
Bedrock	
Lake	Vibrating Wire Piezometer Installation Level
Till	SB
Bedrock	CSB
Thermistor with Bead Locations	Jet Grouting
	Grouting

NOTES:
1. Thermistor 3PL is installed upstream of the dike within Third Portage Lake.

PROJECT				AGNICO EAGLE MINES LIMITED MEADOWBANK GOLD PROJECT NUNAVUT			
TITLE				BAYGOOSE DIKE 31+000 to 31+500 - TEMPERATURE DATA (Aug 31/15 to Aug 31/16)			
PROJECT No.		PHASE No.		DESIGN		SCALE AS SHOWN	
DESIGN	TD	20JAN14	SCALE	AS SHOWN	REV.		
CADD	TD	20JAN14	FIGURE 27				
CHECK							
REVIEW							



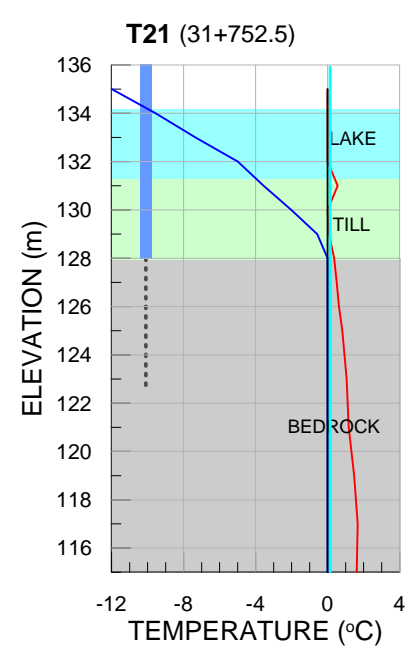
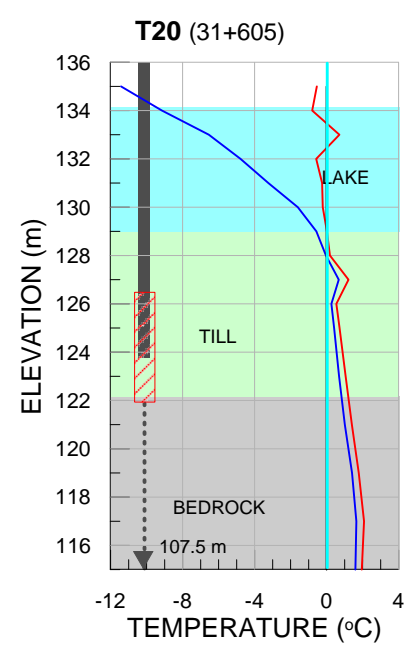
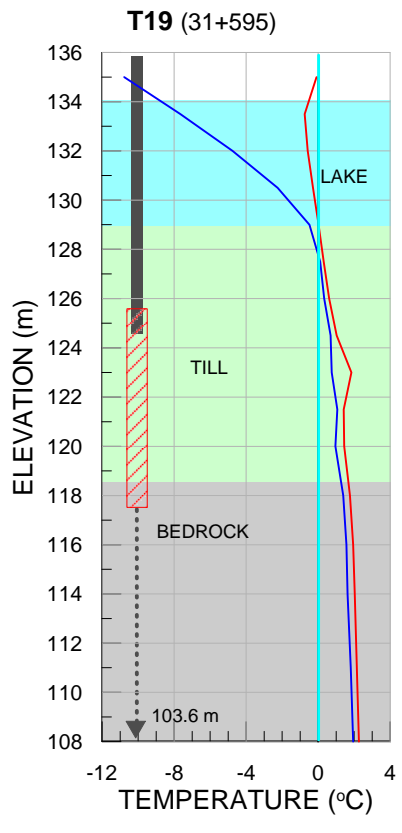
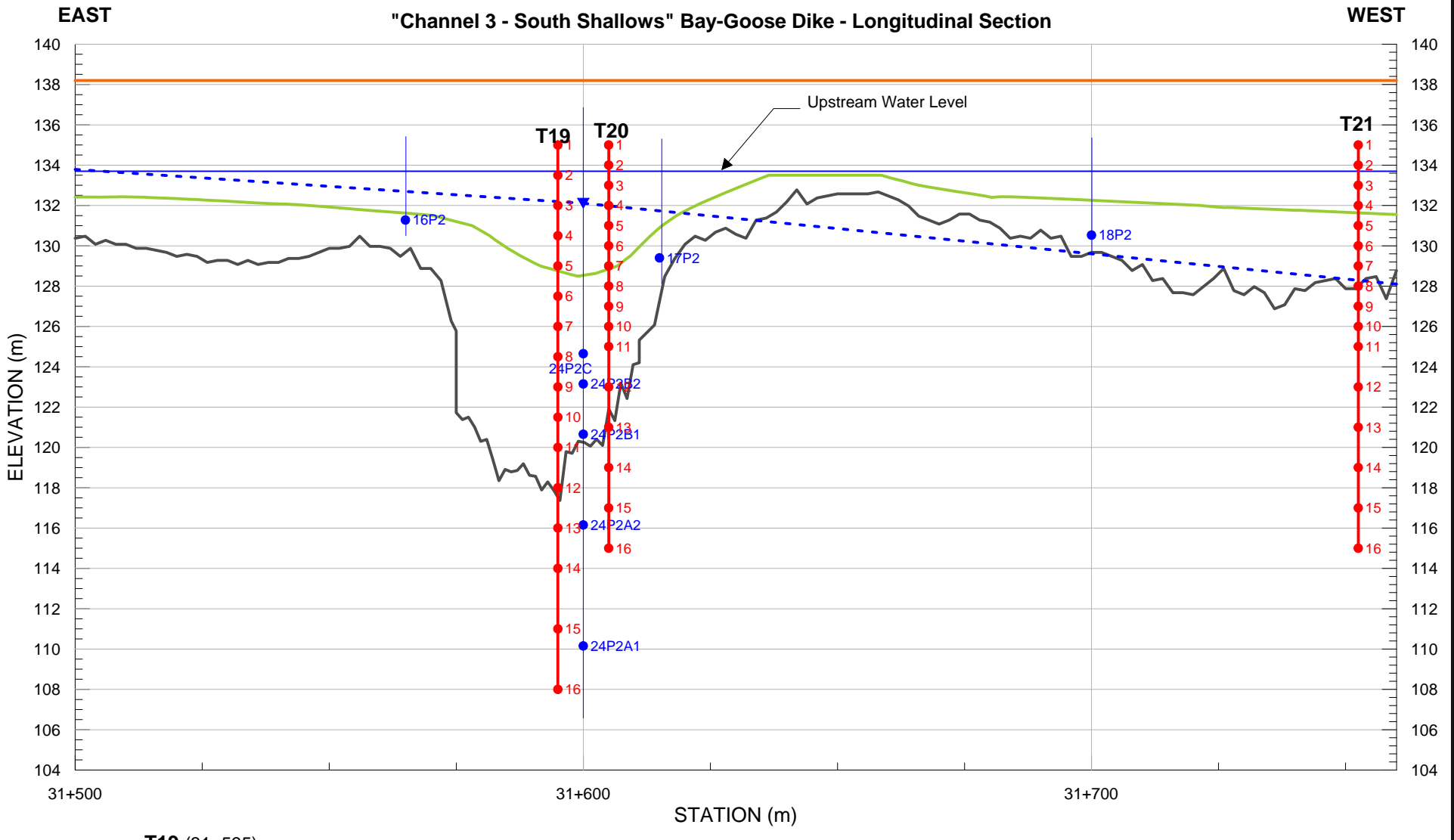

LEGEND

- Dike Crest
- - - Piezometric Head in Downstream Piezometers
- Lake Bed
- Bedrock
- █ Lake
- █ Till
- █ Bedrock
- 6, 7, 8, 9 Thermistor with Bead Locations
- T min
- T current
- T max
- Vibrating Wire Piezometer Installation Level
- █ SB
- █ CSB
- █ Jet Grouting
- ⋮ Grouting

PROJECT		AGNICOEAGLE MINES LIMITED MEADOWBANK GOLD PROJECT NUNAVUT		
TITLE		BAYGOOSE DIKE 31+500 to 31+760 - TEMPERATURE DATA (Aug 31/15 to Aug 31/16)		
	PROJECT No.	PHASE No.		
	DESIGN TD 20JAN14	SCALE	AS SHOWN	REV.
	CADD TD 20JAN14	FIGURE 28		
	CHECK			
REVIEW				

SOUTHEAST

"Channel 2 & Channel 1" Bay-Goose Dike - Longitudinal Section

NORTHWEST

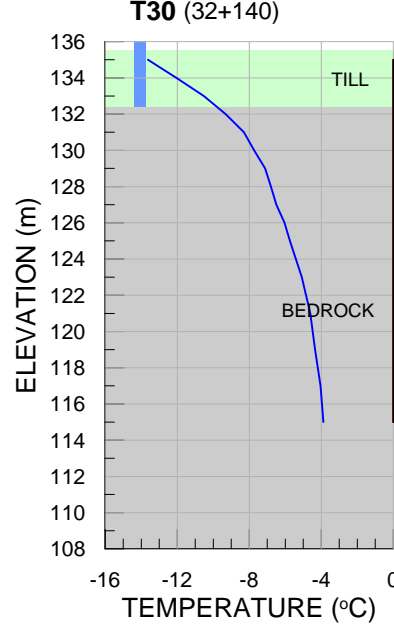
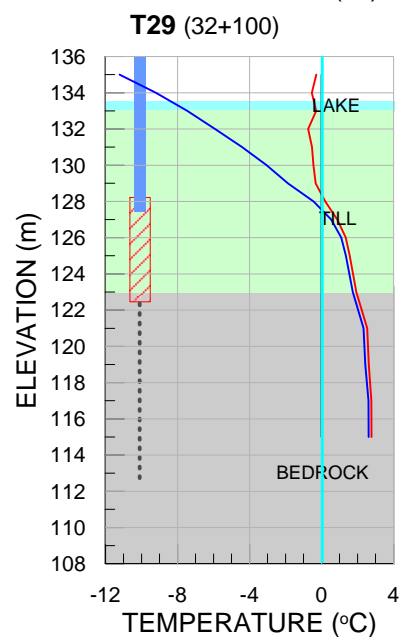
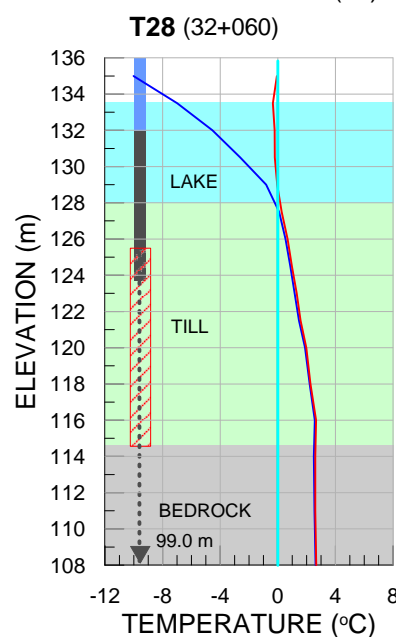
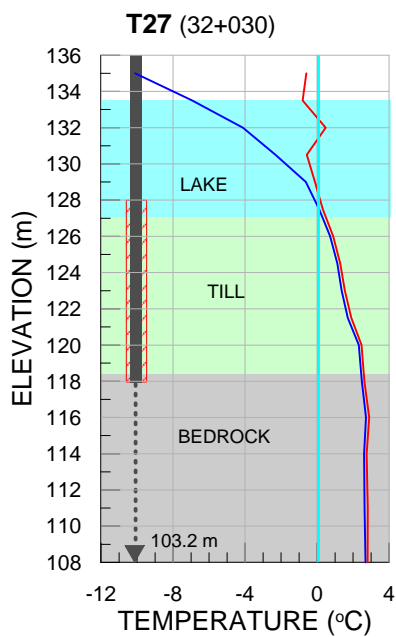
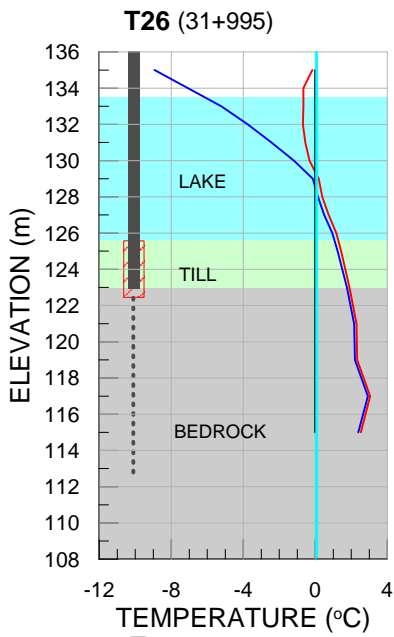
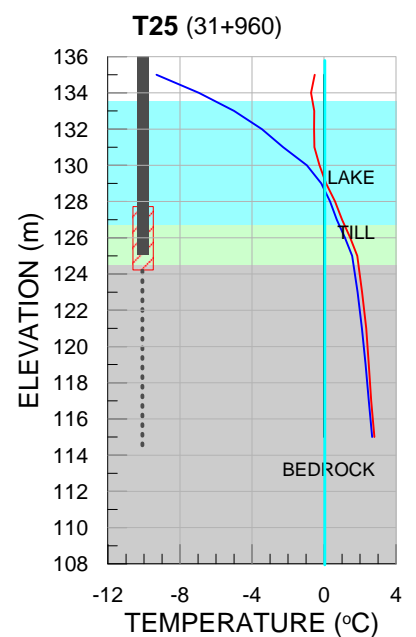
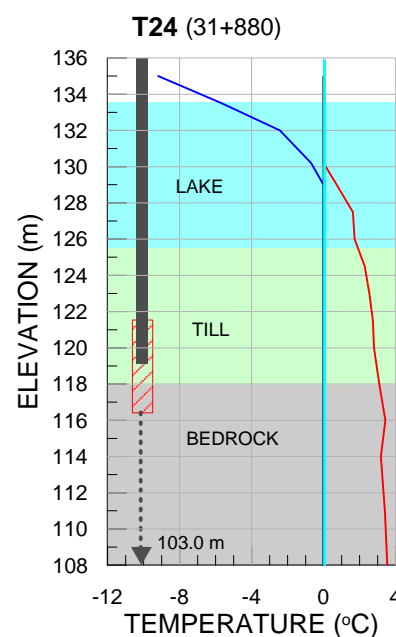
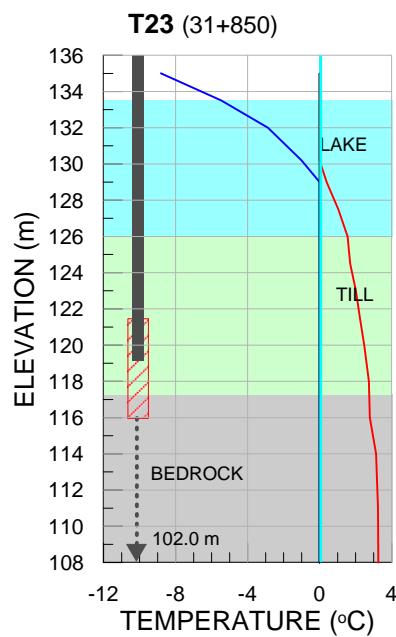
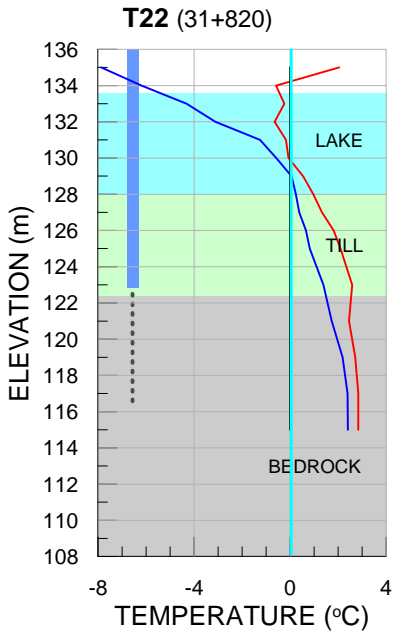
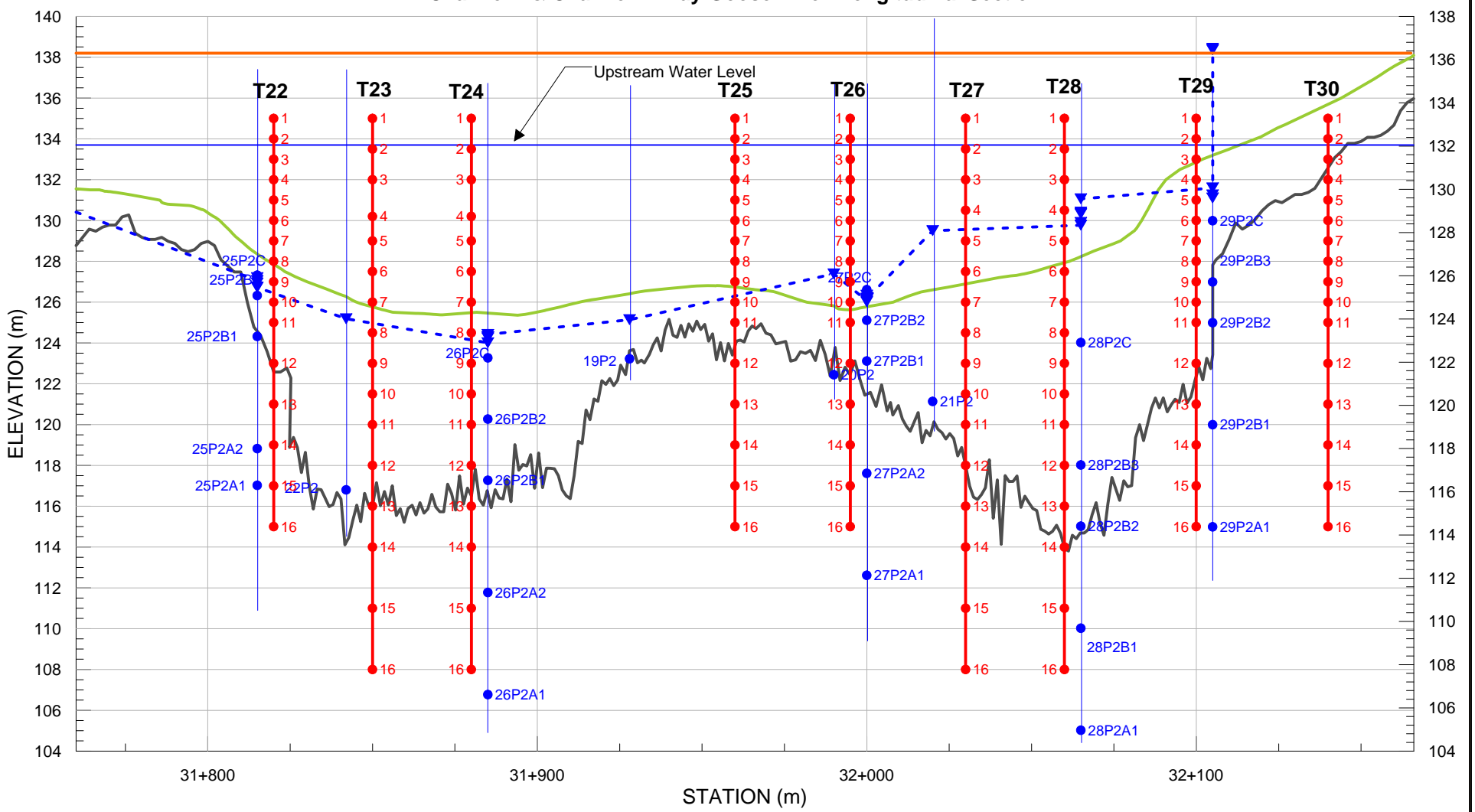

LEGEND

- T min
- T current
- T max
- - - Piezometric Head in Downstream Piezometers
- Lake Bed
- Bedrock
- Lake
- Till
- Bedrock
- Vibrating Wire Piezometer Installation Level
- | SB
- | CSB
- Jet Grouting
- Grouting
- 6, 7, 8, 9 Thermistor with Bead Locations

PROJECT		AGNICO EAGLE MINES LIMITED MEADOWBANK GOLD PROJECT NUNAVUT		
TITLE		BAYGOOSE DIKE 31+760 to 32+166 - TEMPERATURE DATA (Aug 31/15 to Aug 31/16)		
PROJECT No.		PHASE No.		
DESIGN	TD	20JAN14	SCALE	AS SHOWN
CADD	TD	20JAN14	REV.	
CHECK			FIGURE 29	
REVIEW				

T1 (30+134) NODES 1 TO 8

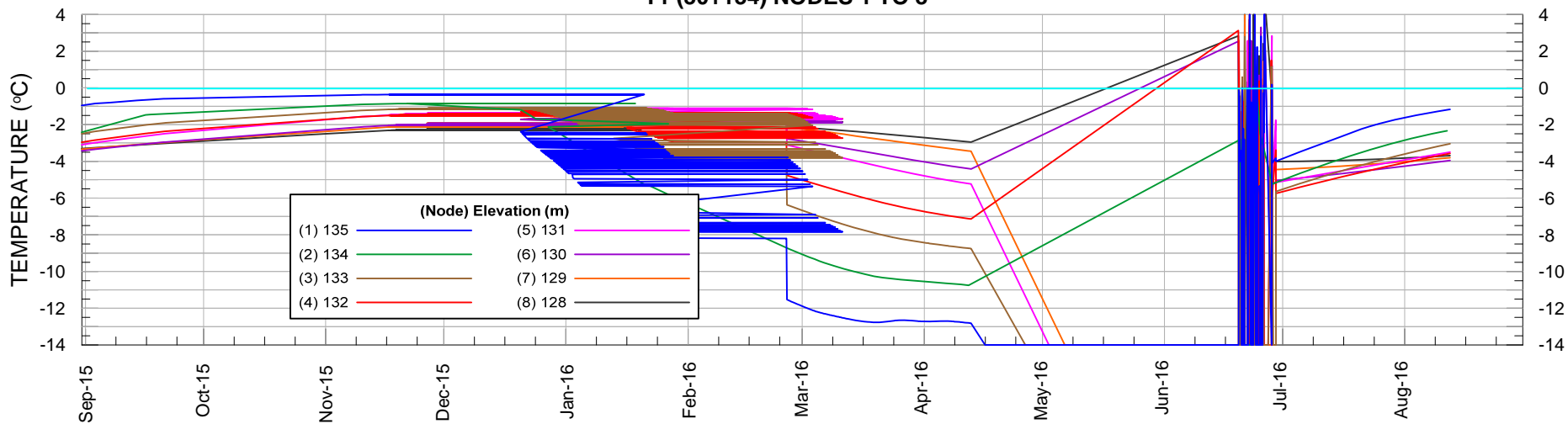

T1 (30+134) NODES 9 TO 16

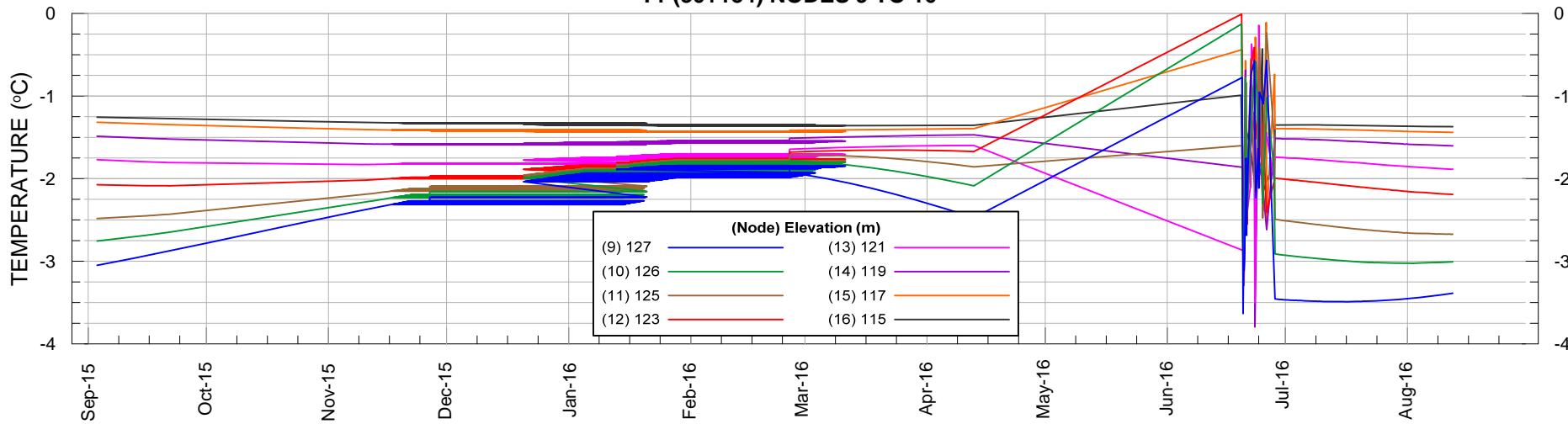

T2 (30+185) NODES 1 TO 8

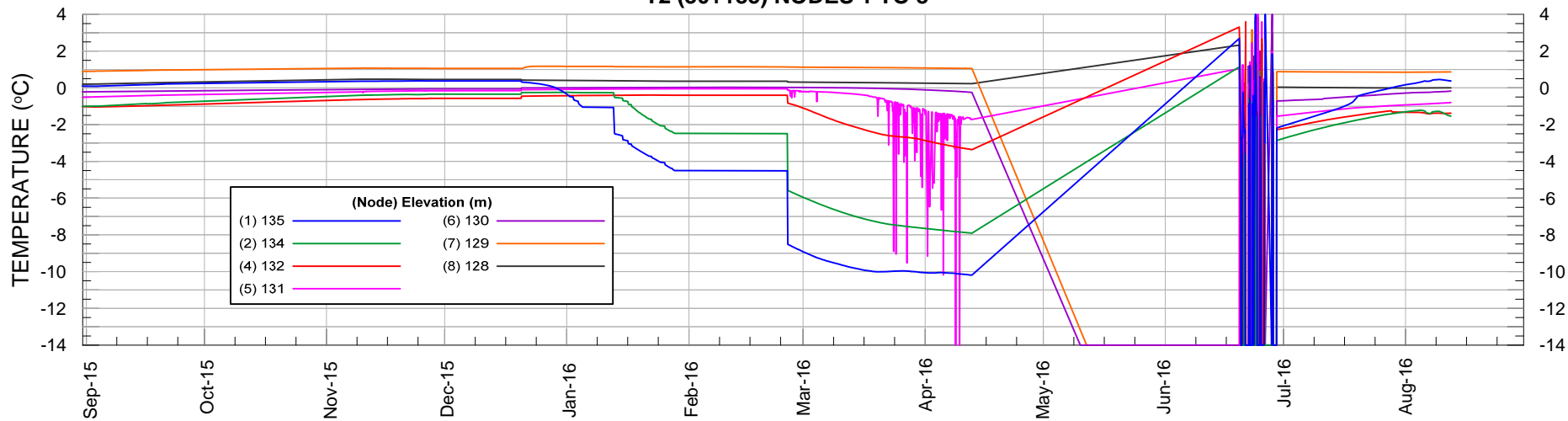

T2 (30+185) NODES 9 TO 16

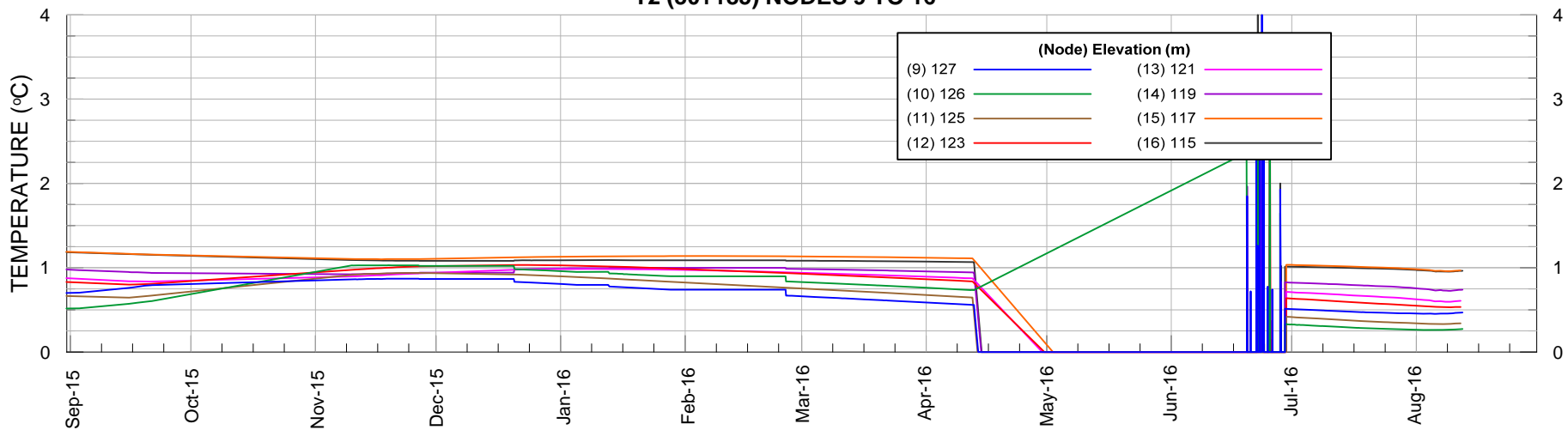

NOTES:

1. T1 (30+134) - values less than -0.5°C are not shown for Node 8 at elevation 128 m from June 24, 2011 to June 30, 2011 as these values are believed to be inaccurate.
2. Third node of thermistor T2 (elevation 135 m) is not functional.
3. T1 and T2 thermistors stopped transmitting data on June 10, 2015. Inspecting areas to determine a cause.

PROJECT		AGNICO EAGLE MINES LIMITED MEADOWBANK GOLD PROJECT NUNAVUT			
TITLE		BAYGOOSE DIKE NODAL THERMAL TIMELINES (Aug 31/15 to Aug 31/16)			
	PROJECT No.	PHASE No.		FIGURE 30	
	DESIGN TD	20JAN14	SCALE AS SHOWN		REV.
	CADD TD	20JAN14			
	CHECK				
REVIEW					

T3 (30+260) NODES 1 TO 8

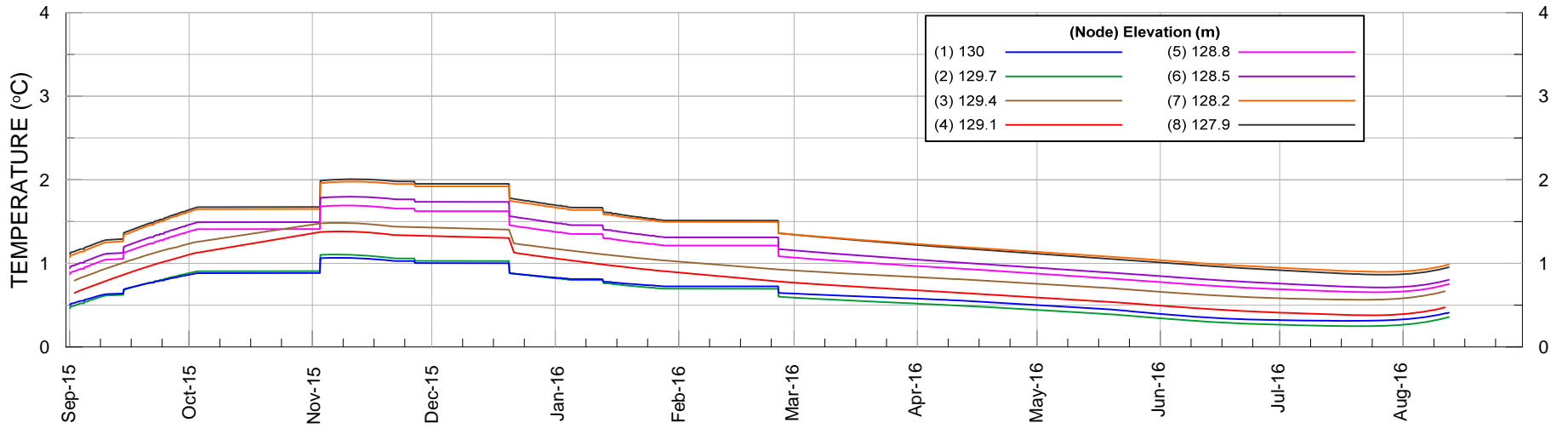

T3 (30+260) NODES 9 TO 16

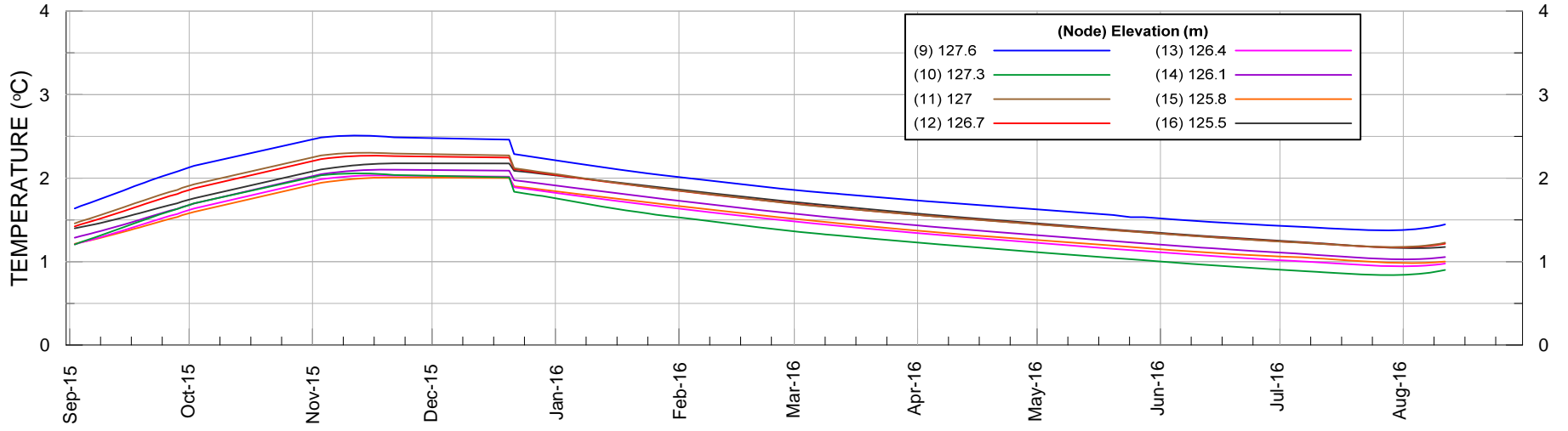

T4 (30+272) NODES 1 TO 8

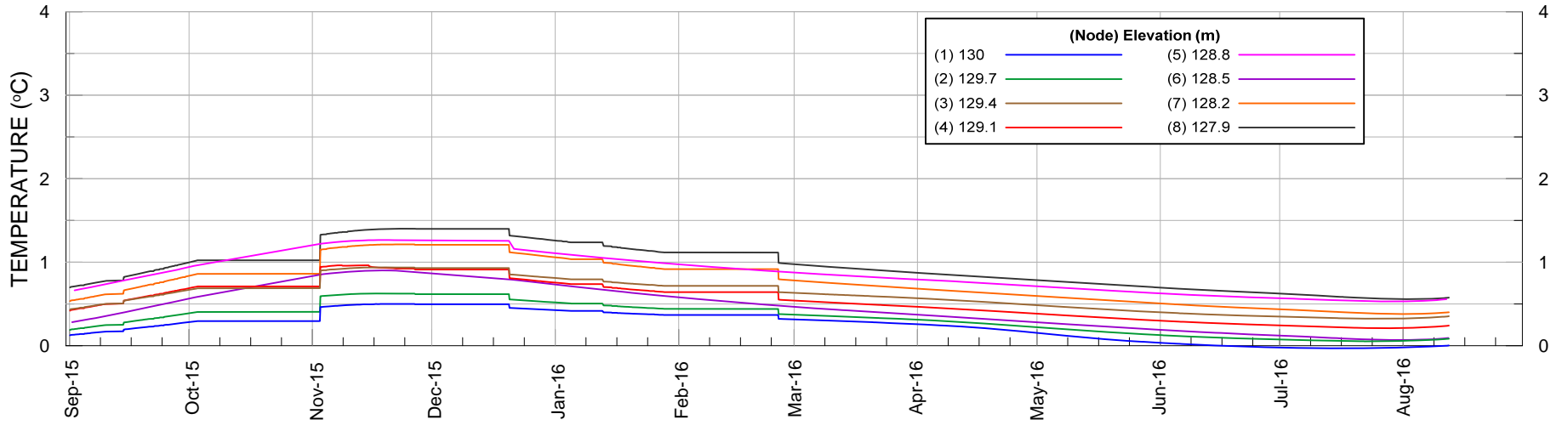

T4 (30+272) NODES 9 TO 16

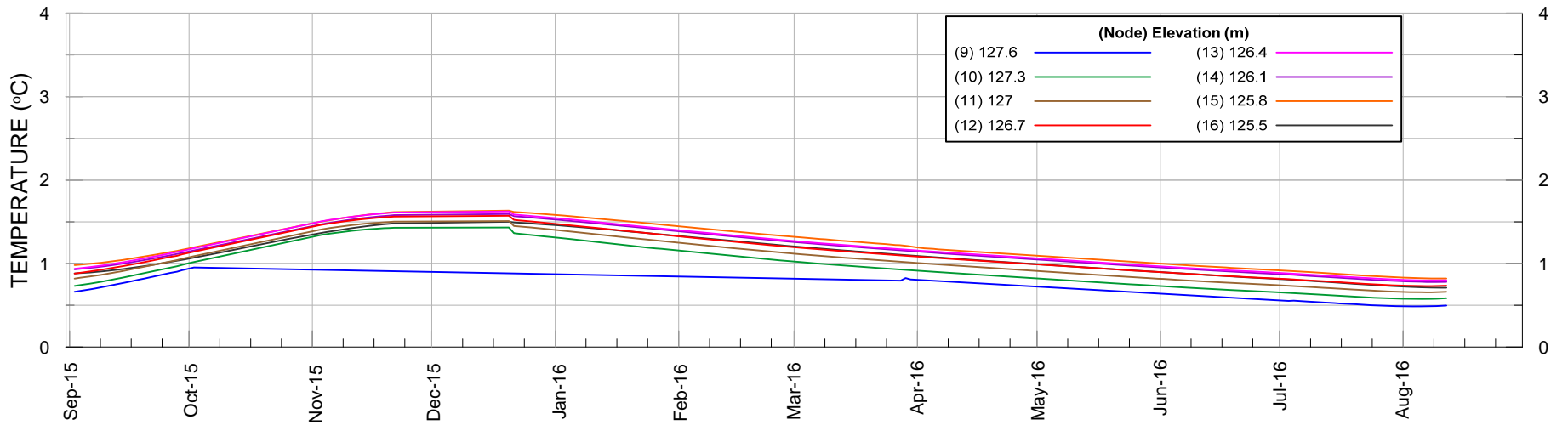

PROJECT		AGNICO EAGLE MINES LIMITED MEADOWBANK GOLD PROJECT NUNAVUT		
TITLE		BAYGOOSE DIKE NODAL THERMAL TIMELINES (Aug 31/15 to Aug 31/16)		
	PROJECT No.		PHASE No.	
	DESIGN	TD	20JAN14	SCALE AS SHOWN
	CADD	TD	20JAN14	REV.
	CHECK			
	REVIEW			FIGURE 31

T5 (30+288.5) NODES 1 TO 8

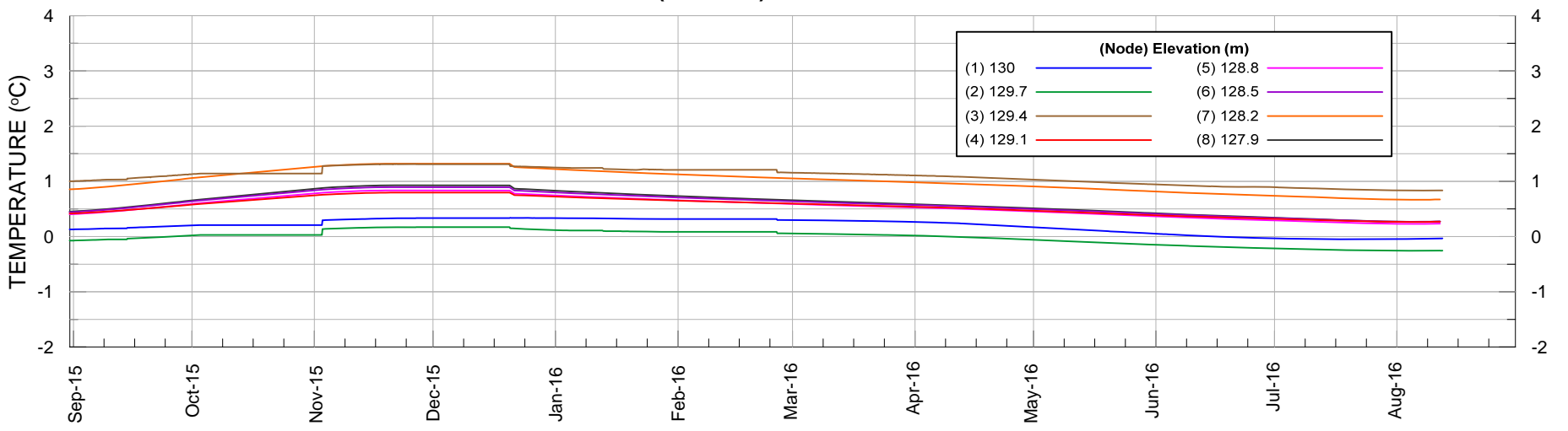

T5 (30+288.5) NODES 9 TO 16

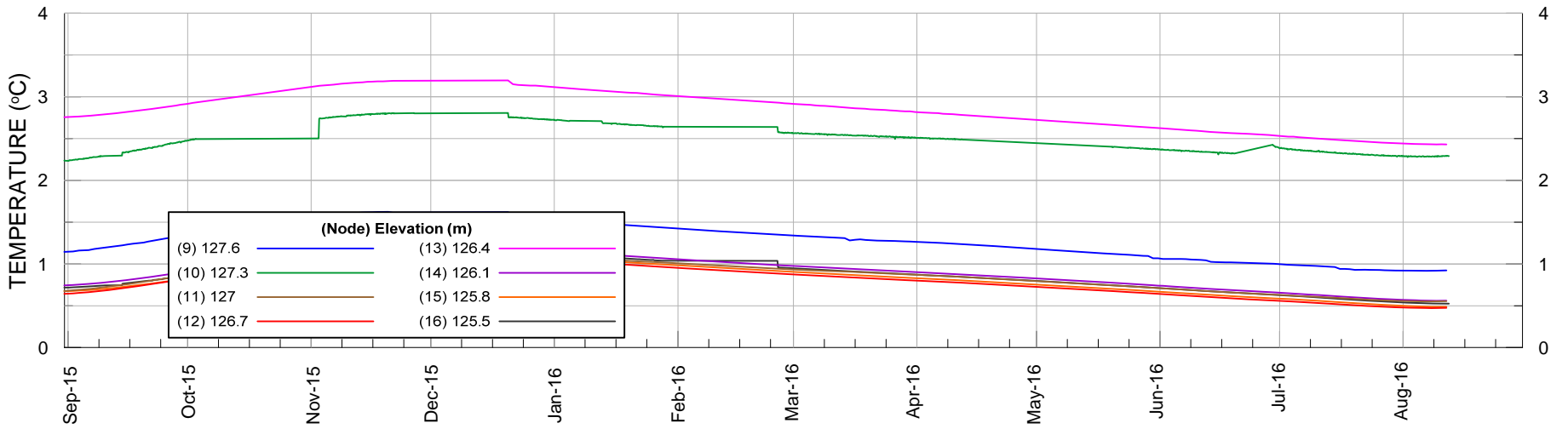

T6 (30+330.5) NODES 1 TO 8

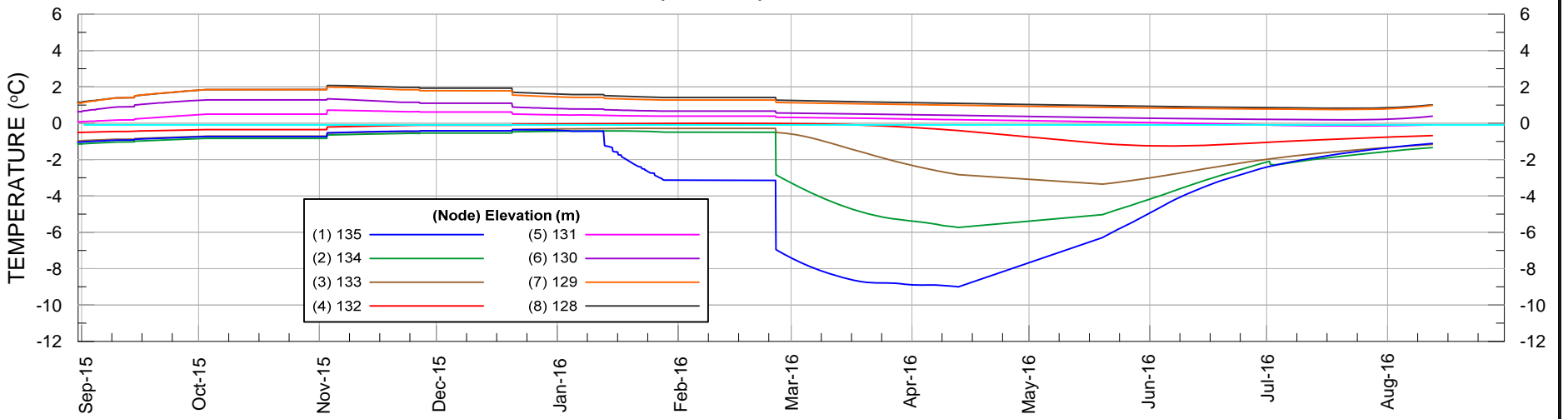

T6 (30+330.5) NODES 9 TO 16

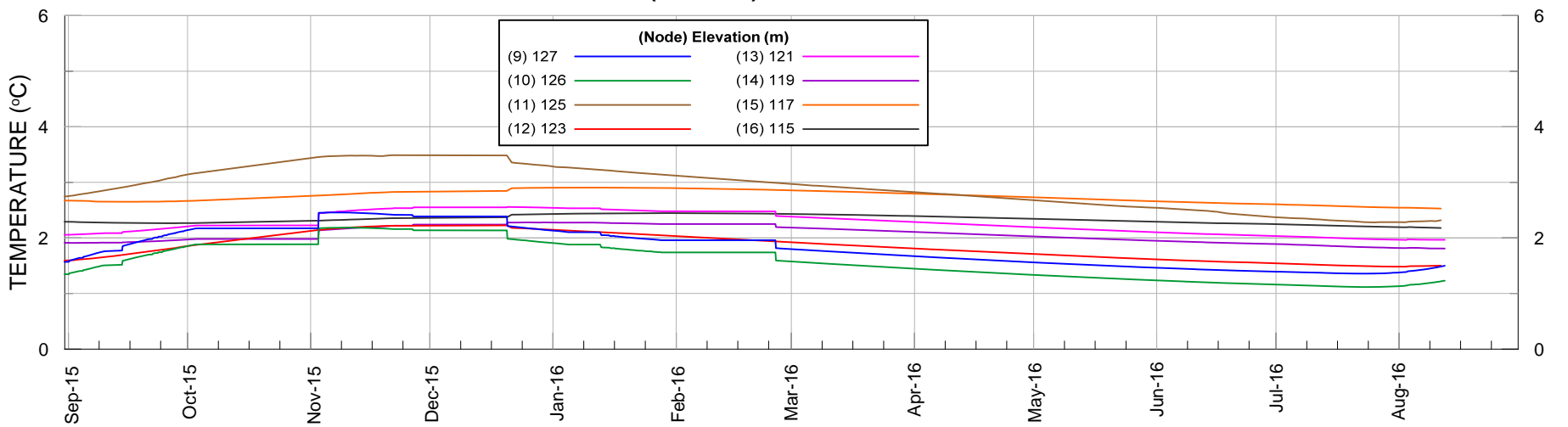

NOTE:

PROJECT		AGNICO EAGLE MINES LIMITED MEADOWBANK GOLD PROJECT NUNAVUT		
TITLE		BAYGOOSE DIKE NODAL THERMAL TIMELINES (Aug 31/15 to Aug 31/16)		
	PROJECT No.		PHASE No.	
	DESIGN	TD	20JAN14	SCALE AS SHOWN
	CADD	TD	20JAN14	REV.
	CHECK			
REVIEW				FIGURE 32

T7 (30+386) NODES 1 TO 8

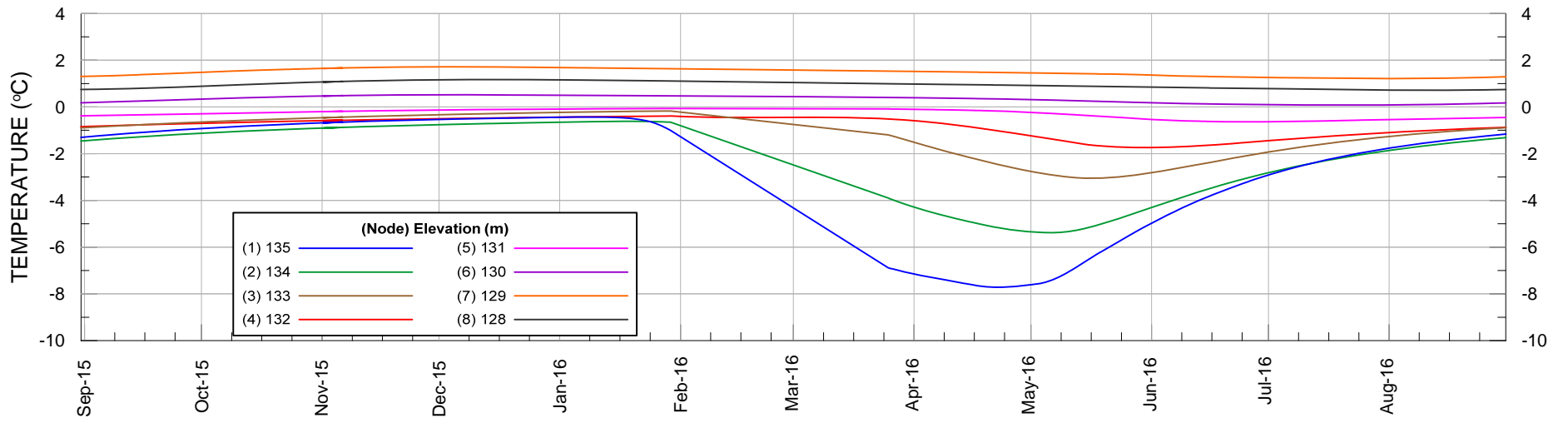

T7 (30+386) NODES 9 TO 16

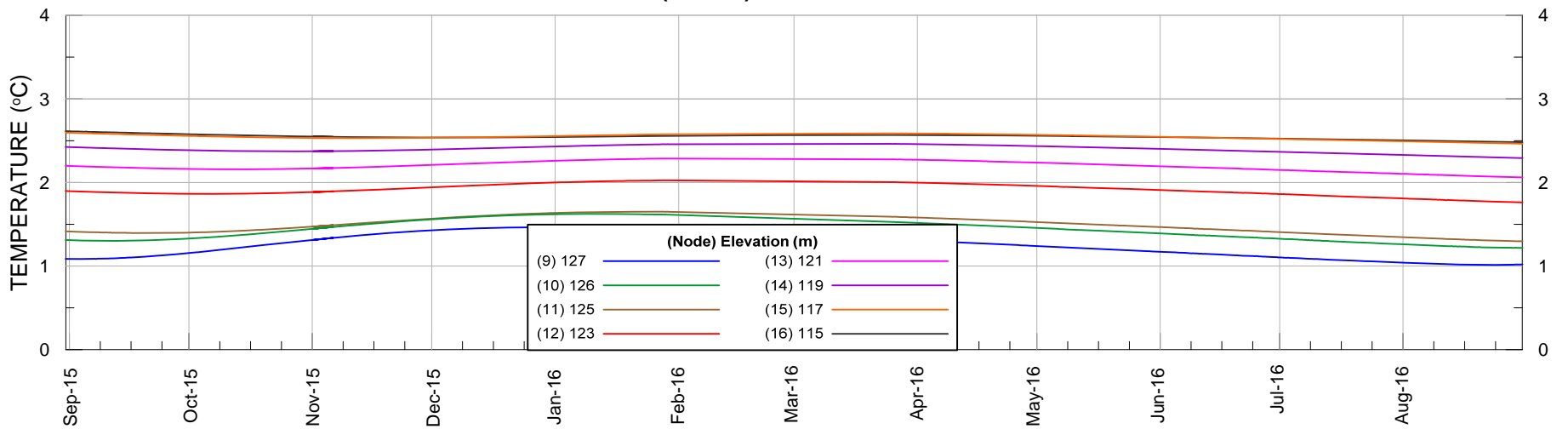

T8 (30+417.5) NODES 1 TO 8

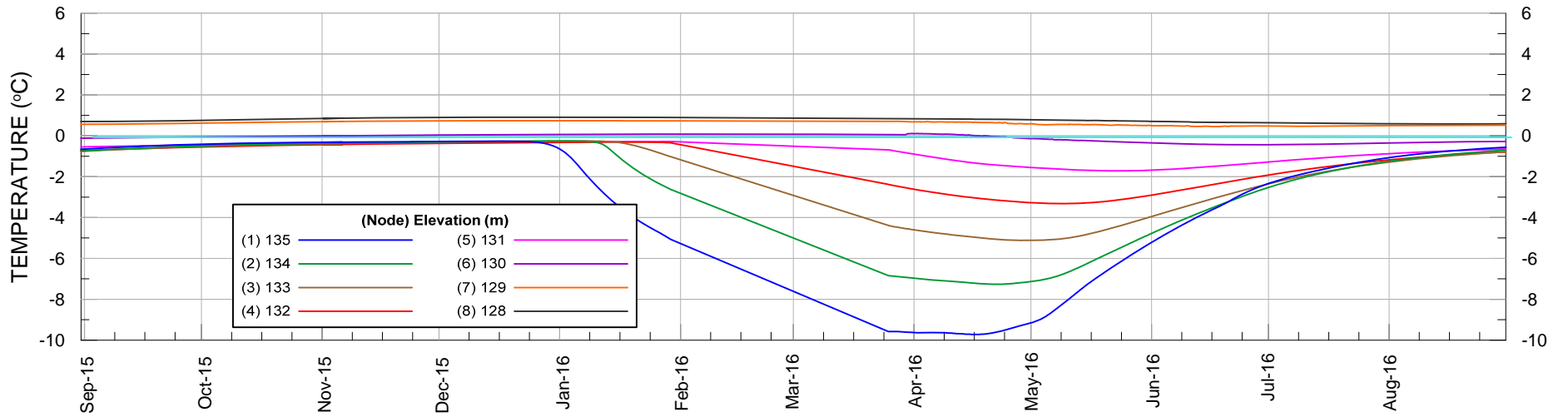

T8 (30+417.5) NODES 9 TO 16

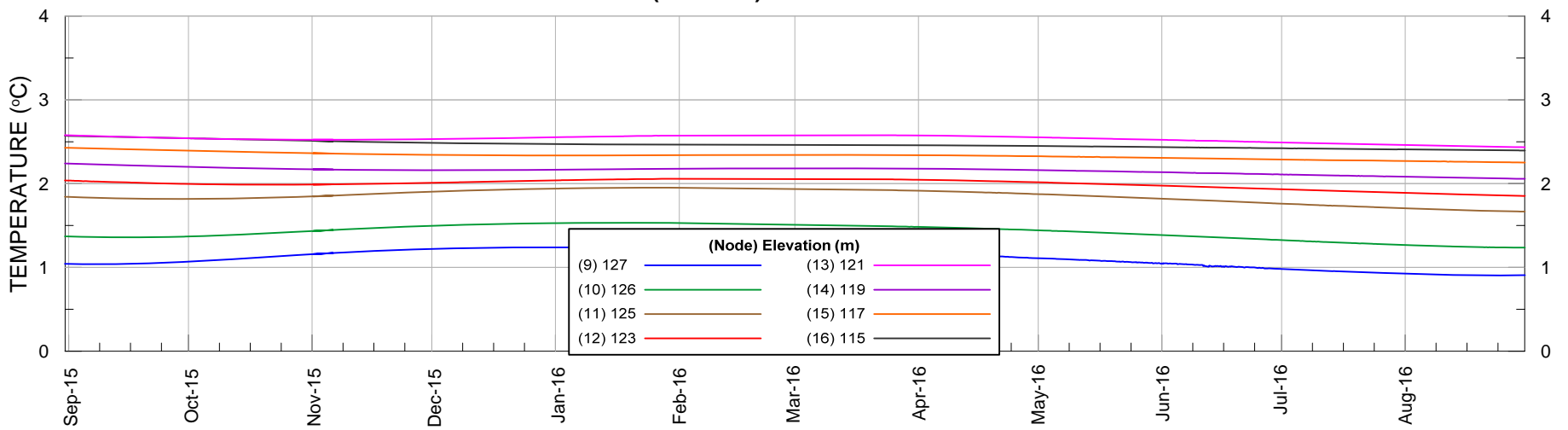

NOTE:

PROJECT		AGNICO EAGLE MINES LIMITED MEADOWBANK GOLD PROJECT NUNAVUT		
TITLE		BAYGOOSE DIKE NODAL THERMAL TIMELINES (Aug 31/15 to Aug 31/16)		
	PROJECT No.		PHASE No.	
	DESIGN	TD	20JAN14	SCALE AS SHOWN
	CADD	TD	20JAN14	REV.
	CHECK			
REVIEW				
				FIGURE 33

T9 (30+489.5) NODES 1 TO 8

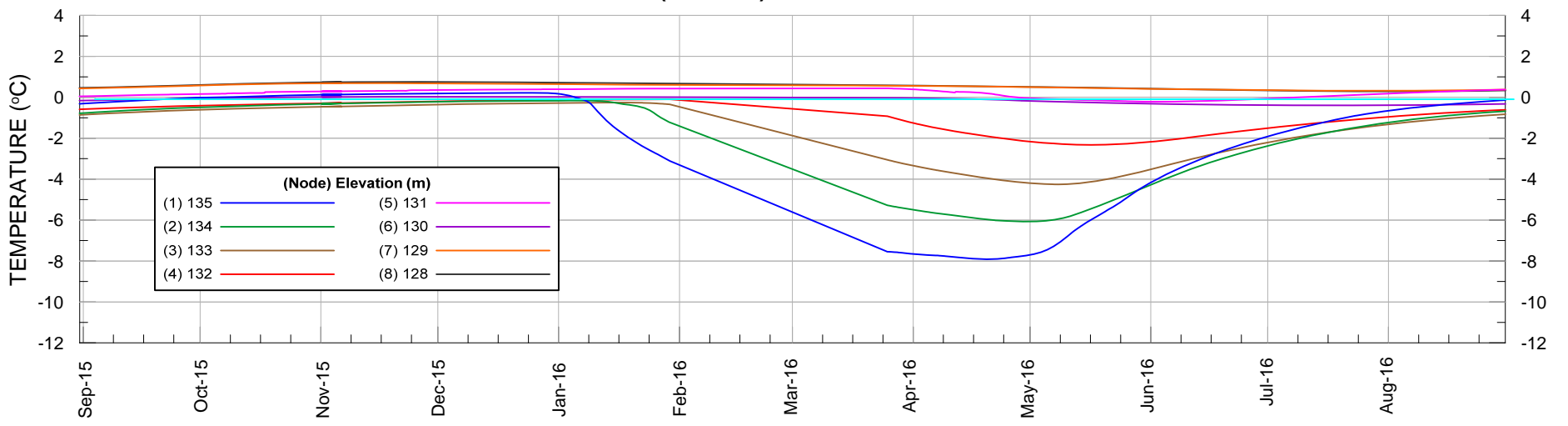

T9 (30+489.5) NODES 9 TO 16

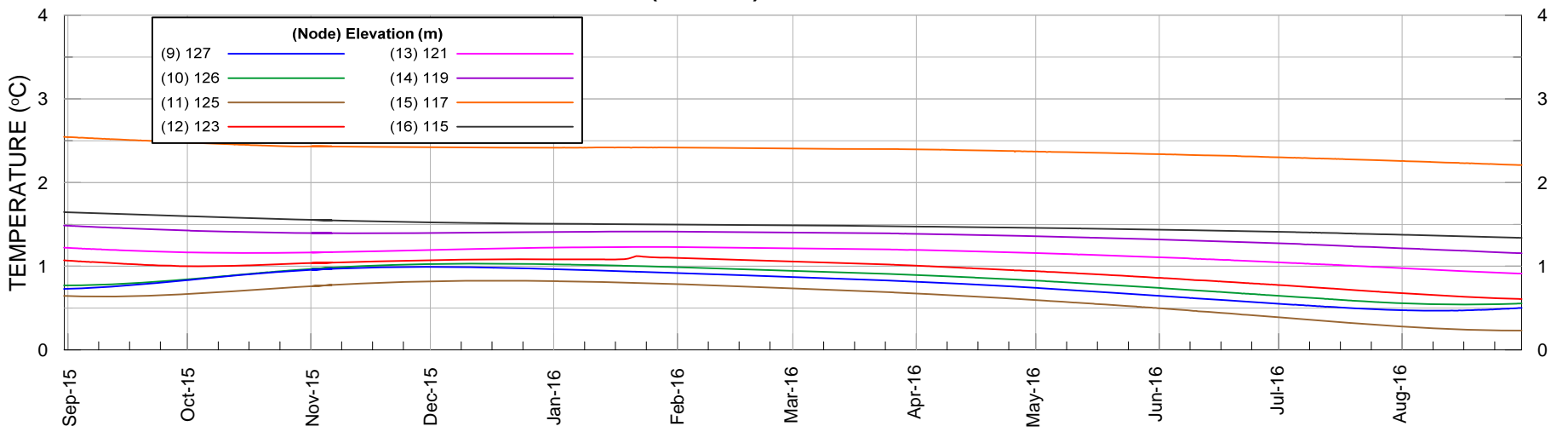

T10 (30+553.25) NODES 1 TO 8

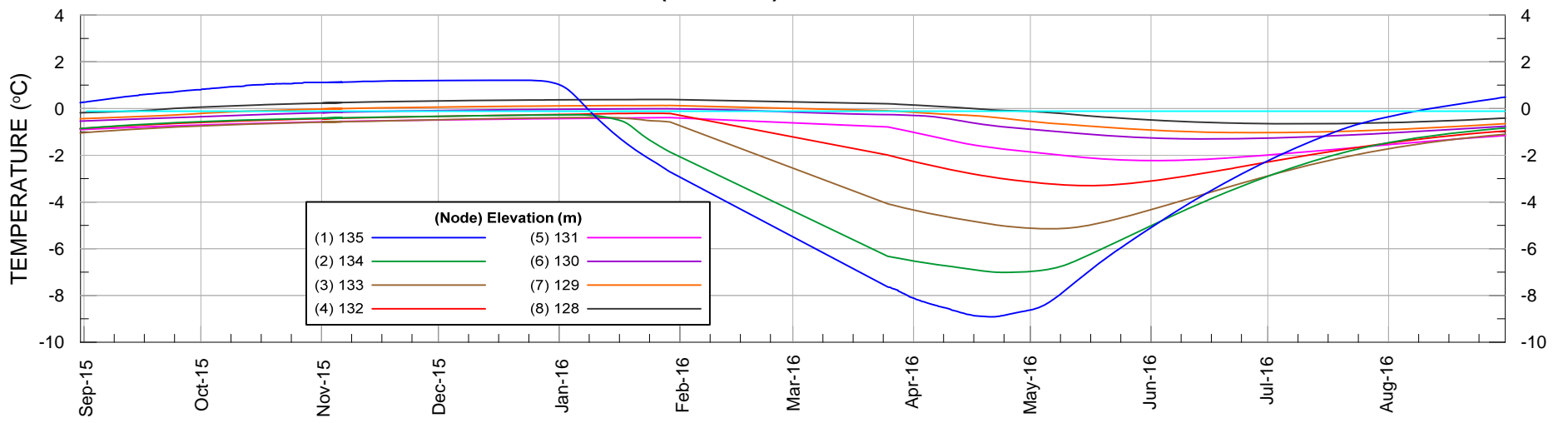

T10 (30+553.25) NODES 9 TO 16

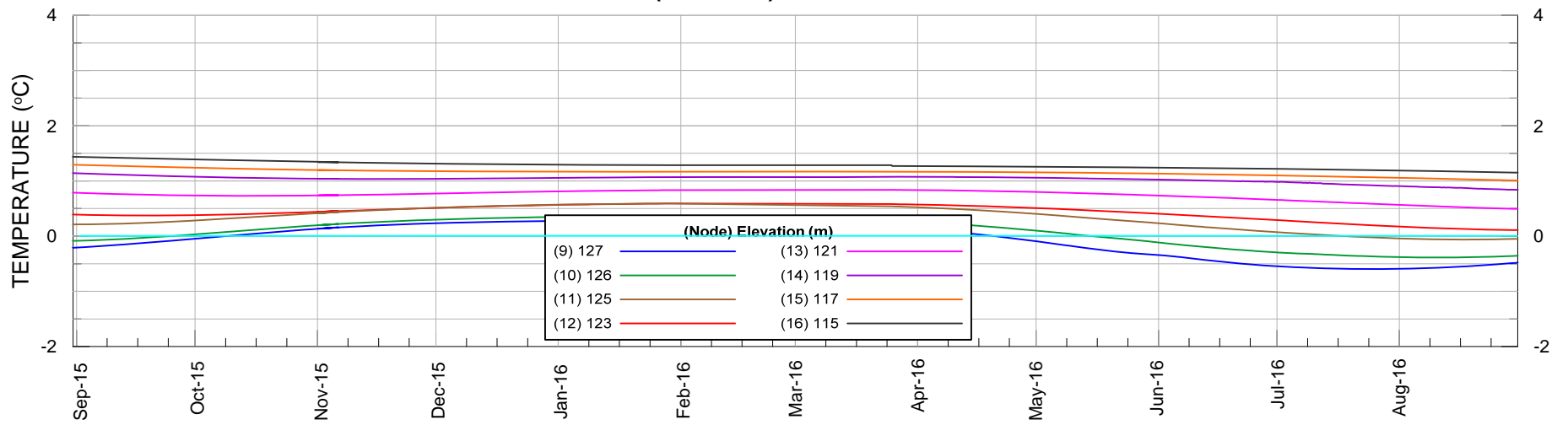

PROJECT	AGNICO EAGLE MINES LIMITED MEADOWBANK GOLD PROJECT NUNAVUT				
TITLE	BAYGOOSE DIKE NODAL THERMAL TIMELINES (Aug 31/15 to Aug 31/16)				
	PROJECT No.		PHASE No.		
	DESIGN	TD	20JAN14	SCALE	AS SHOWN
	CADD	TD	20JAN14	REV.	
	CHECK			FIGURE 34	
REVIEW					

T11 (30+621.5) NODES 1 TO 8

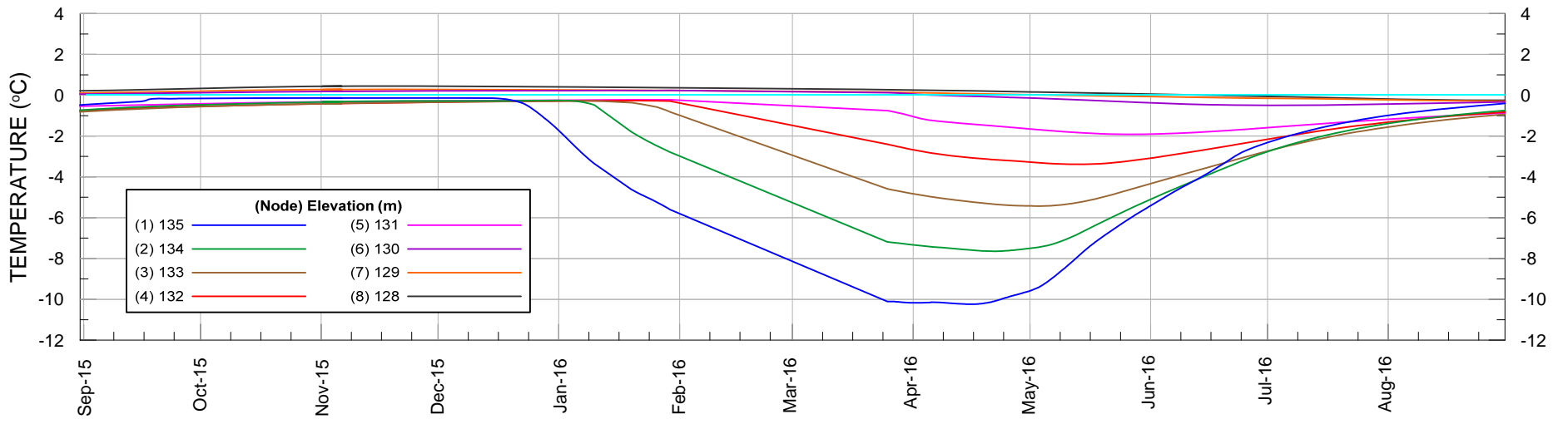

T11 (30+621.5) NODES 9 TO 16

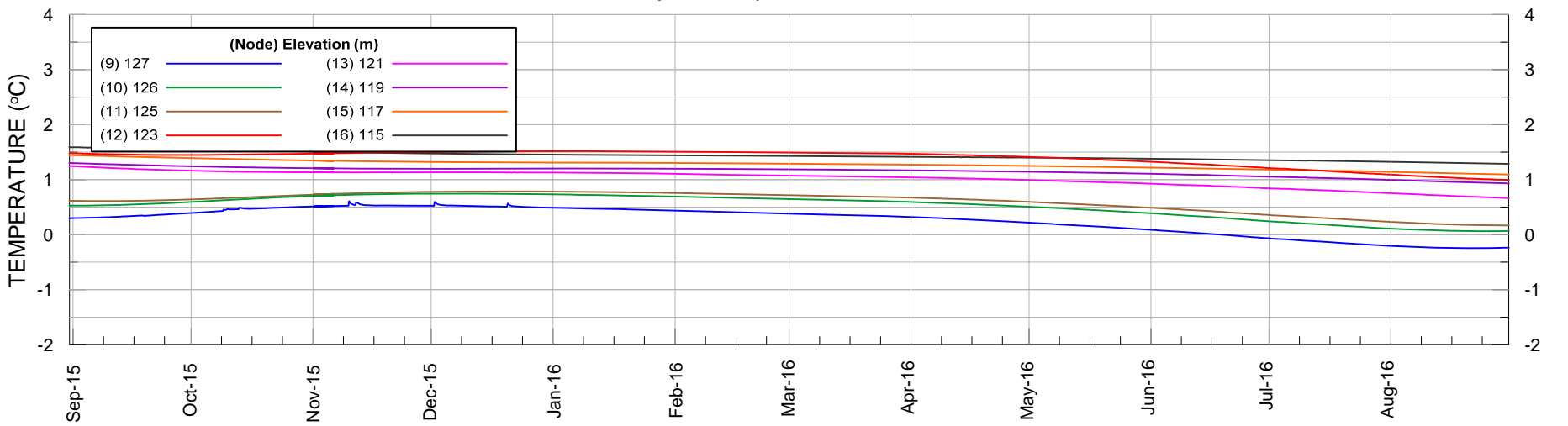

T12 (30+650) NODES 1 TO 8

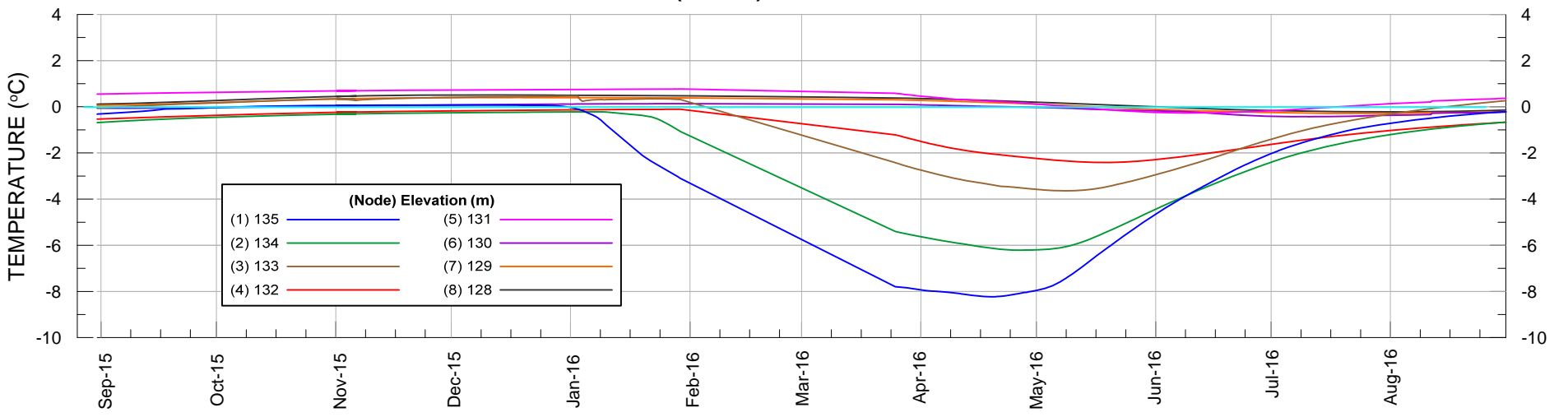

T12 (30+650) NODES 9 TO 16

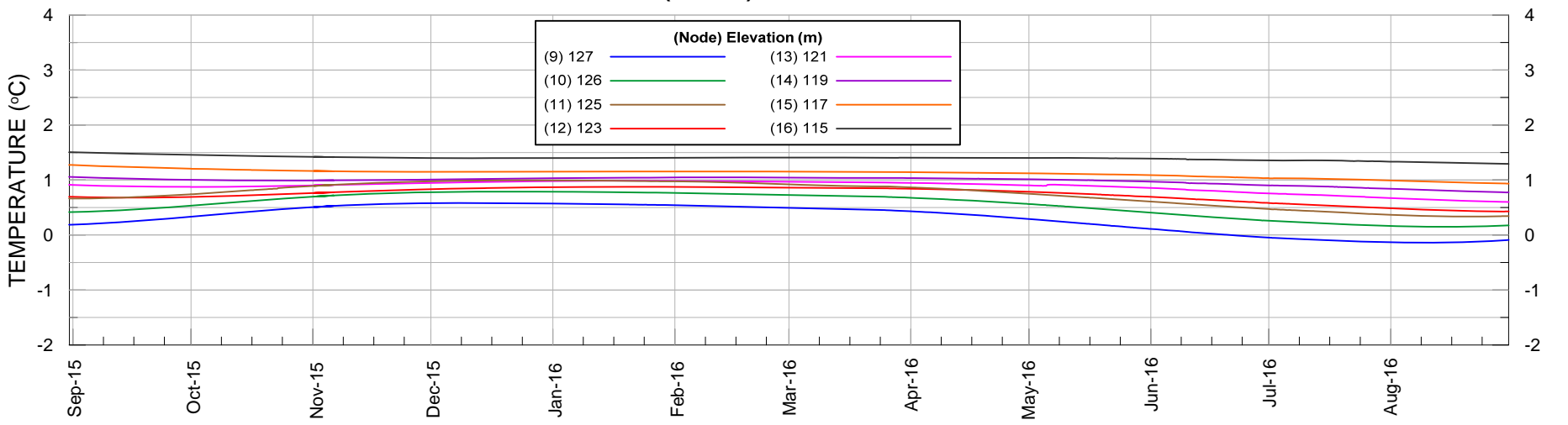

PROJECT		AGNICO EAGLE MINES LIMITED MEADOWBANK GOLD PROJECT NUNAVUT		
TITLE		BAYGOOSE DIKE NODAL THERMAL TIMELINES (Aug 31/15 to Aug 31/16)		
	PROJECT No.	PHASE No.		
	DESIGN TD 20JAN14	SCALE	AS SHOWN	
	CADD TD 20JAN14	REV.		
	CHECK	FIGURE 35		
REVIEW				

T13 (30+713) NODES 1 TO 8

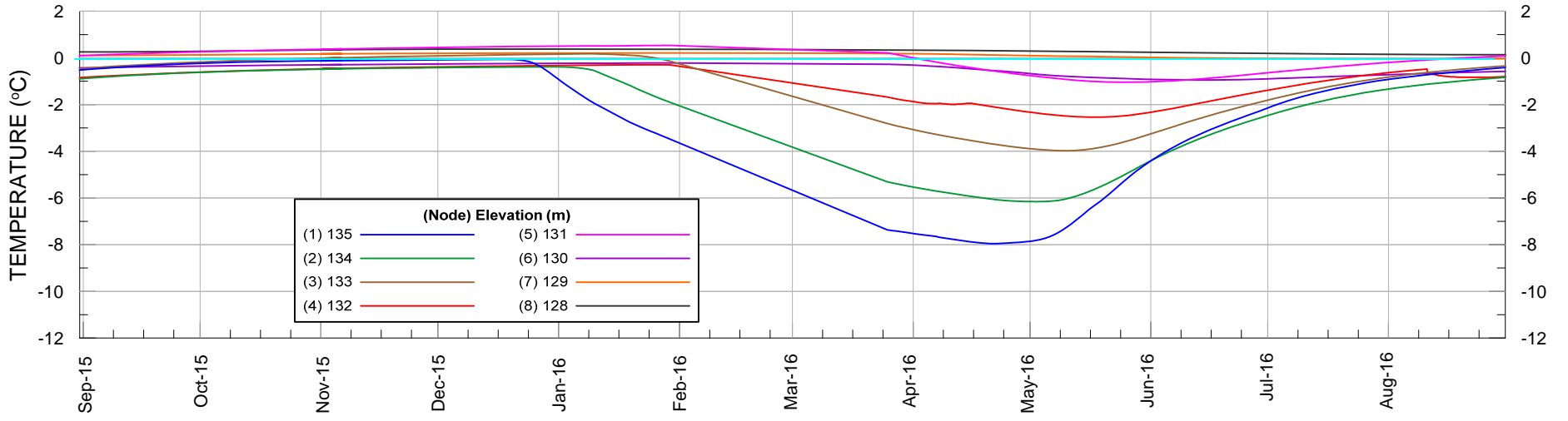

T13 (30+713) NODES 9 TO 16

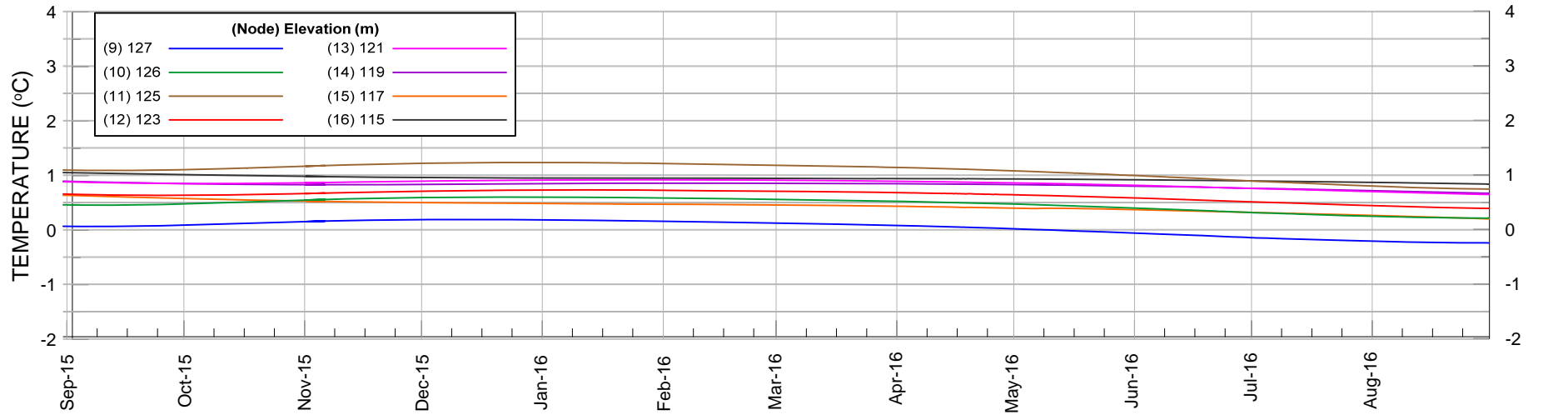

T14 (30+827) NODES 1 TO 8

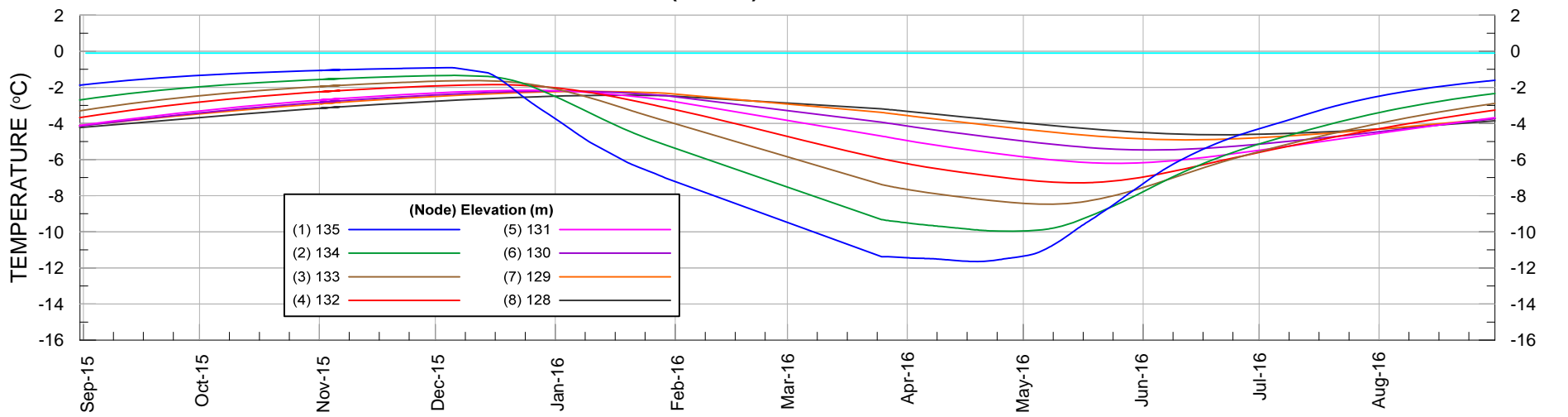

T14 (30+827) NODES 9 TO 16

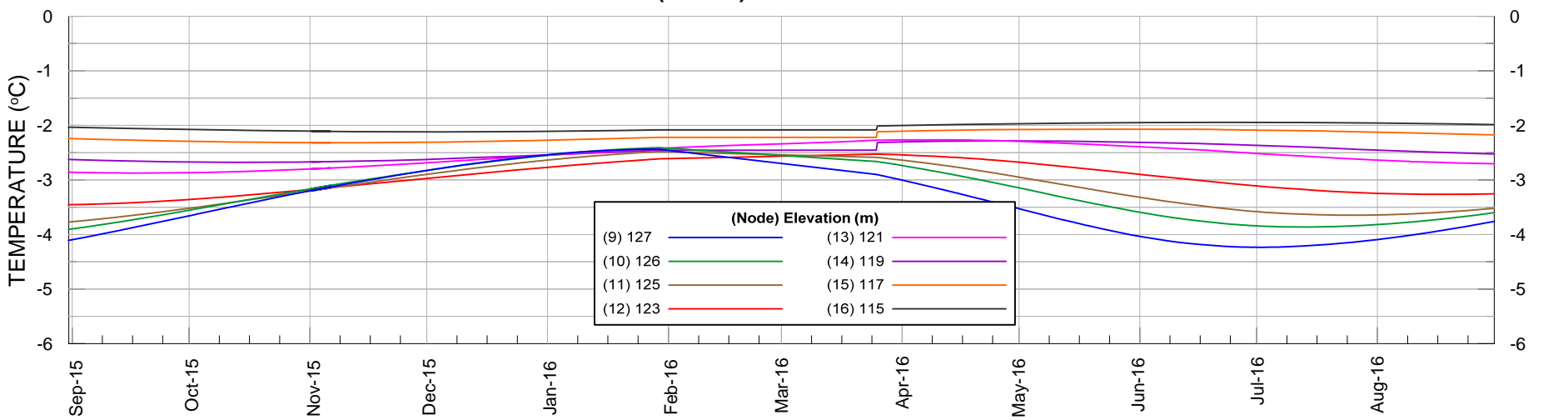

PROJECT		AGNICO EAGLE MINES LIMITED MEADOWBANK GOLD PROJECT NUNAVUT		
TITLE		BAYGOOSE DIKE NODAL THERMAL TIMELINES (Aug 31/15 to Aug 31/16)		
	PROJECT No.	PHASE No.		
	DESIGN TD	20JAN14	SCALE AS SHOWN	REV.
	CADD TD	20JAN14		
	CHECK			
REVIEW				
		FIGURE 36		

T15 (31+080) NODES 1 TO 8

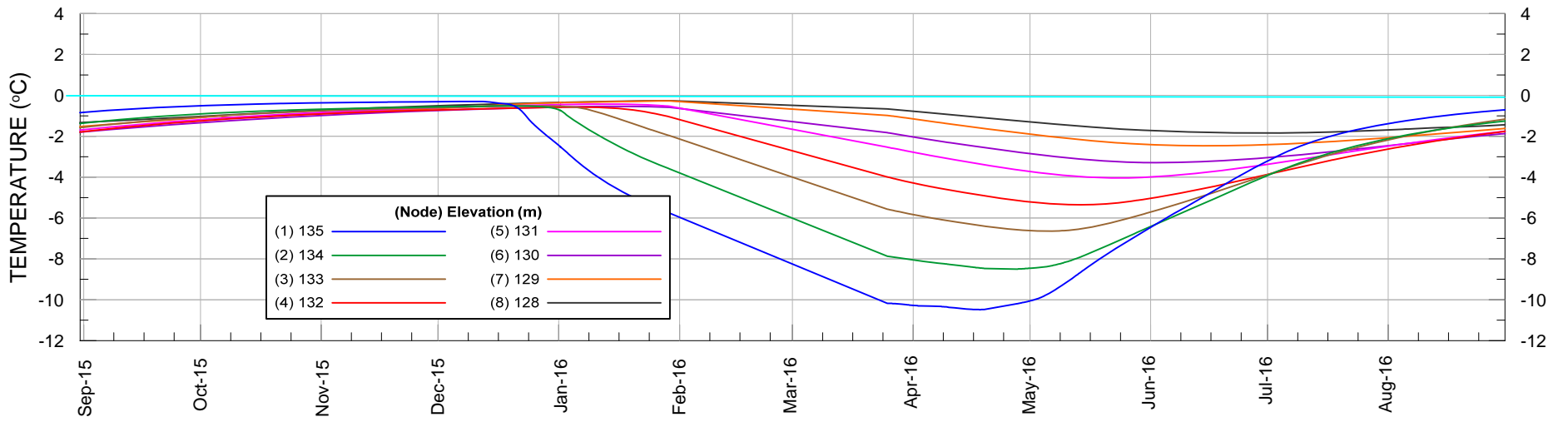

T15 (31+080) NODES 9 TO 16

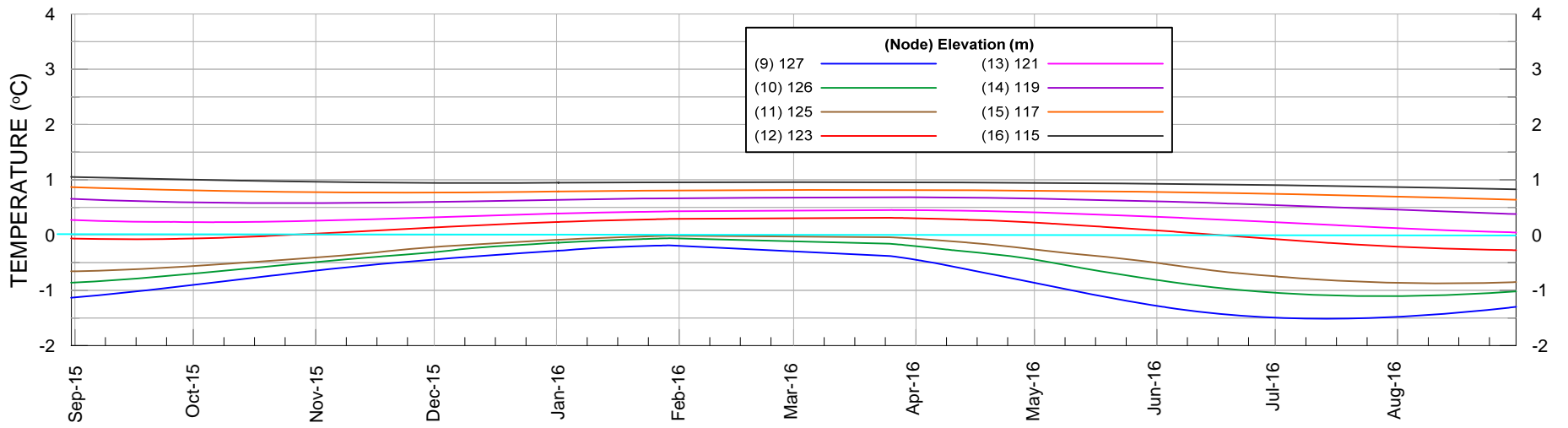

T16 (31+134.5) NODES 1 TO 8

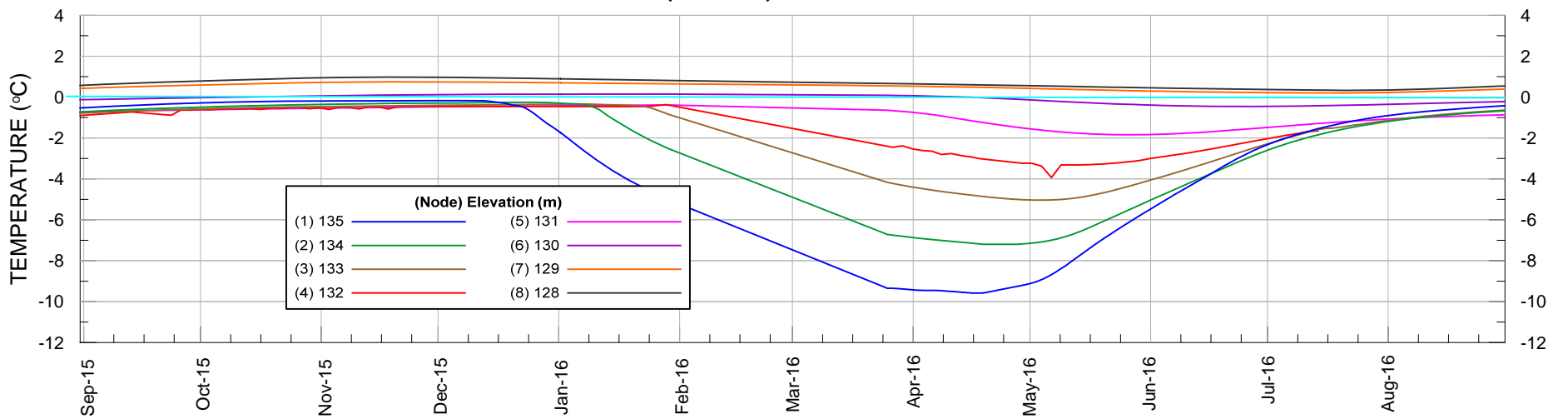

T16 (31+134.5) NODES 9 TO 16

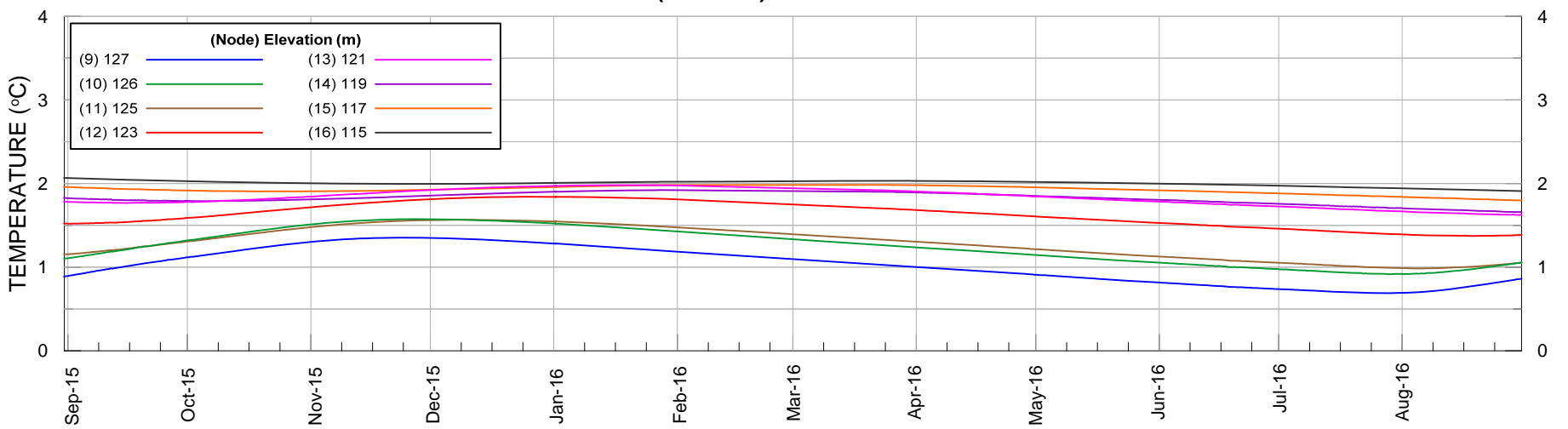

PROJECT		AGNICO EAGLE MINES LIMITED MEADOWBANK GOLD PROJECT NUNAVUT		
TITLE		BAYGOOSE DIKE NODAL THERMAL TIMELINES T15-T16 (Aug 31/15 to Aug 31/16)		
	PROJECT No.		PHASE No.	
	DESIGN	TD	20JAN14	SCALE AS SHOWN
	CADD	TD	20JAN14	REV.
	CHECK			
REVIEW				FIGURE 37

T17 (31+170) NODES 1 TO 8

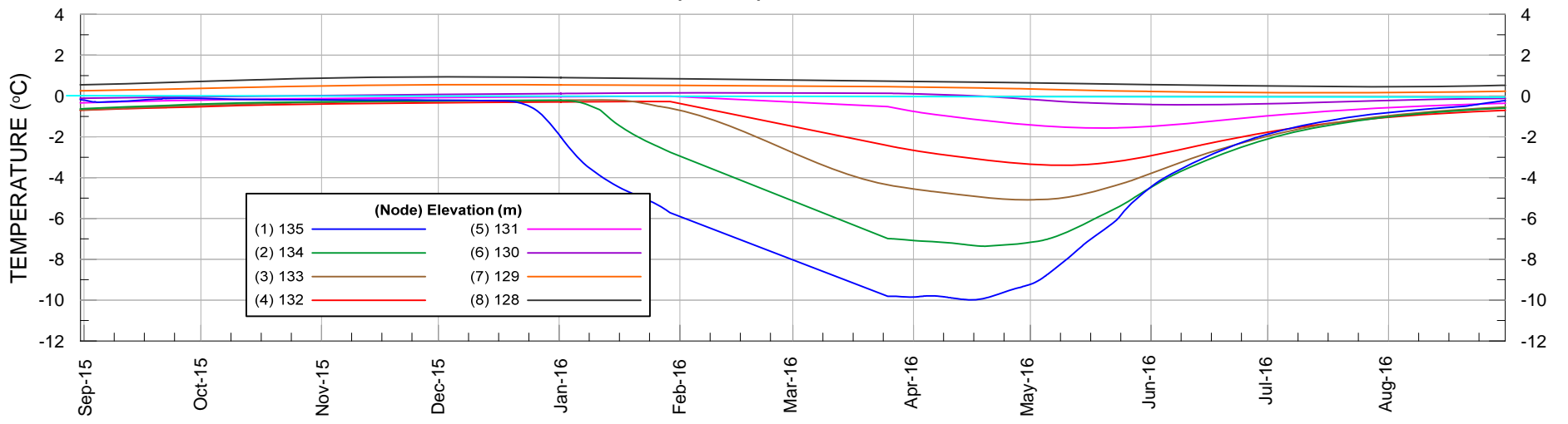

T17 (31+170) NODES 9 TO 16

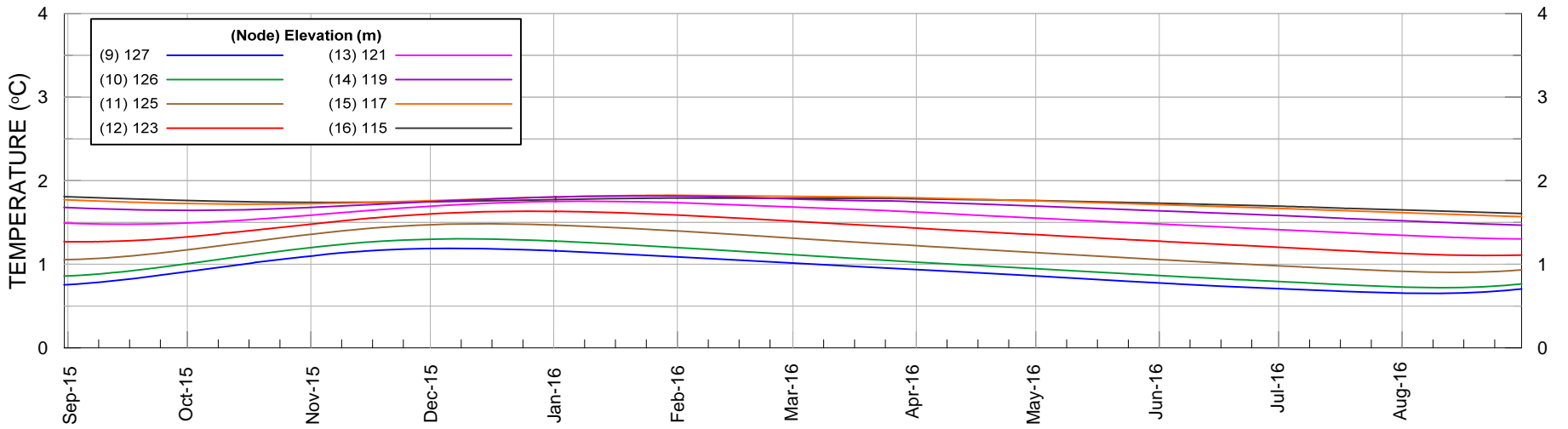

T18 (31+352) NODES 1 TO 8

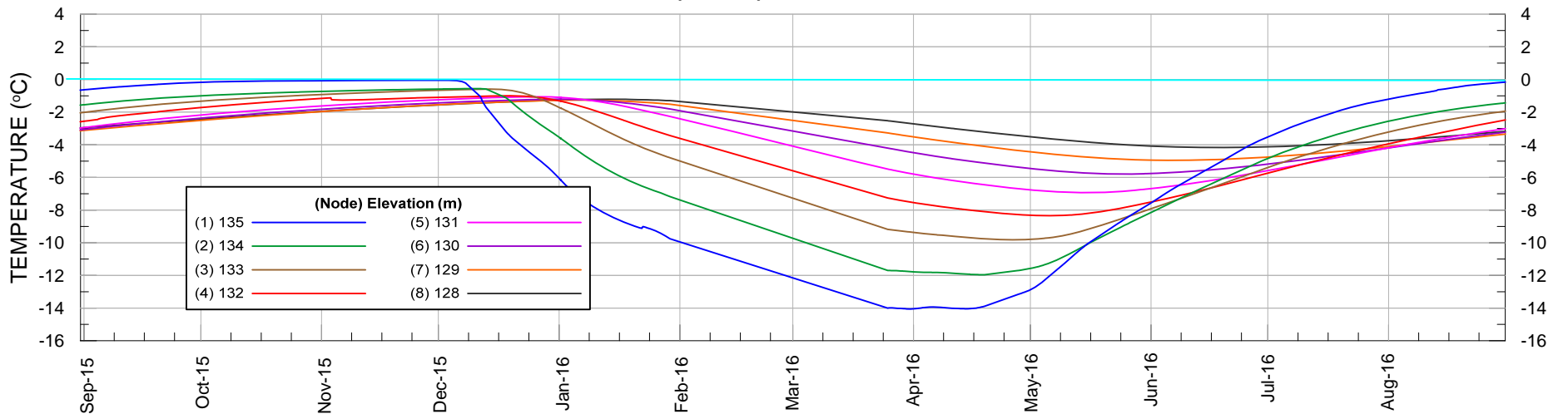

T18 (31+352) NODES 9 TO 16

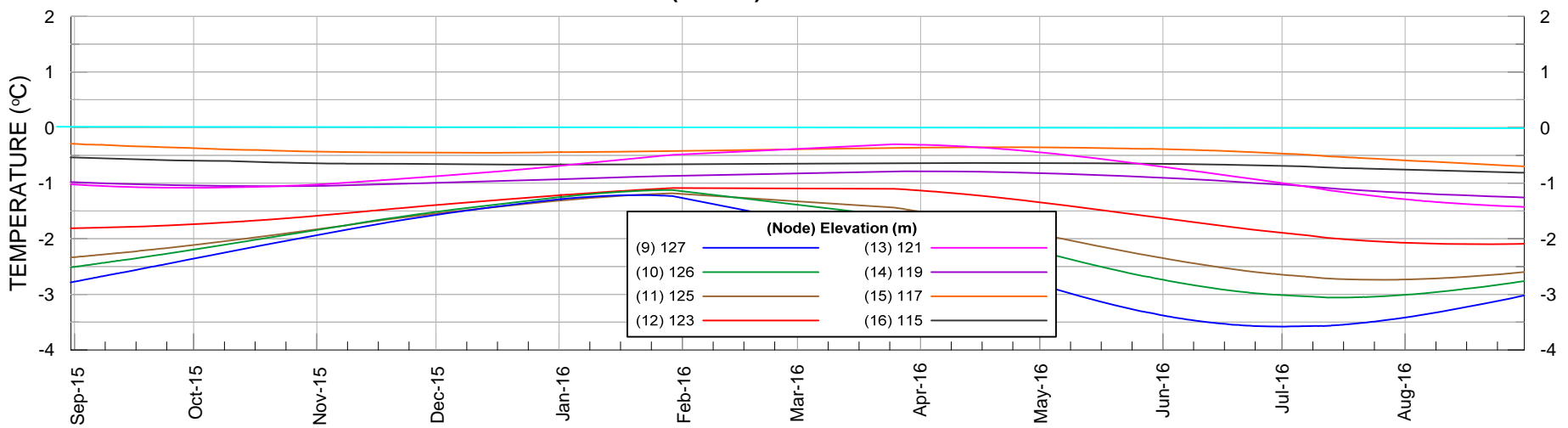

PROJECT		AGNICO EAGLE MINES LIMITED MEADOWBANK GOLD PROJECT NUNAVUT		
TITLE		BAYGOOSE DIKE NODAL THERMAL TIMELINES (Aug 31/15 to Aug 31/16)		
	PROJECT No.		PHASE No.	
	DESIGN	TD	20JAN14	SCALE AS SHOWN
	CADD	TD	20JAN14	REV.
	CHECK			
	REVIEW			
				FIGURE 38

T19 (31+595) NODES 1 TO 8

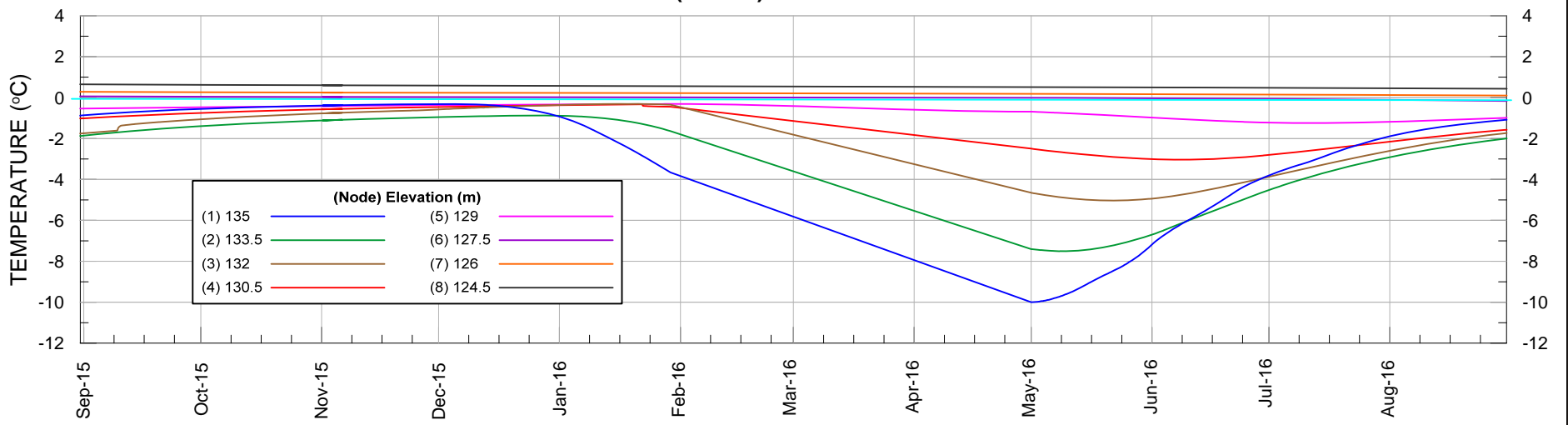

T19 (31+595) NODES 9 TO 16

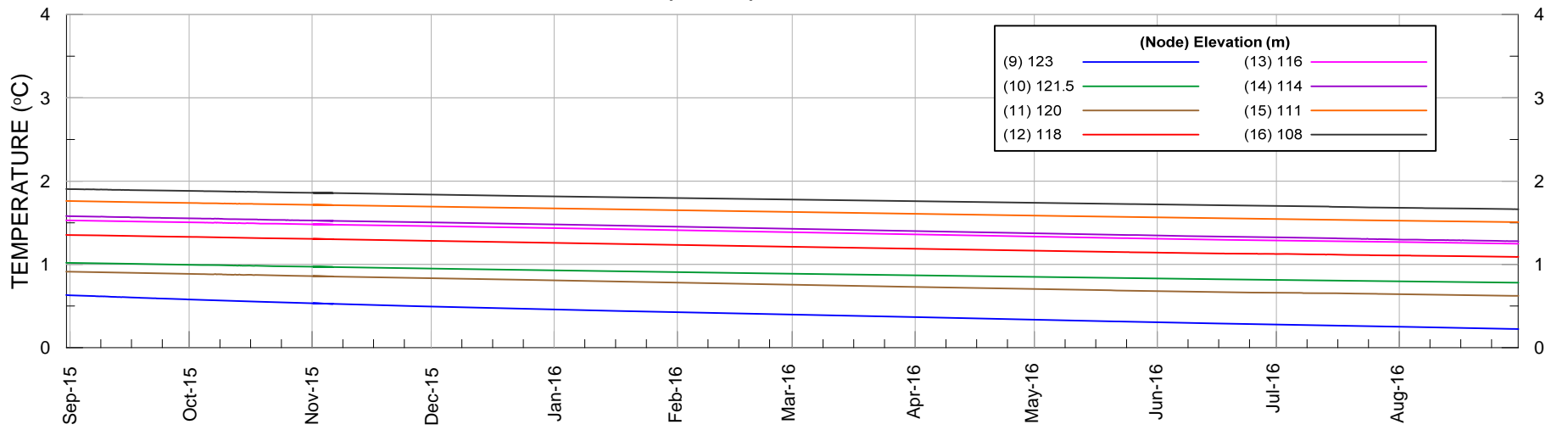

T20 (31+605) NODES 1 TO 8

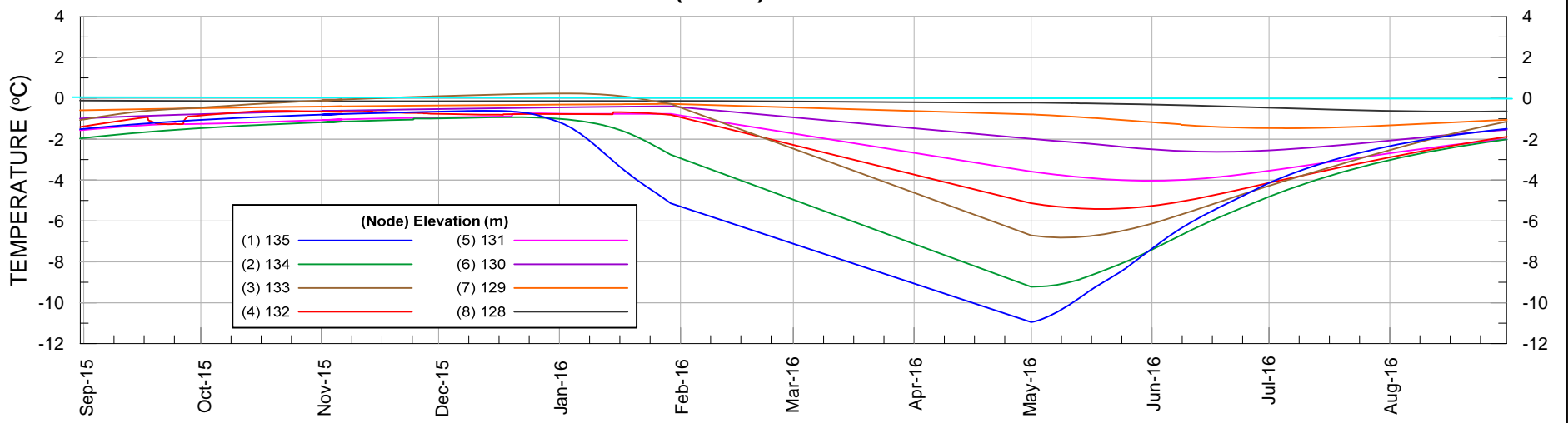

T20 (31+605) NODES 9 TO 16

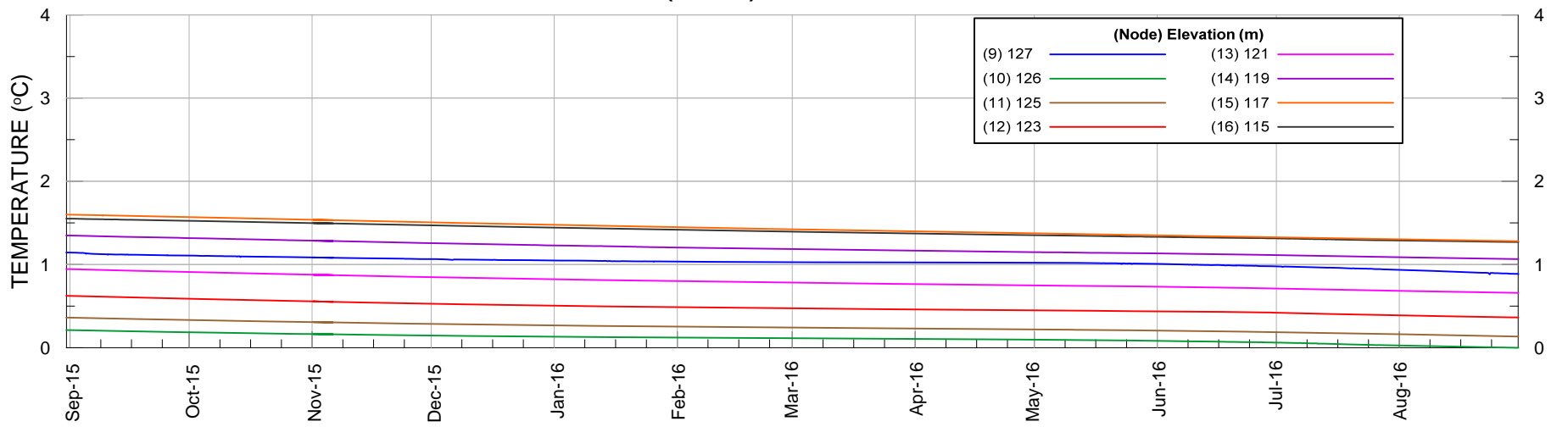

PROJECT		AGNICO EAGLE MINES LIMITED MEADOWBANK GOLD PROJECT NUNAVUT		
TITLE		BAYGOOSE DIKE NODAL THERMAL TIMELINES (Aug 31/15 to Aug 31/16)		
	PROJECT No.	PHASE No.		
	DESIGN TD 20JAN14	SCALE AS SHOWN	REV.	
	CADD TD 20JAN14	FIGURE 39		
	CHECK			
REVIEW				

T21 (31+752.5) NODES 1 TO 8

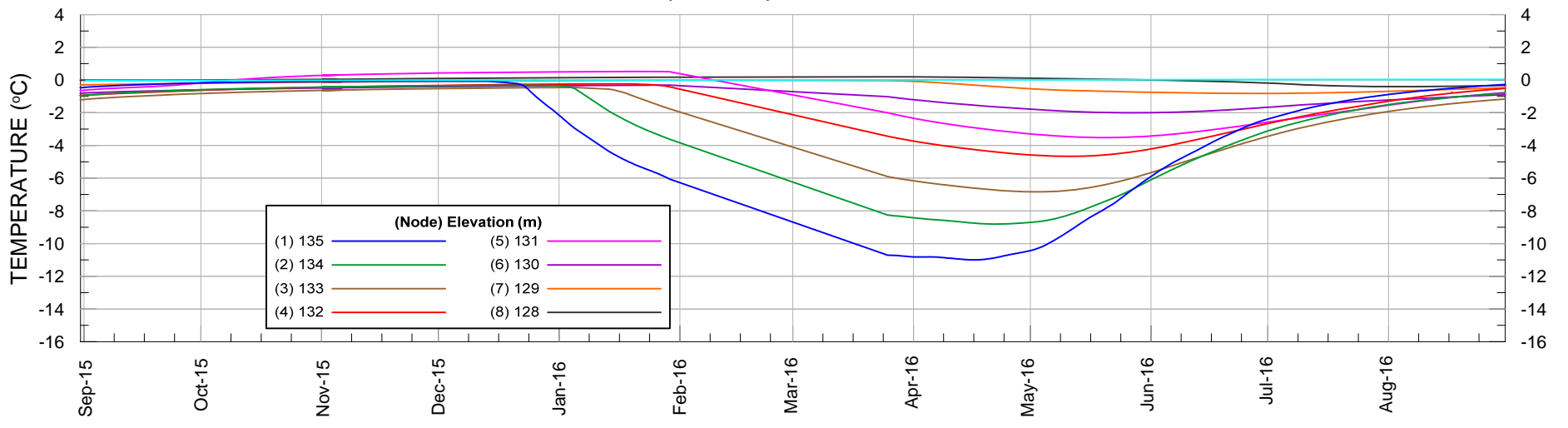

T21 (31+752.5) NODES 9 TO 16

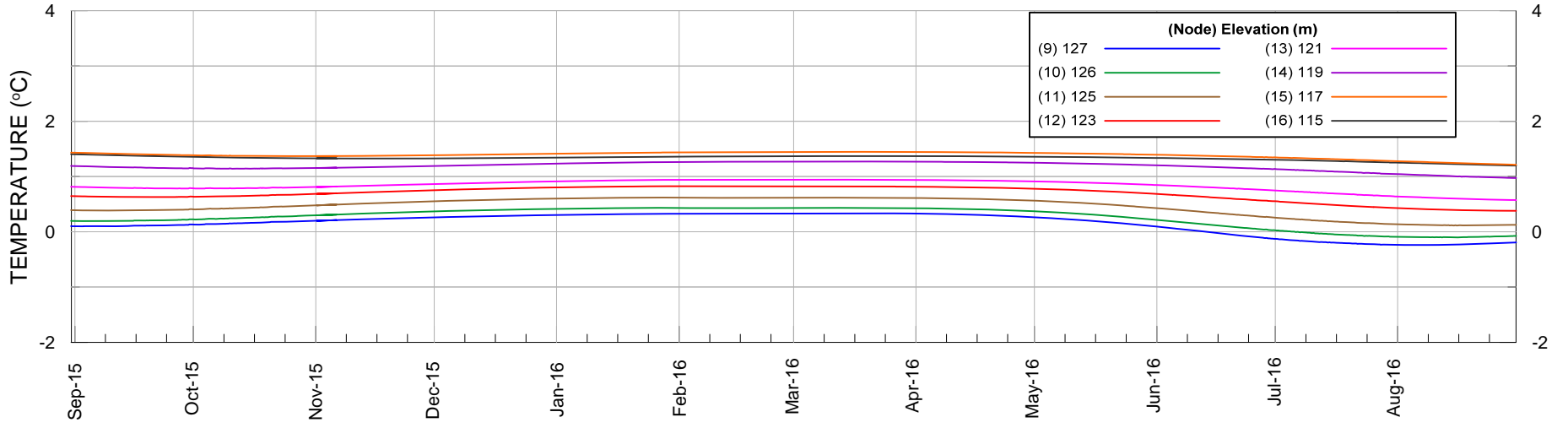

T22 (31+820) NODES 1 TO 8

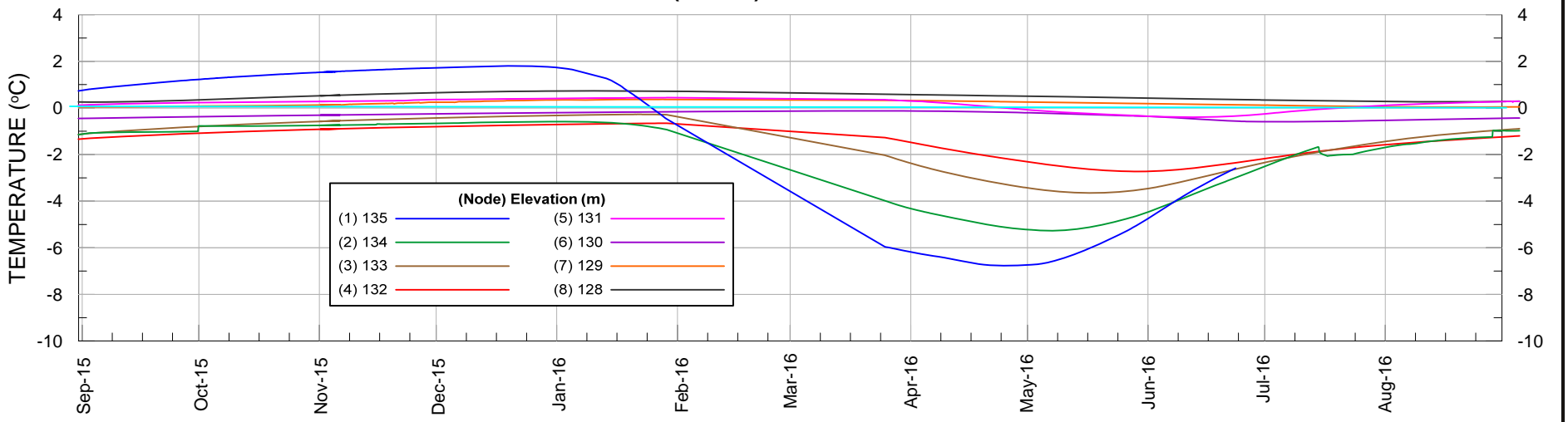

T22 (31+820) NODES 9 TO 16

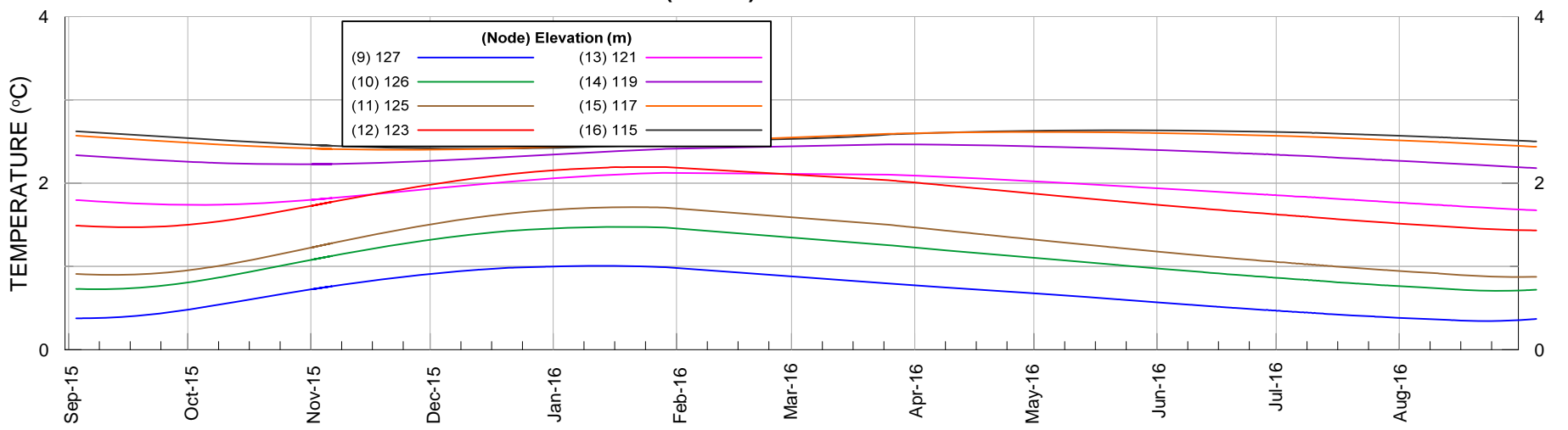

PROJECT		AGNICO EAGLE MINES LIMITED MEADOWBANK GOLD PROJECT NUNAVUT		
TITLE		BAYGOOSE DIKE NODAL THERMAL TIMELINES (Aug 31/15 to Aug 31/16)		
	PROJECT No.	PHASE No.		
	DESIGN TD 20JAN14	SCALE	AS SHOWN	
	CADD TD 20JAN14	REV.		
	CHECK	FIGURE 40		
REVIEW				

T23 (31+850) NODES 1 TO 8

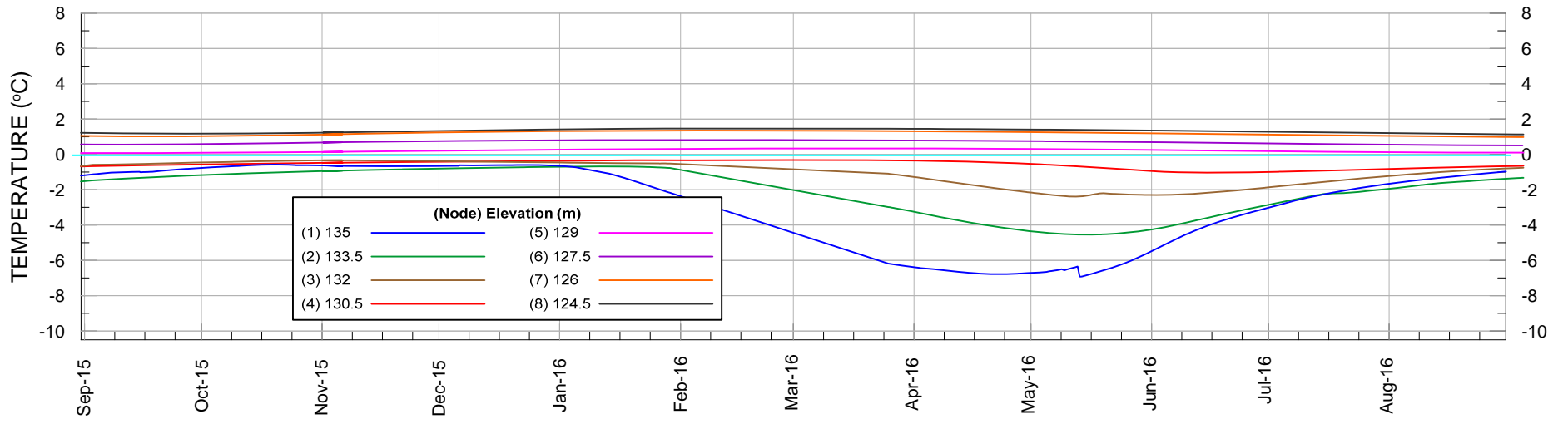

T23 (31+850) NODES 9 TO 16

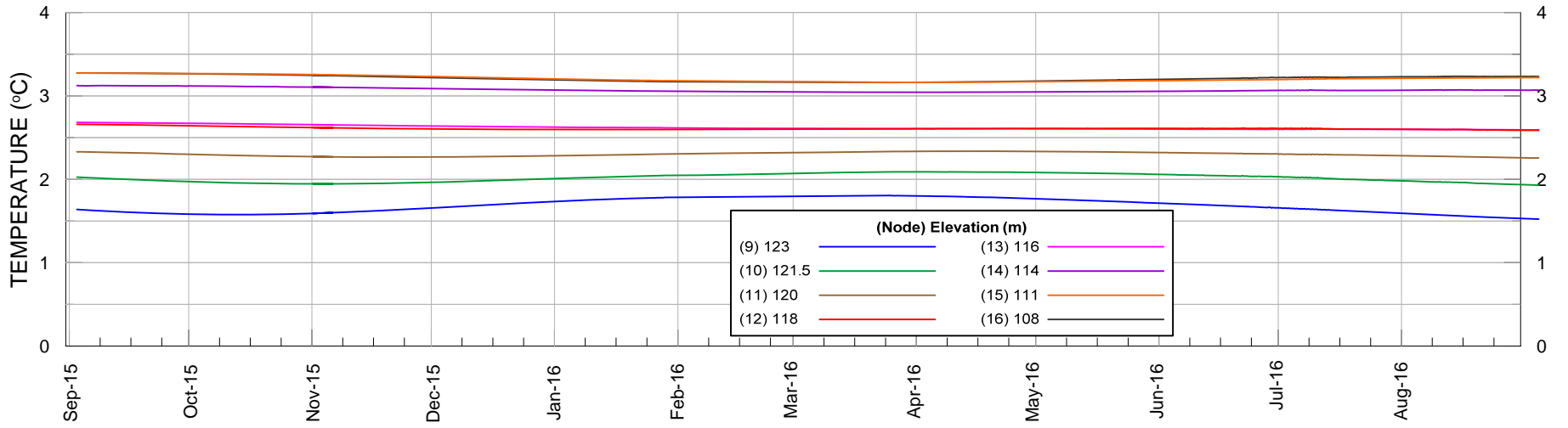

T24 (31+880) NODES 1 TO 8

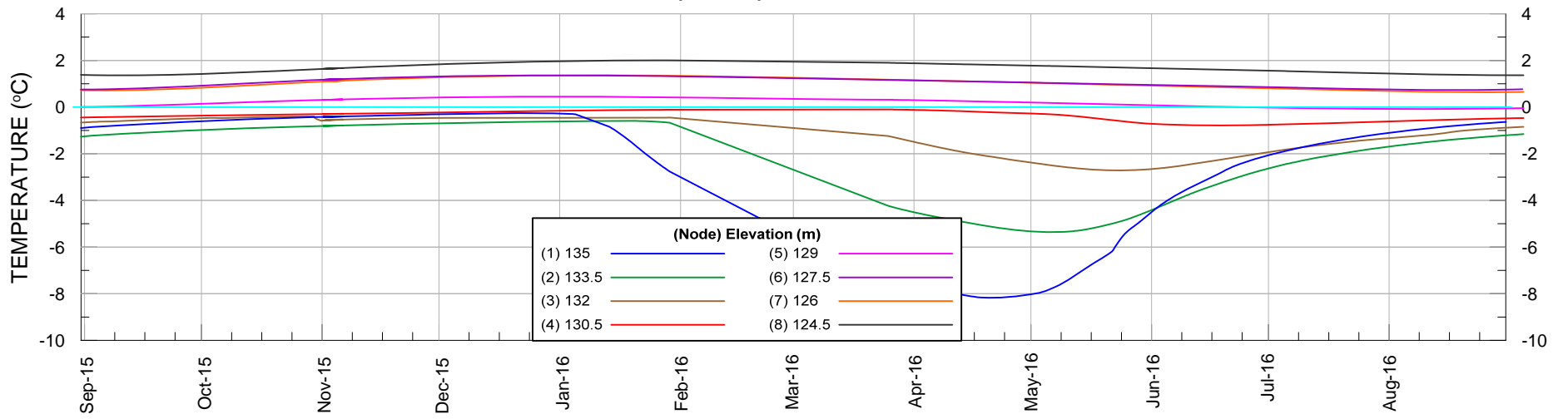

T24 (31+880) NODES 9 TO 16

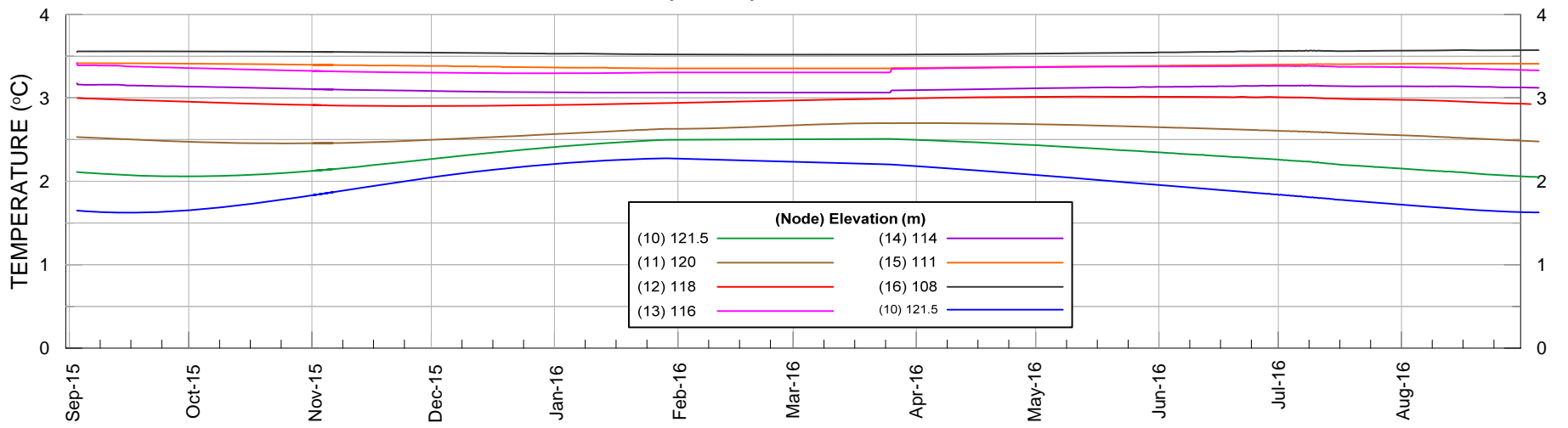

PROJECT	AGNICO EAGLE MINES LIMITED MEADOWBANK GOLD PROJECT NUNAVUT				
TITLE	BAYGOOSE DIKE NODAL THERMAL TIMELINES Aug 31/15 to Aug 31/16				
	PROJECT No.		PHASE No.		
	DESIGN	TD	20JAN14	SCALE	AS SHOWN
	CADD	TD	20JAN14	REV.	
	CHECK			FIGURE 41	
REVIEW					

T25 (31+960) NODES 1 TO 8

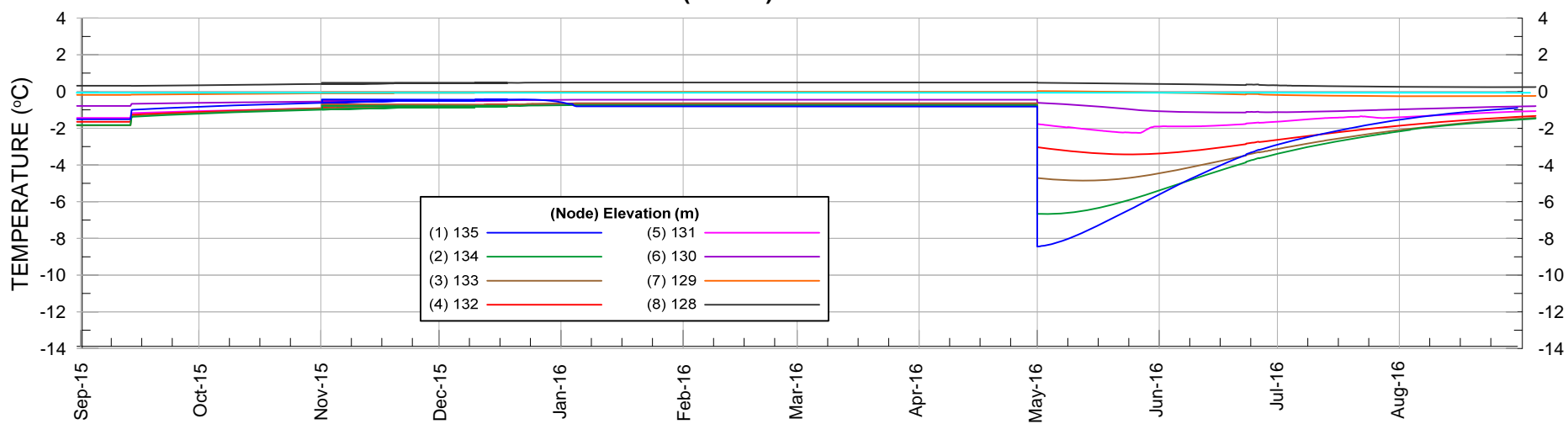

T25 (31+960) NODES 9 TO 16

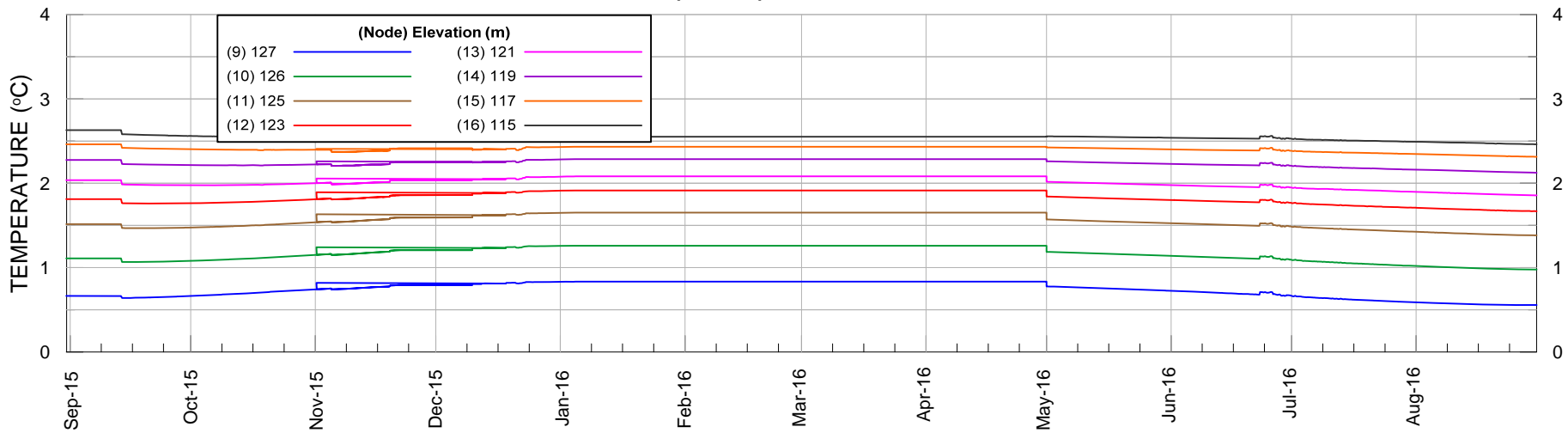

T26 (31+995) NODES 1 TO 8

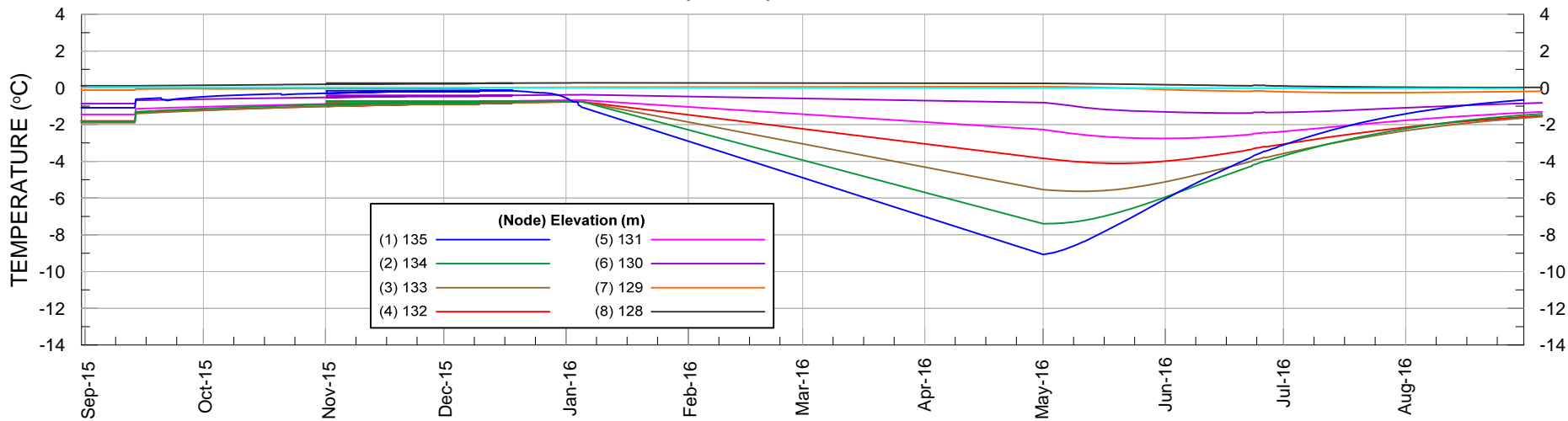

T26 (31+995) NODES 9 TO 16

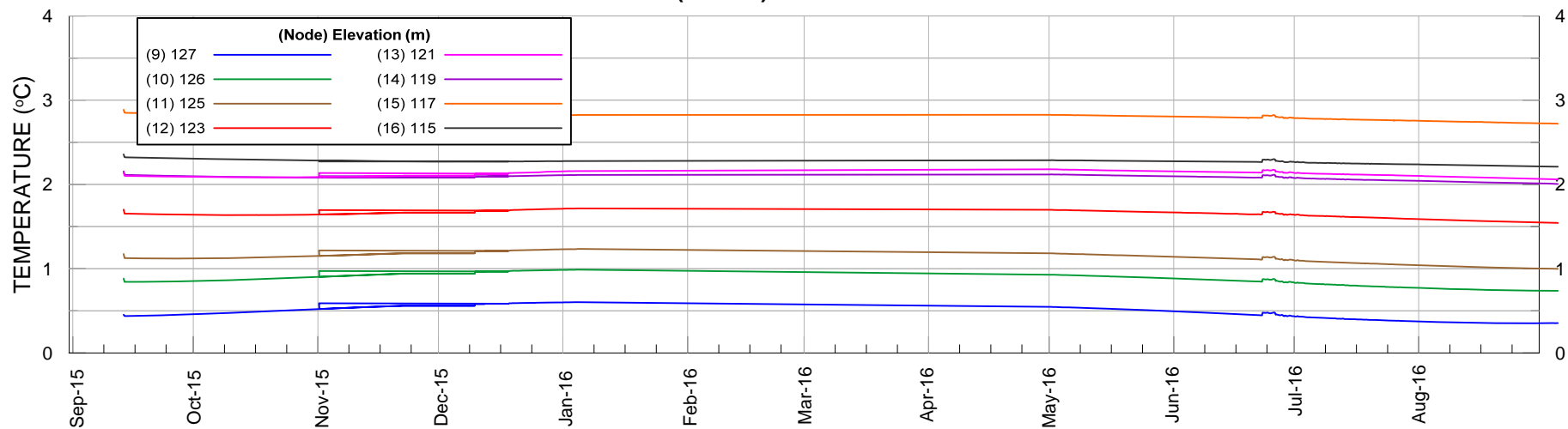

PROJECT		AGNICO EAGLE MINES LIMITED MEADOWBANK GOLD PROJECT NUNAVUT		
TITLE		BAYGOOSE DIKE NODAL THERMAL TIMELINES (Aug 31/15 to Aug 31/16)		
	PROJECT No.		PHASE No.	
	DESIGN	TD	20JAN14	SCALE AS SHOWN
	CADD	TD	20JAN14	REV.
	CHECK			
REVIEW				FIGURE 42

T27 (32+030) NODES 1 TO 8

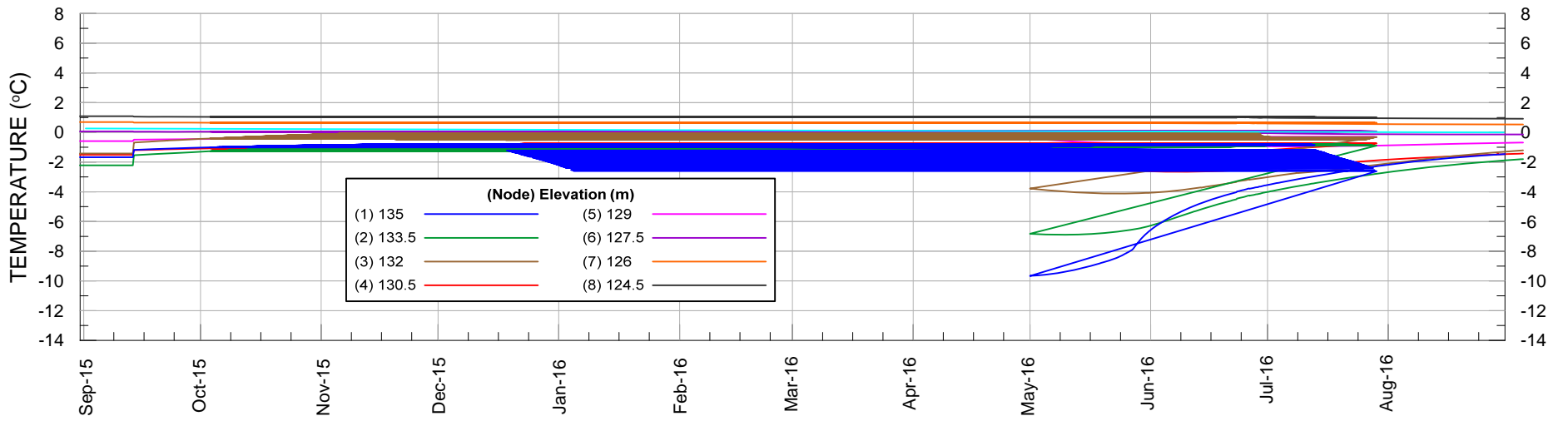

T27 (32+030) NODES 9 TO 16

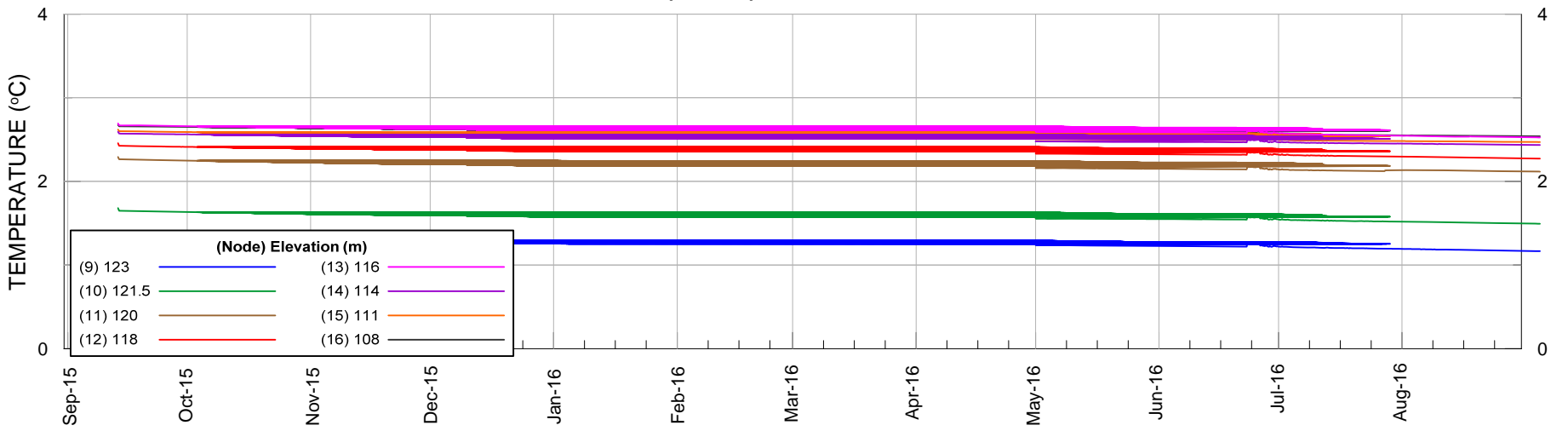

T28 (32+060) NODES 1 TO 8

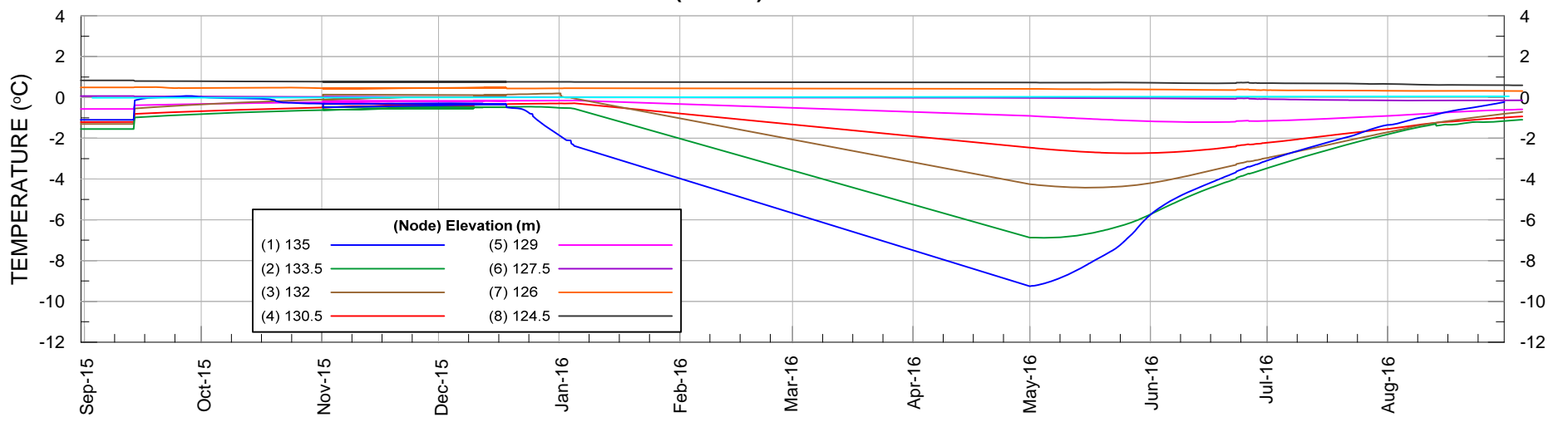

T28 (32+060) NODES 9 TO 16

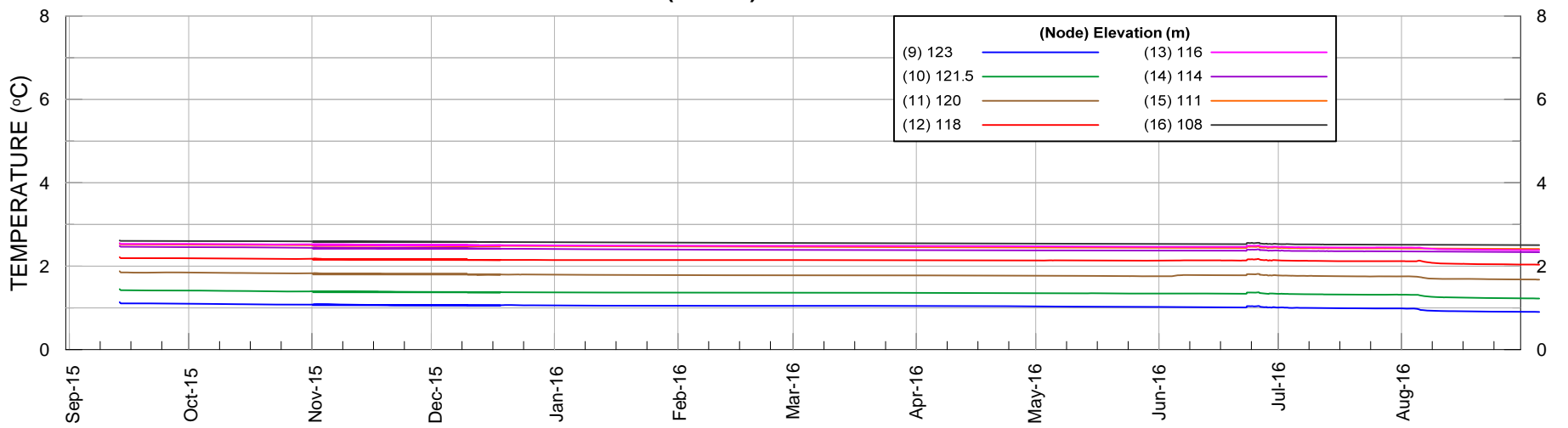

PROJECT		AGNICO EAGLE MINES LIMITED MEADOWBANK GOLD PROJECT NUNAVUT		
TITLE		BAYGOOSE DIKE NODAL THERMAL TIMELINES (Aug 31/15 to Aug 31/16)		
	PROJECT No.		PHASE No.	
	DESIGN	TD	17JAN14	SCALE AS SHOWN
	CADD	TD	17JAN14	REV.
	CHECK			
REVIEW				FIGURE 43

T29 (32+100) NODES 1 TO 8

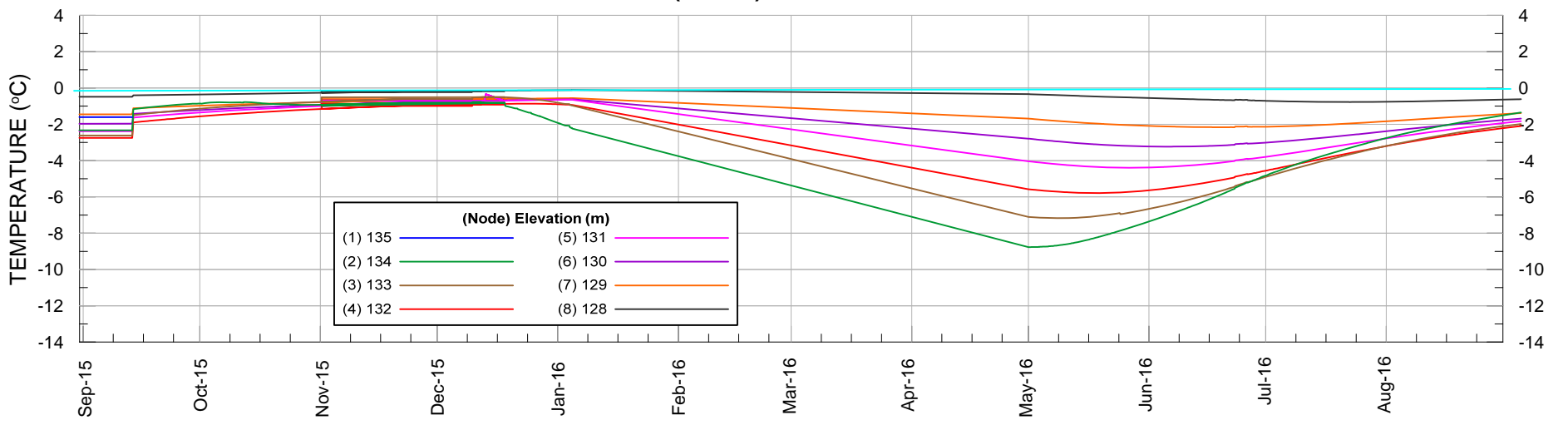

T29 (32+100) NODES 9 TO 16

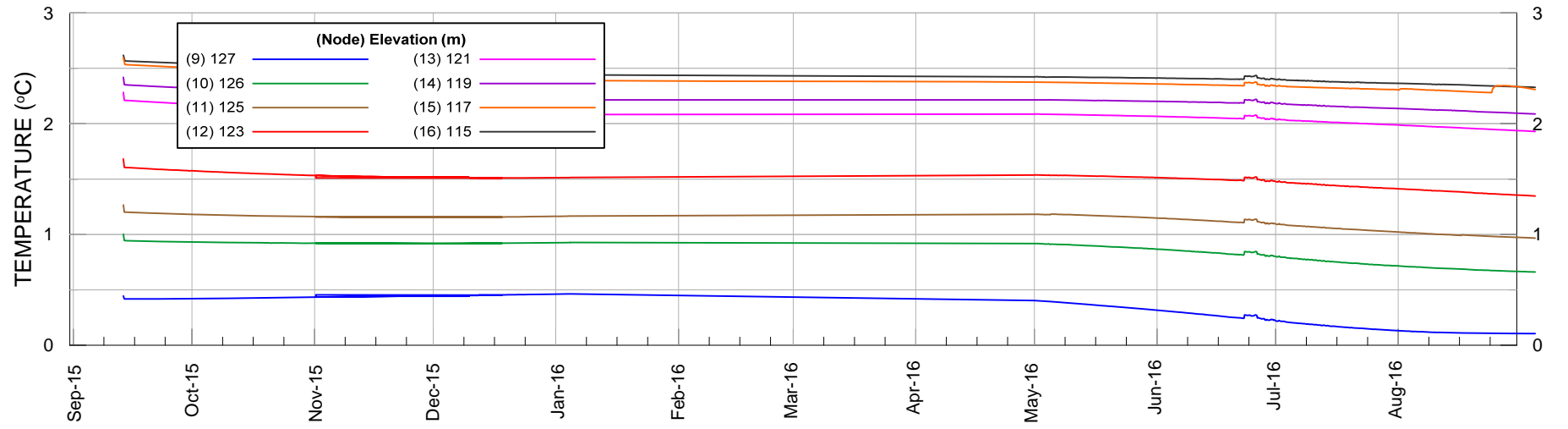

T30 (32+140) NODES 1 TO 8

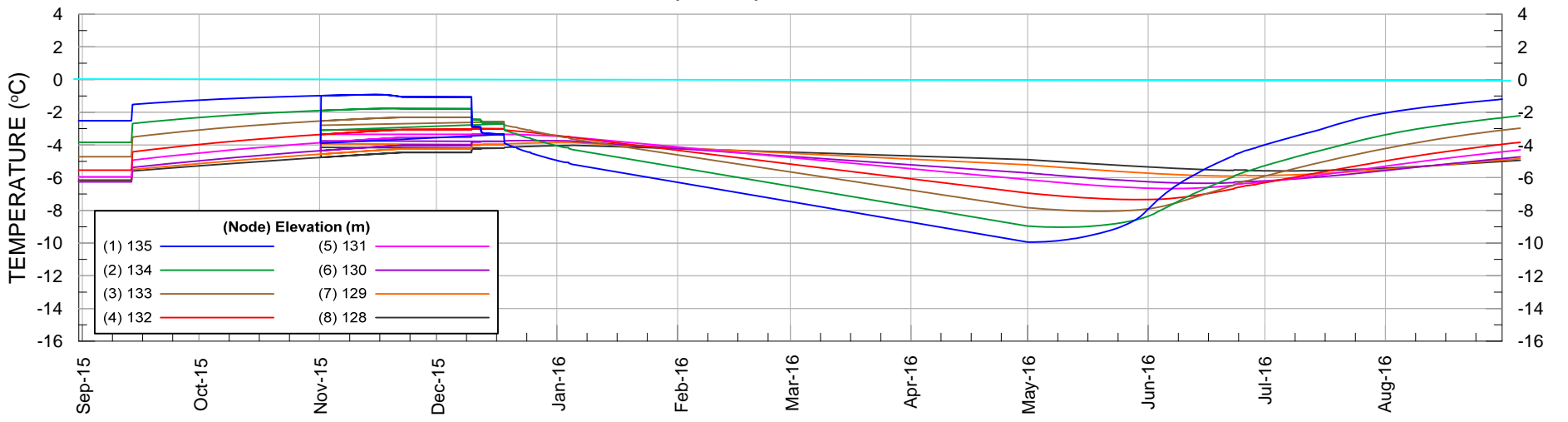

T30 (32+140) NODES 9 TO 16

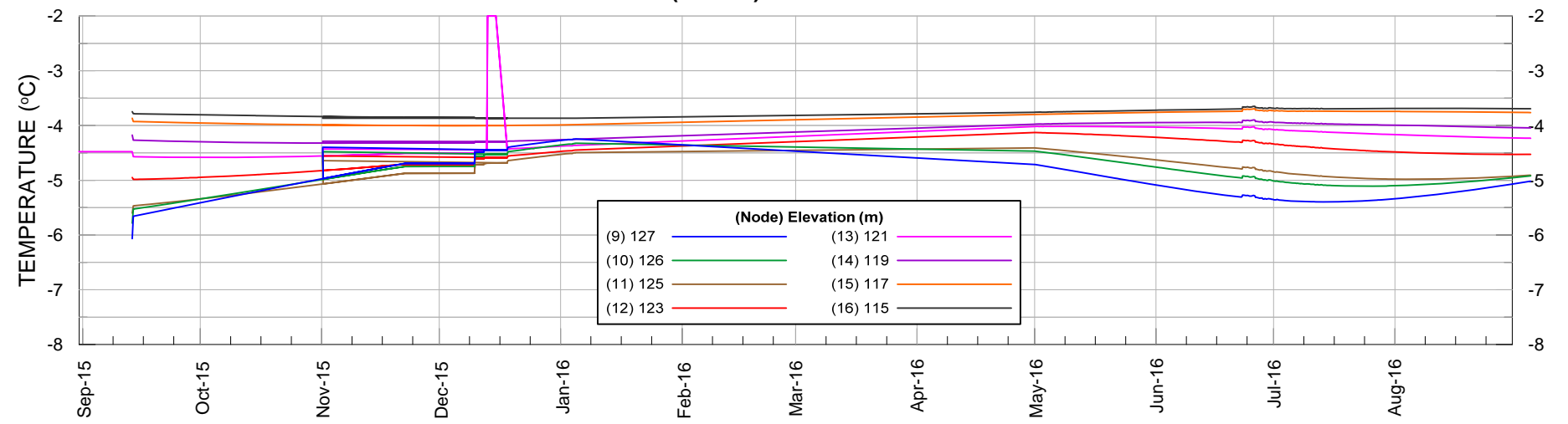

PROJECT **AGNICO EAGLE MINES LIMITED
MEADOWBANK GOLD PROJECT
NUNAVUT**

TITLE **BAYGOOSE DIKE
NODAL THERMAL TIMELINES
(Aug 31/15 to Aug 31/16)**



PROJECT No.			PHASE No.		
DESIGN	TD	17JAN14	SCALE	AS SHOWN	REV.
CADD	TD	17JAN14	FIGURE 44		
CHECK					
REVIEW					

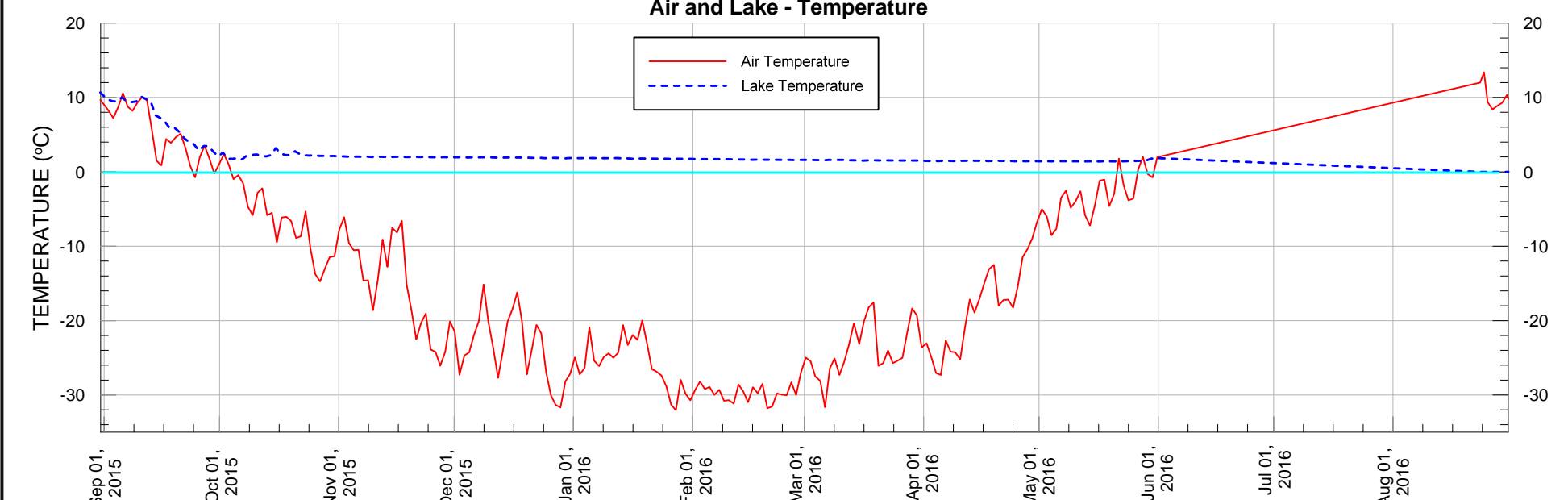
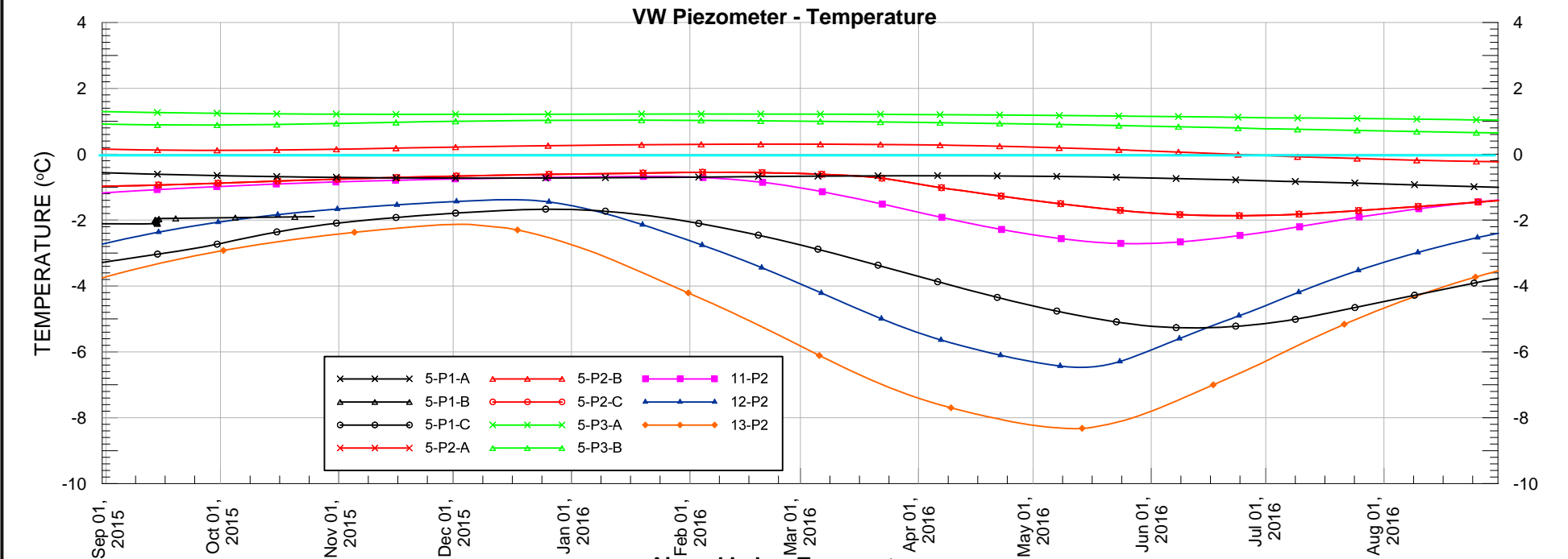
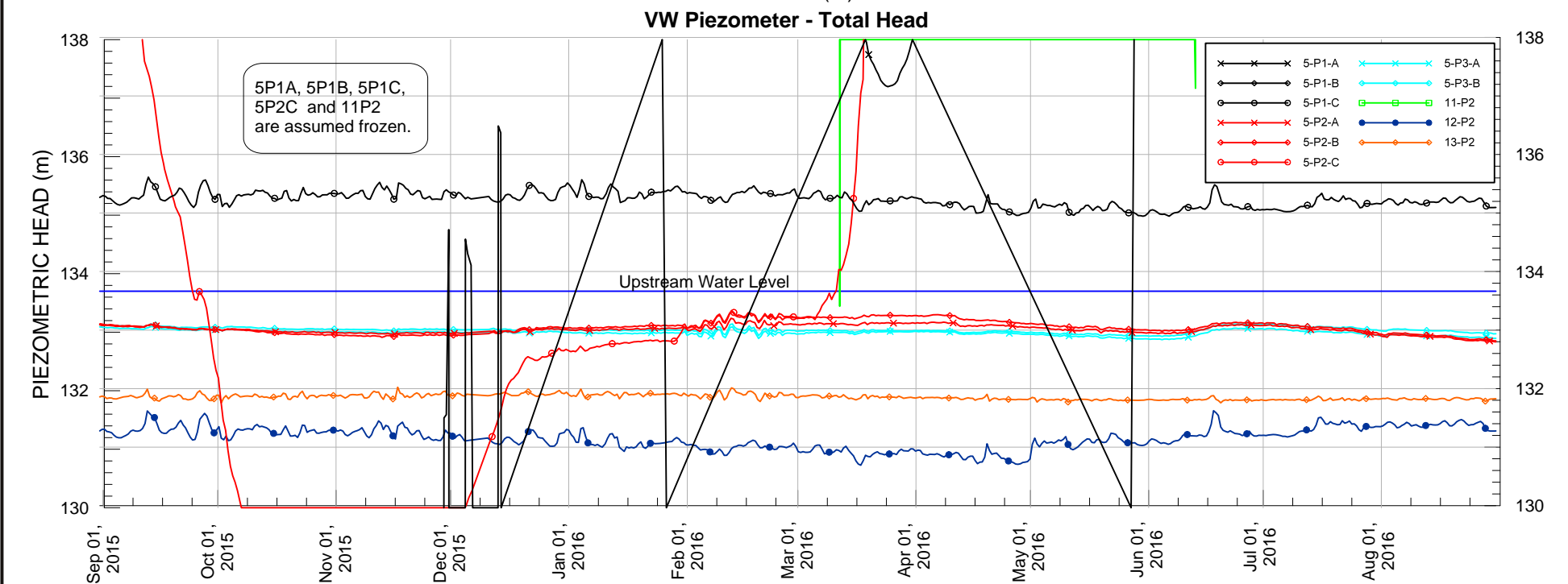
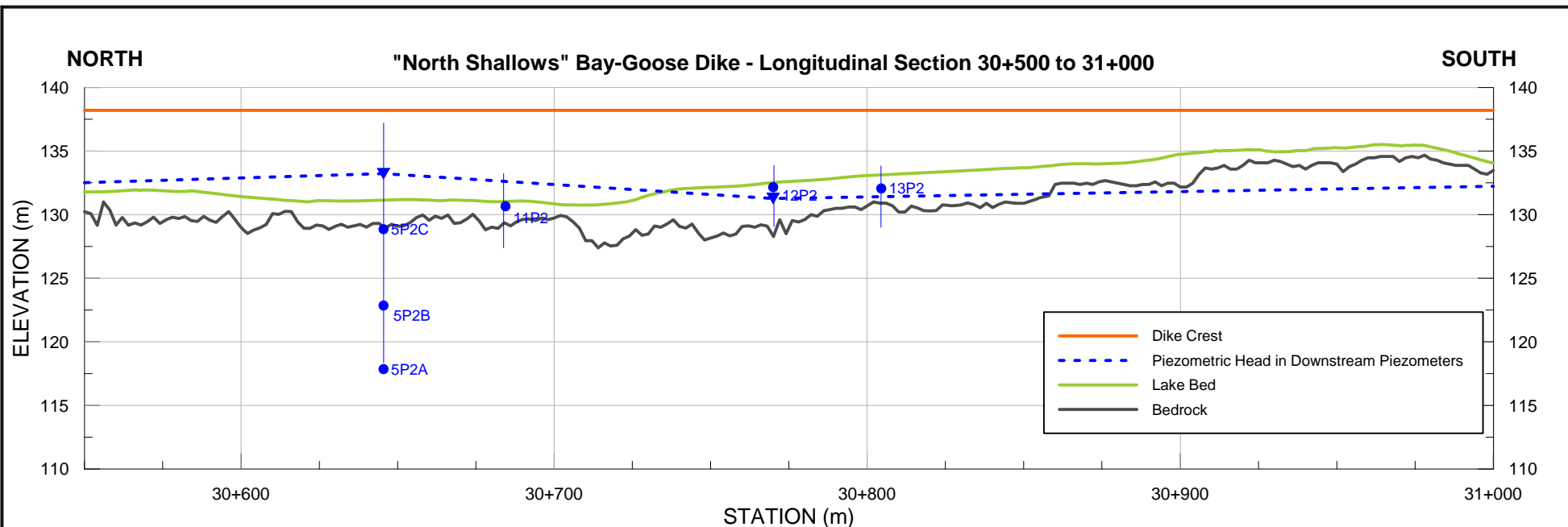

PROJECT	AGNICO EAGLE MINES LIMITED MEADOWBANK GOLD PROJECT NUNAVUT				
TITLE	BAYGOOSE DIKE 30+550 to 31+000 - PIEZOMETRIC DATA (Aug 31/15 to Aug 31/16)				
	PROJECT No.	09-1428-5007	PHASE No.	4000	
	DESIGN	TD	28AUG14	SCALE	AS SHOWN
	CADD	PG	28AUG14	REV.	
	CHECK	PG	28AUG14	FIGURE 9	
REVIEW					

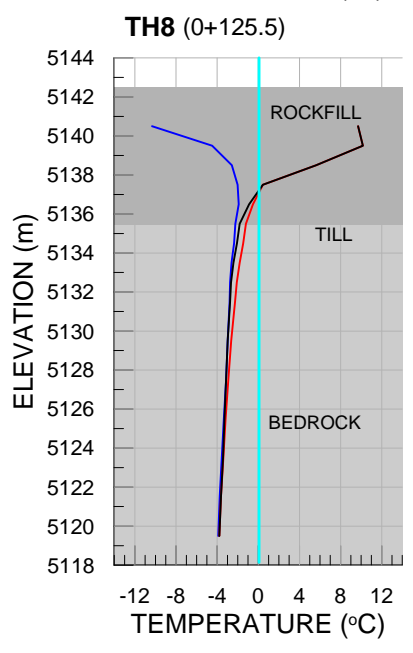
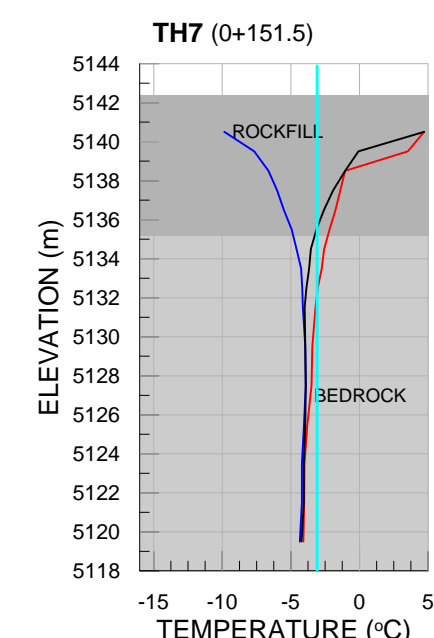
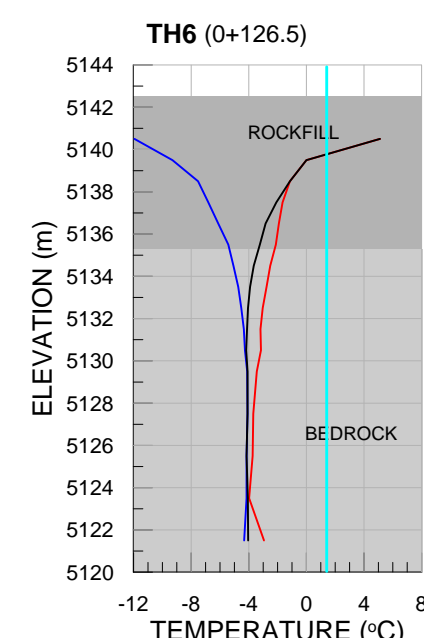
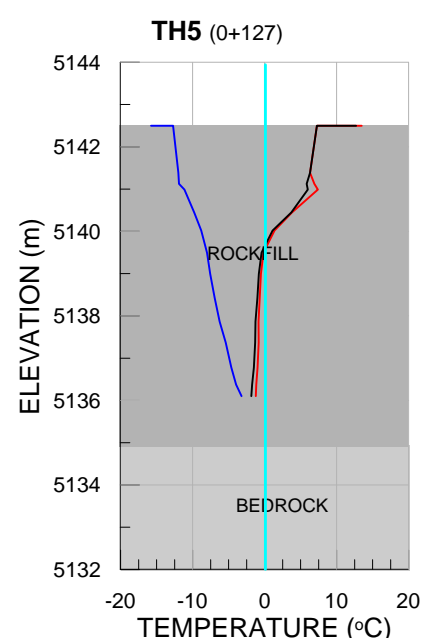
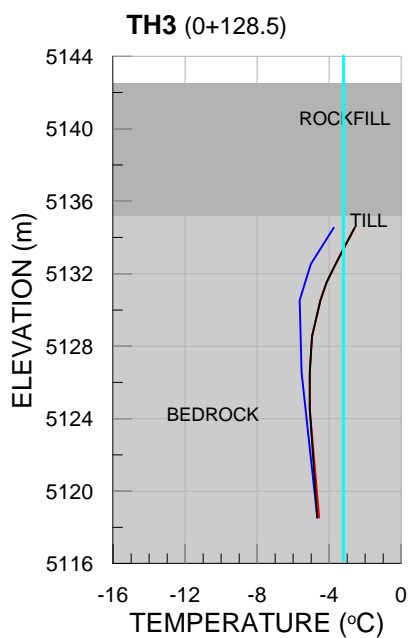
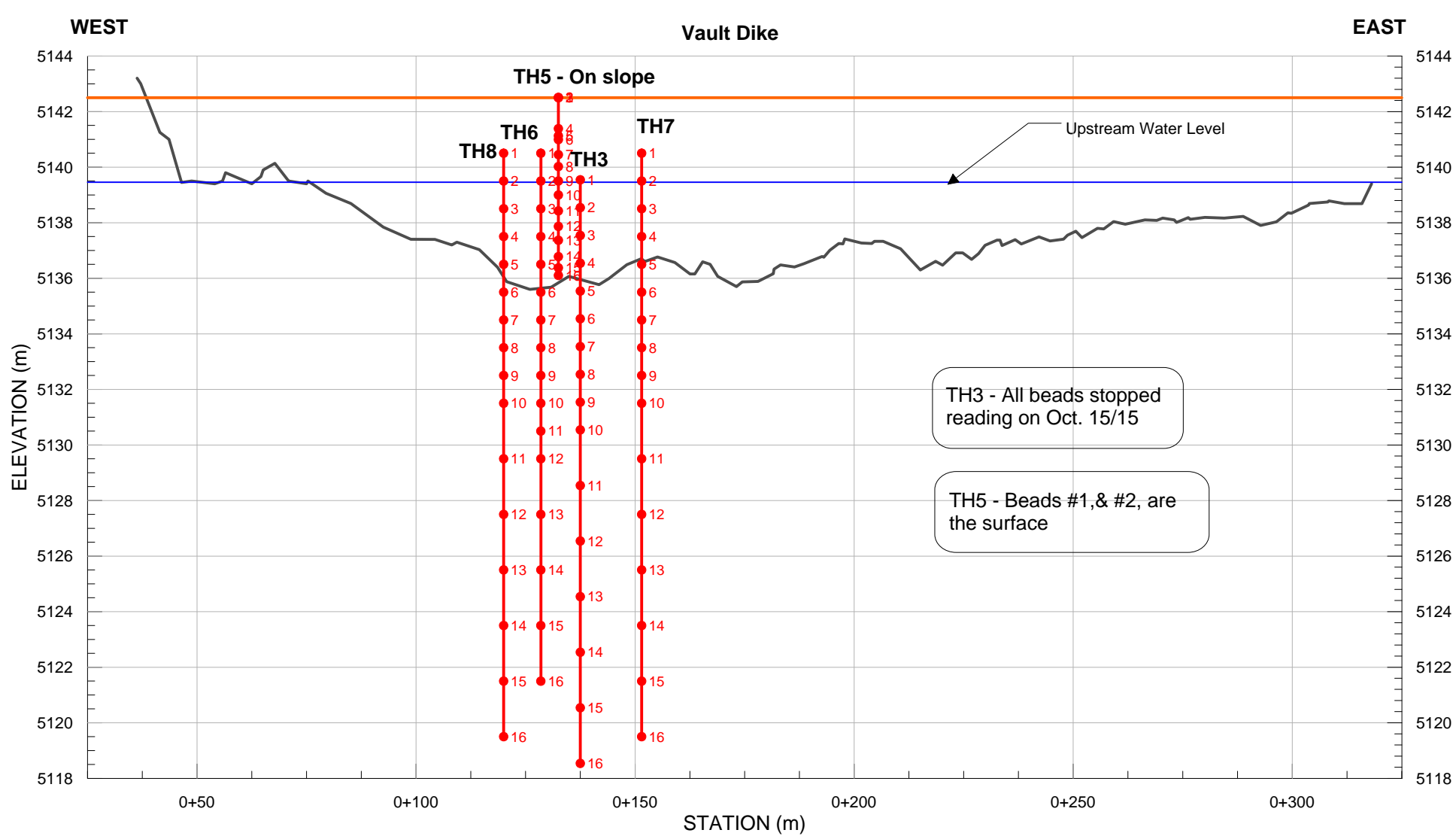

LEGEND

- Dike Crest
- Lake Bed
- Bedrock
- T min
- T current
- T max
- Lake
- Till
- Bedrock
- 6, 7, 8, 9 Thermistor with Bead Locations

PROJECT		AGNICO EAGLE MINES LIMITED MEADOWBANK GOLD PROJECT NUNAVUT		
TITLE		VAULT DIKE TEMPERATURE DATA (Aug 31/15 to Aug 31/16)		
	PROJECT No.	PHASE No.		
	DESIGN TD 28AUG14	SCALE	AS SHOWN REV.	
	CADD TD 28AUG14	FIGURE 54		
	CHECK PG 28AUG14			
REVIEW				

VD-TH3 (71-1)

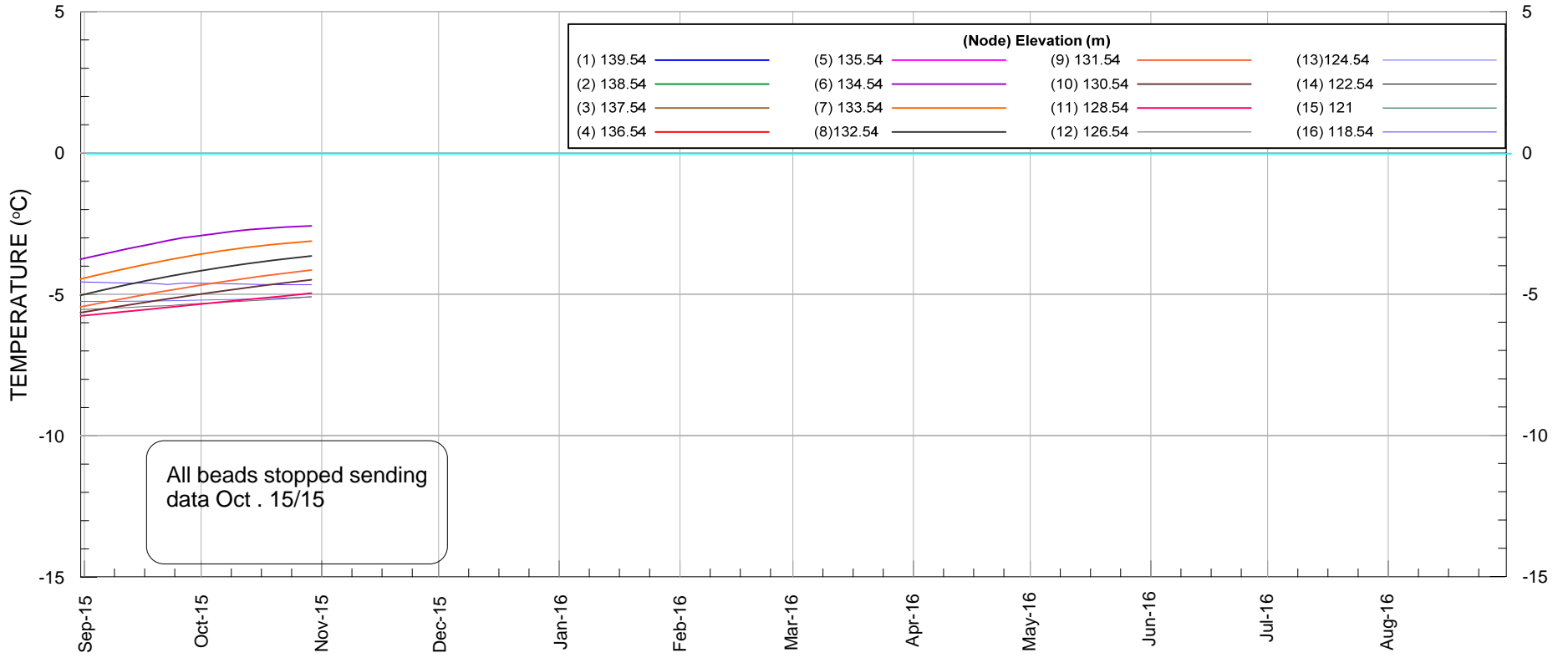

VD-TH5 (71-2) - Installed on slope of the liner

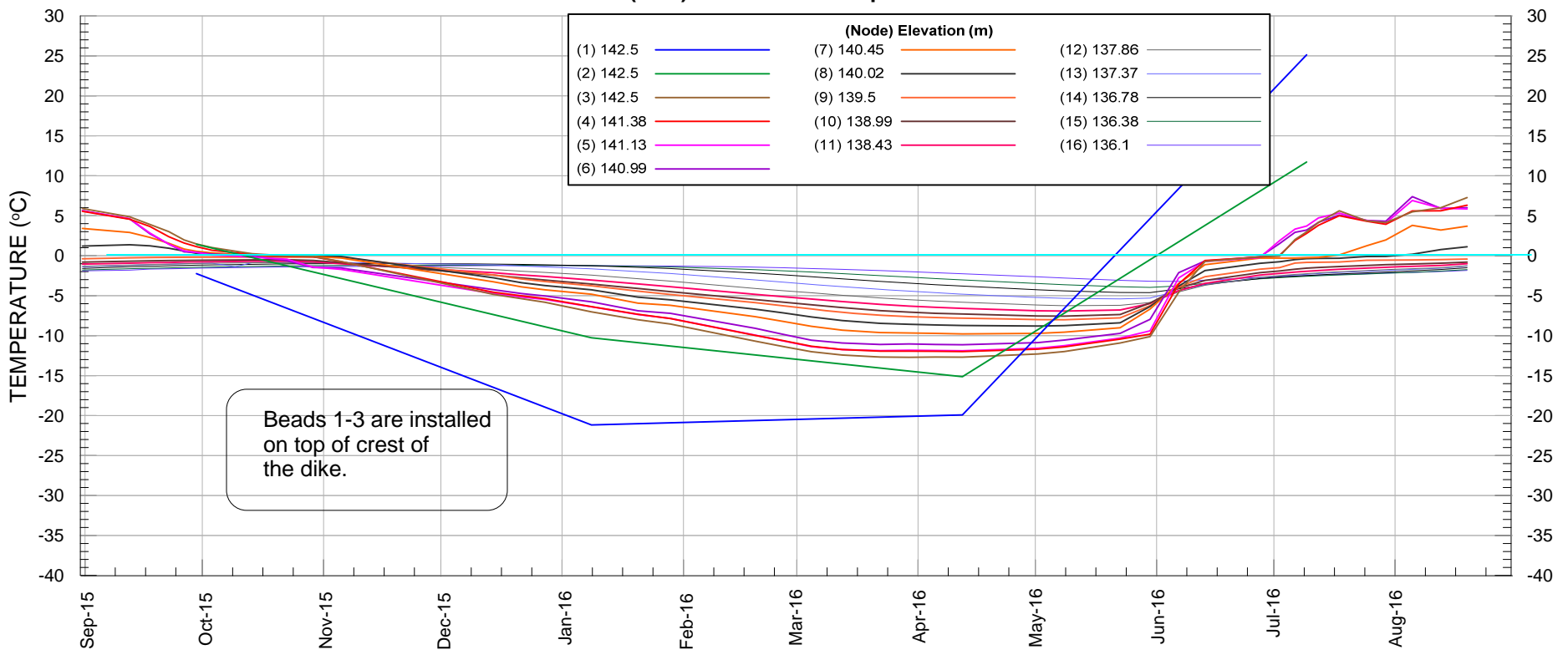

VD-TH6 (94-2)

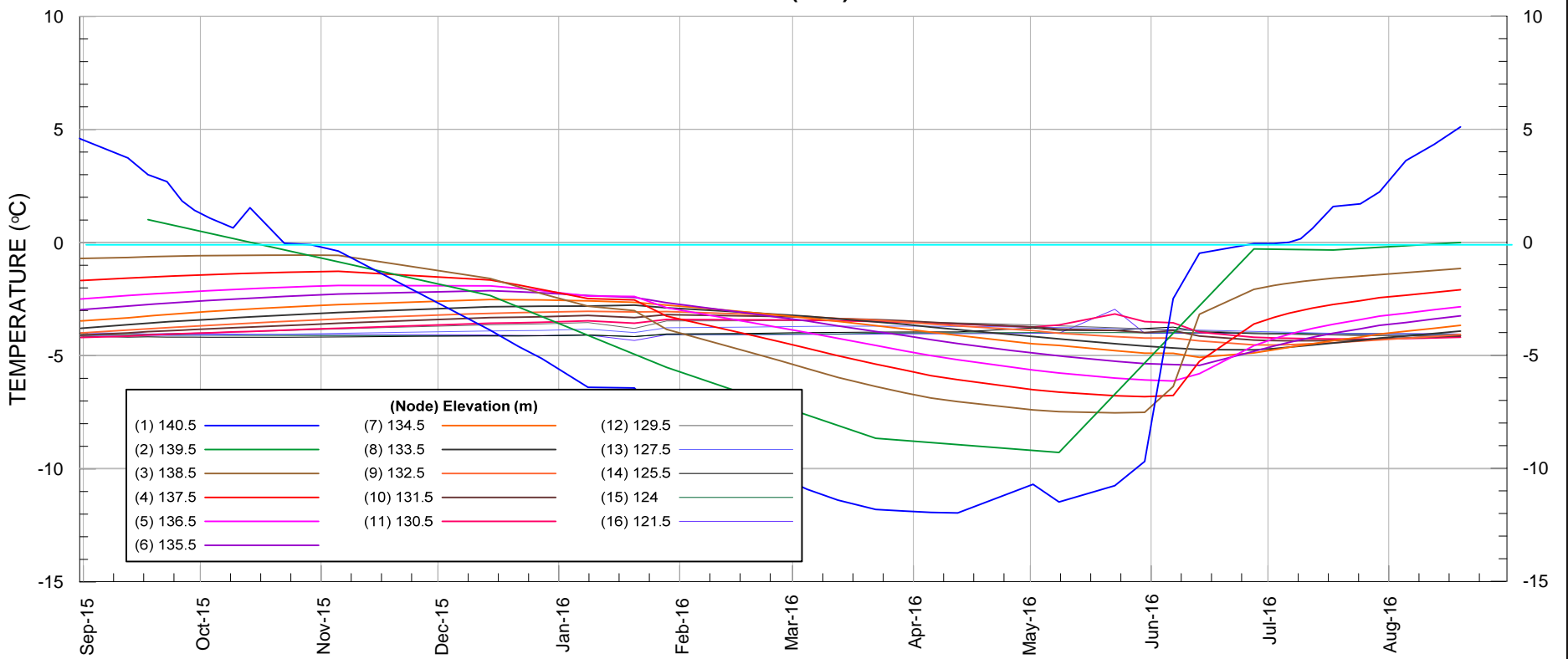

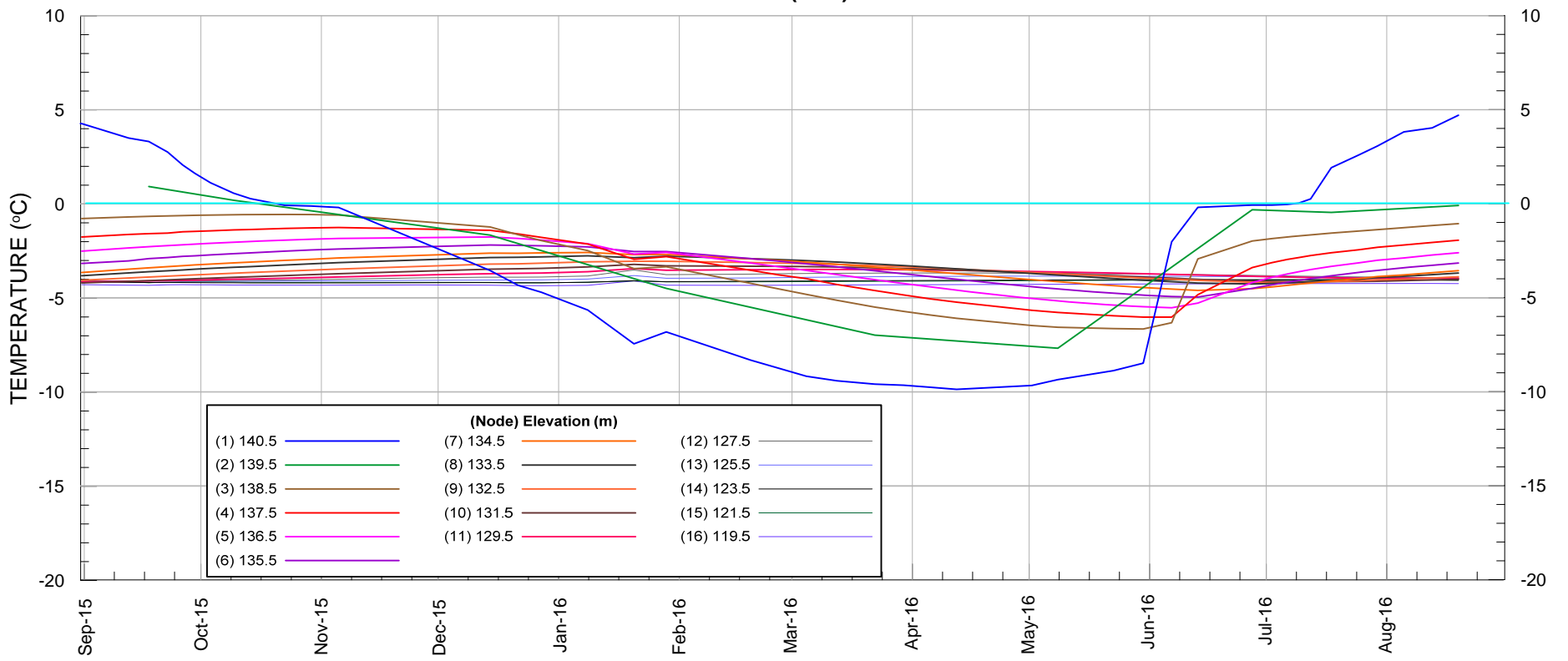

PROJECT		AGNICO EAGLE MINES LIMITED MEADOWBANK GOLD PROJECT NUNAVUT		
TITLE		VAULT DIKE NODAL THERMAL TIMELINES (Aug 31/15 to Aug 31/16)		
	PROJECT No.		PHASE No.	
	DESIGN	TD	28AUG14	SCALE AS SHOWN
	CADD	TD	28AUG14	REV.
	CHECK	PG	28AUG14	FIGURE 55
REVIEW				

VD-TH7 (96-2)

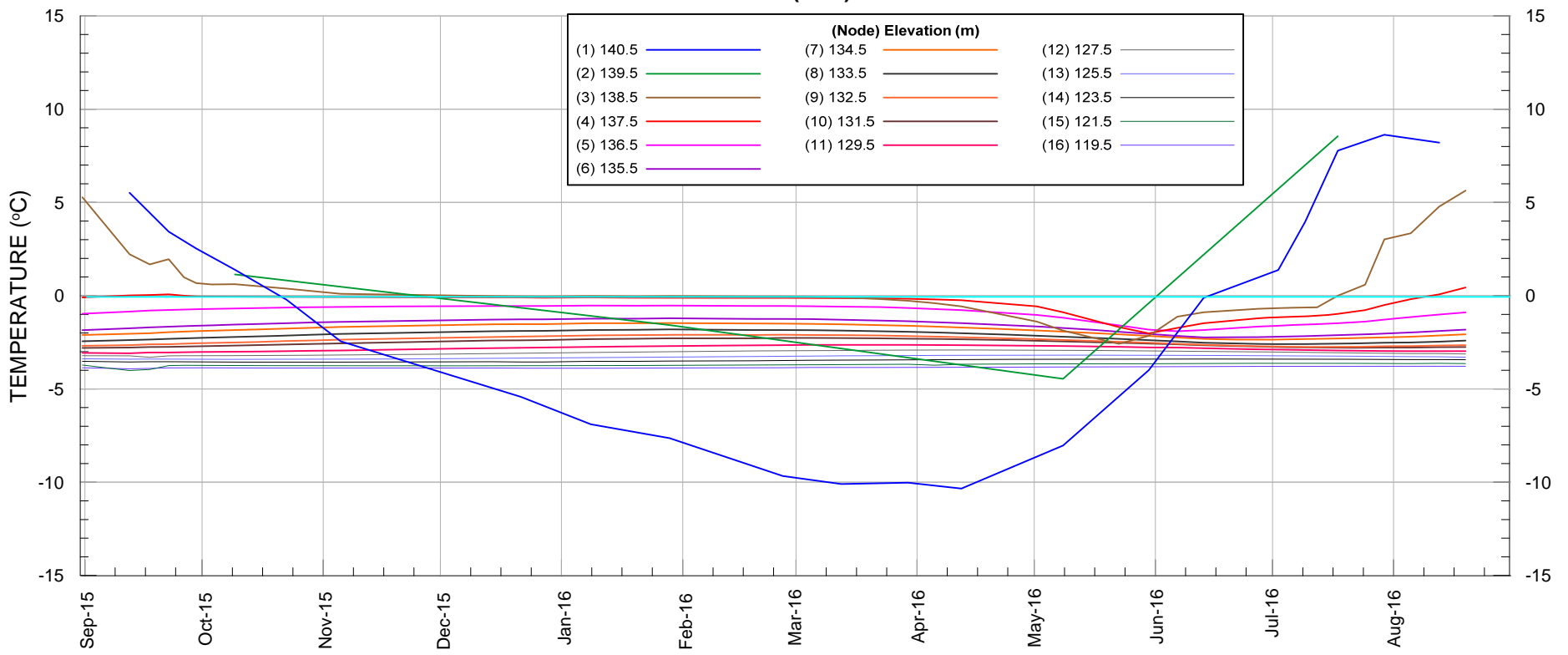

VD-TH8 (96-1)



PROJECT		AGNICO EAGLE MINES LIMITED MEADOWBANK GOLD PROJECT NUNAVUT		
TITLE		VAULT DIKE NODAL THERMAL TIMELINES (Aug 31/15 to Aug 31/16)		
	PROJECT No.		PHASE No.	
	DESIGN	TD	28AUG14	SCALE AS SHOWN
	CADD	TD	28AUG14	REV.
	CHECK	PG	28AUG14	FIGURE 56
REVIEW				

VD-TH3 (71-1)

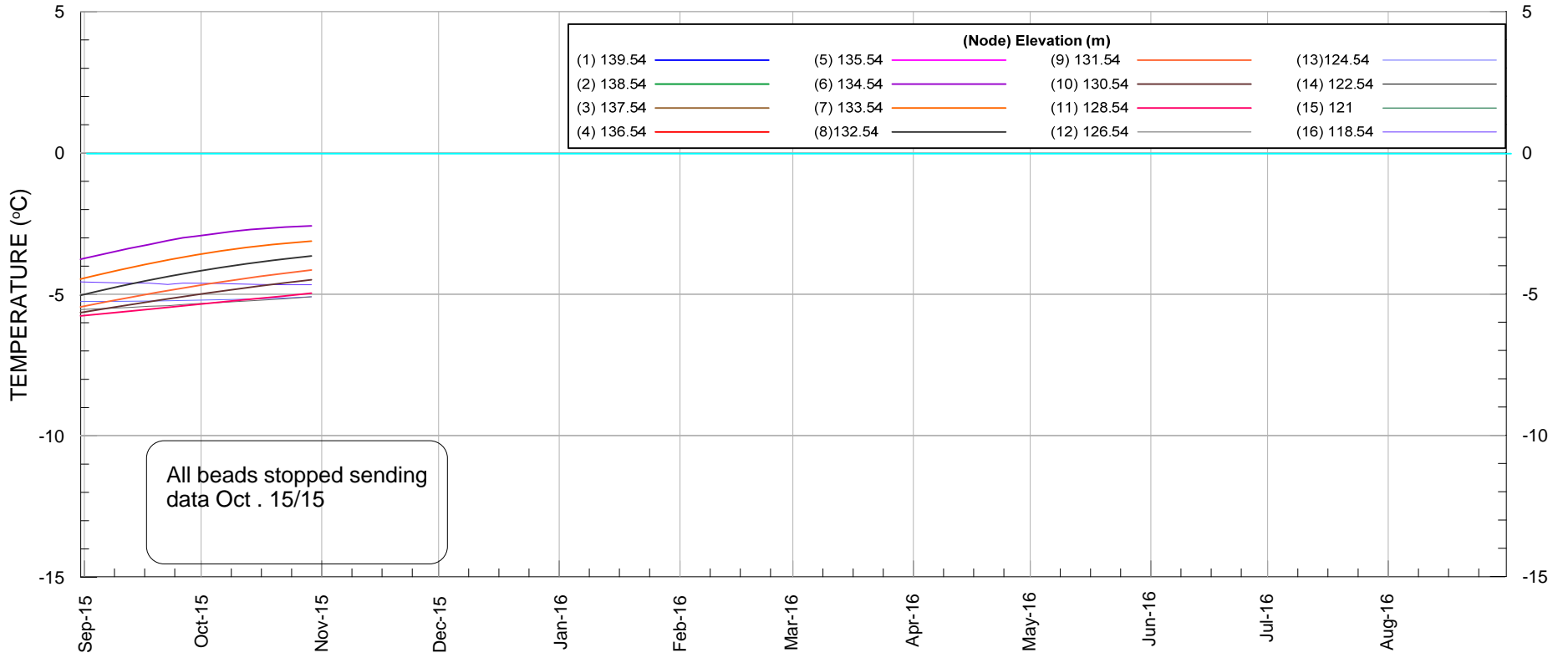

VD-TH5 (71-2) - Installed on slope of the liner

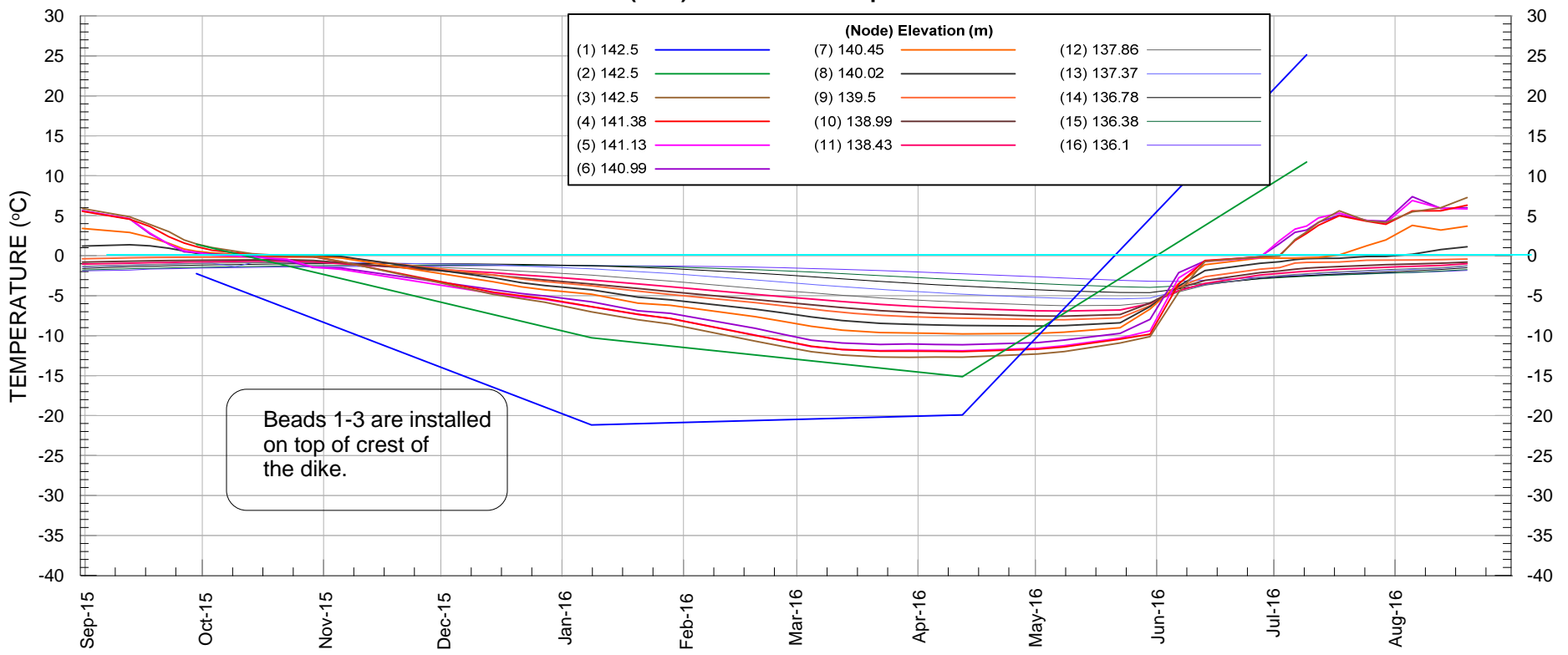

VD-TH6 (94-2)

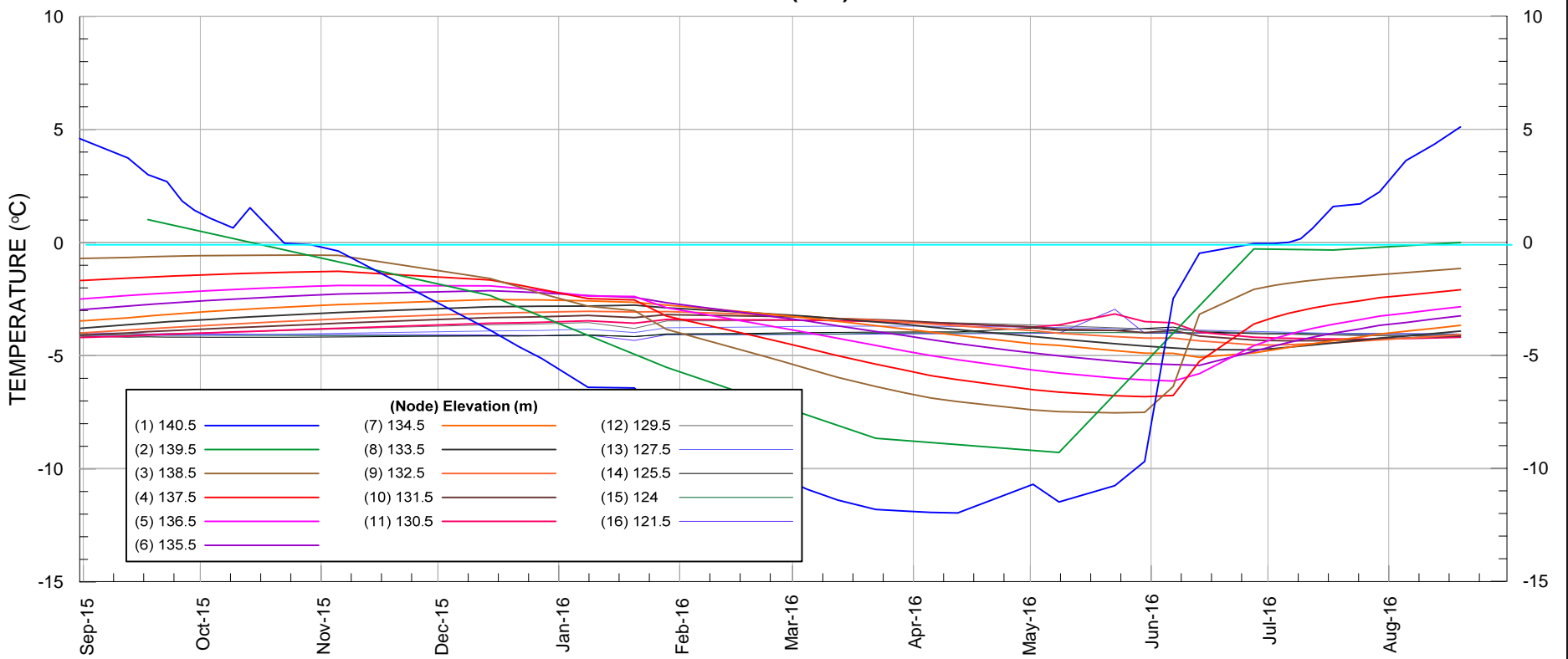

PROJECT		AGNICO EAGLE MINES LIMITED MEADOWBANK GOLD PROJECT NUNAVUT		
TITLE		VAULT DIKE NODAL THERMAL TIMELINES (Aug 31/15 to Aug 31/16)		
	PROJECT No.		PHASE No.	
	DESIGN	TD	28AUG14	SCALE AS SHOWN
	CADD	TD	28AUG14	REV.
	CHECK	PG	28AUG14	FIGURE 55
REVIEW				



APPENDIX C2

TSF South Cell Instrumentation Data



AGNICO EAGLE

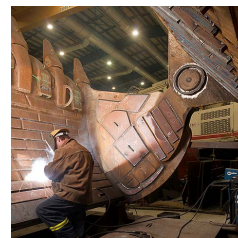
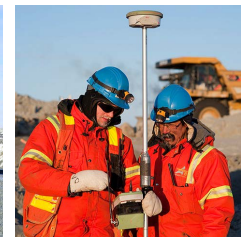

MDRB # 19

CD INSTRUMENTATION REVIEW

INSTRUMENTATIONS – CENTRAL DIKE

A total of 47 piezometers and 15 thermistors installed

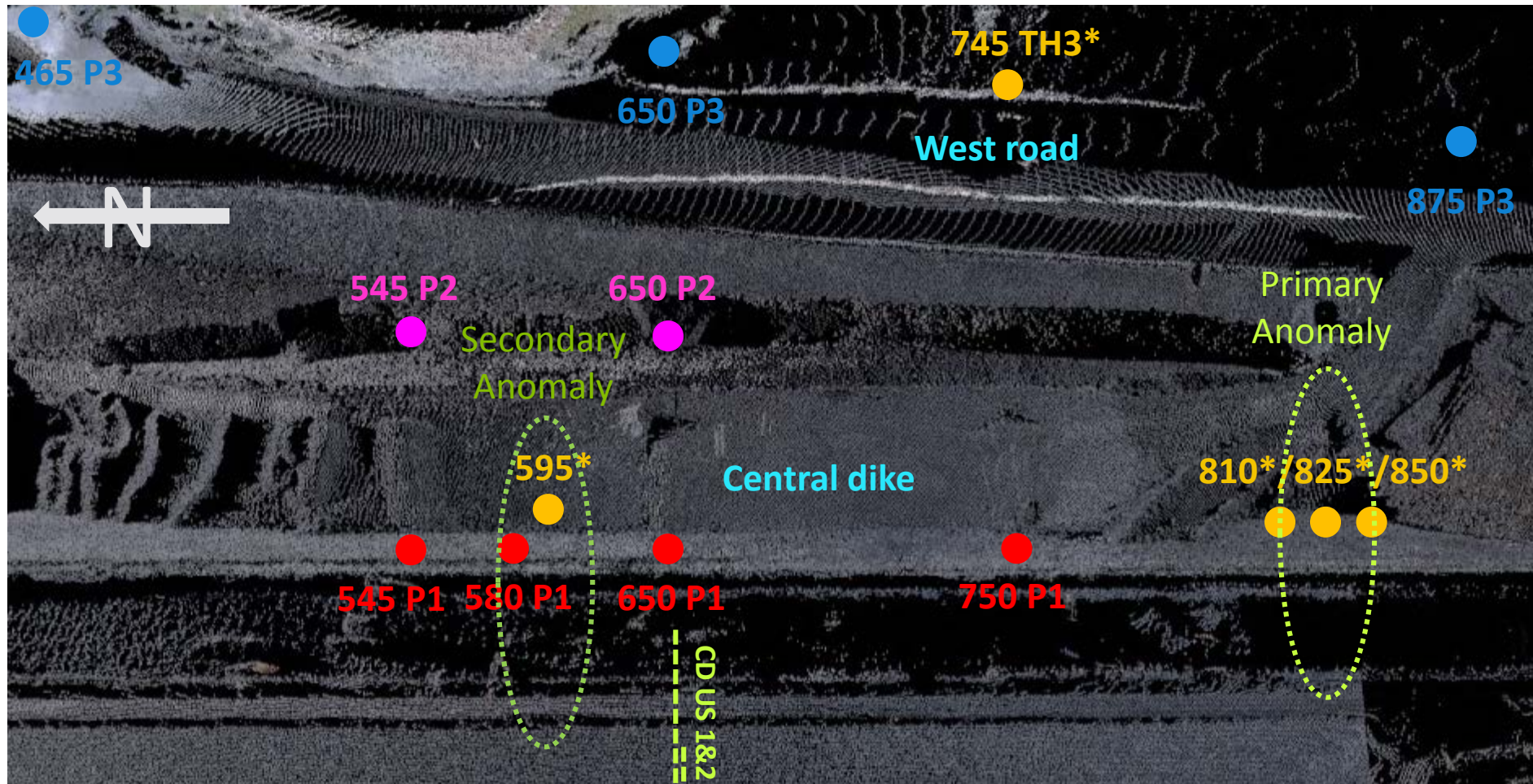

INSTRUMENTATION RESULTS

Piezometers 465 P3

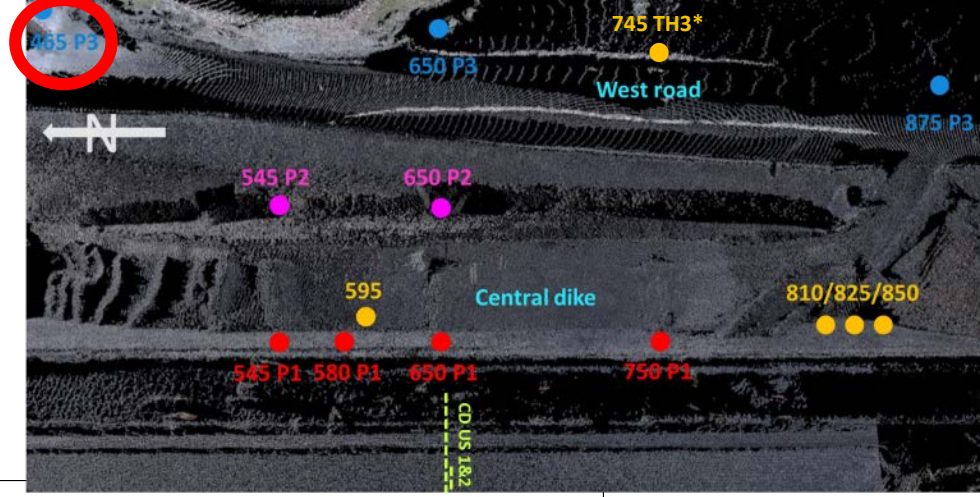

465-P3 Hole - Piezometrics Elevation and Attenuation Pond Elevation vs time

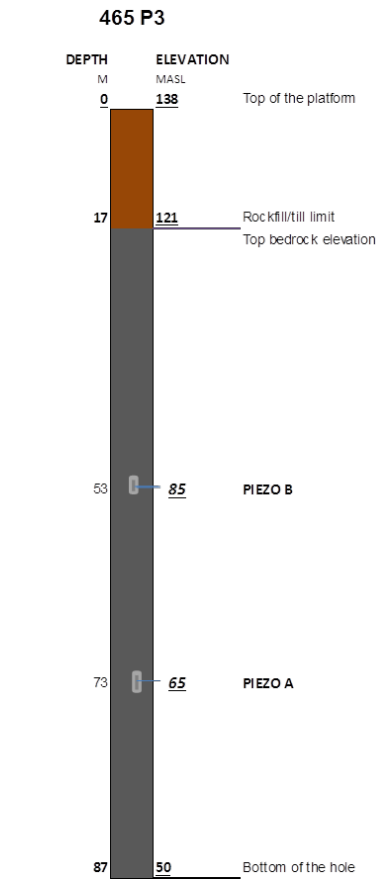
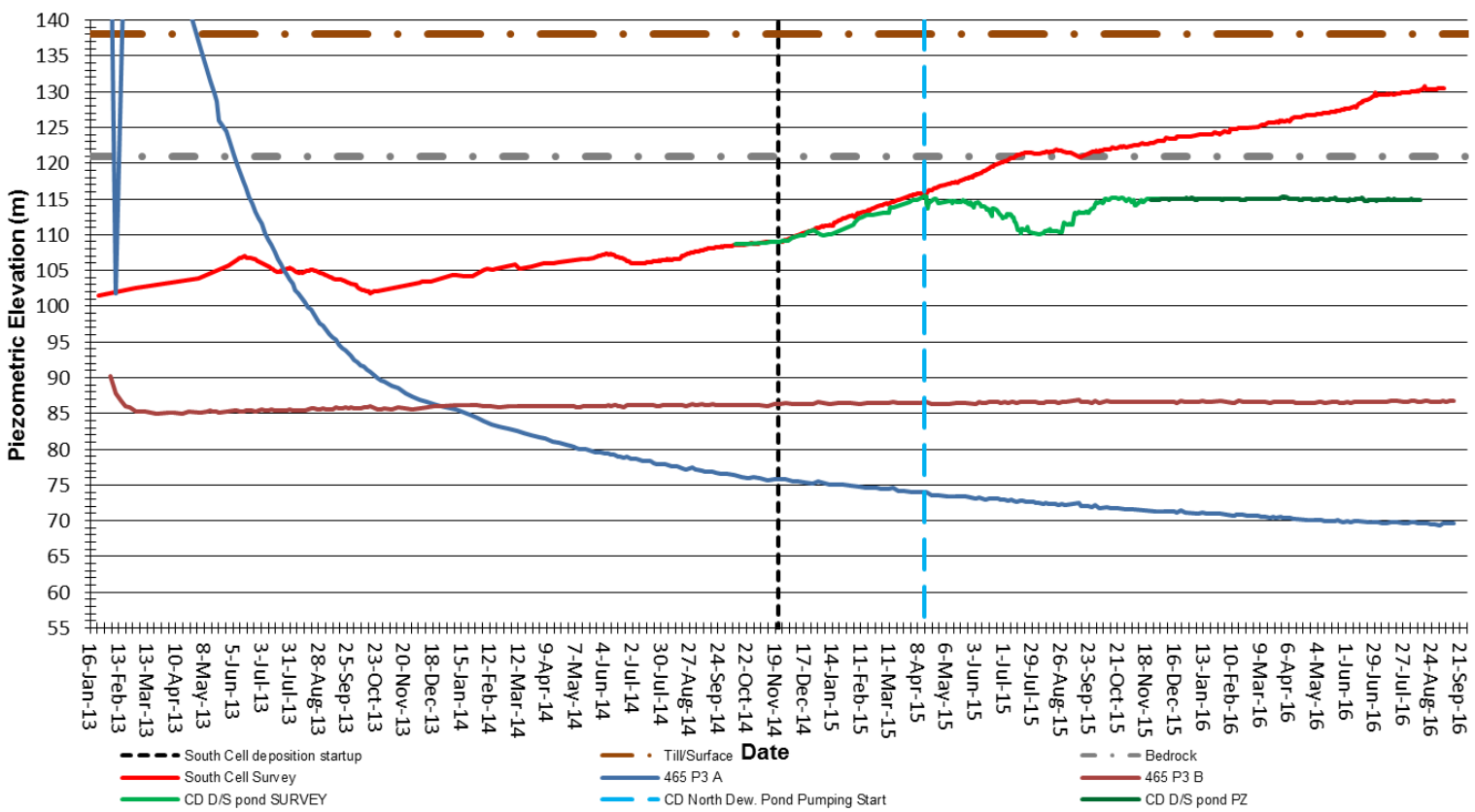

INSTRUMENTATION RESULTS

Thermistor 465 P3

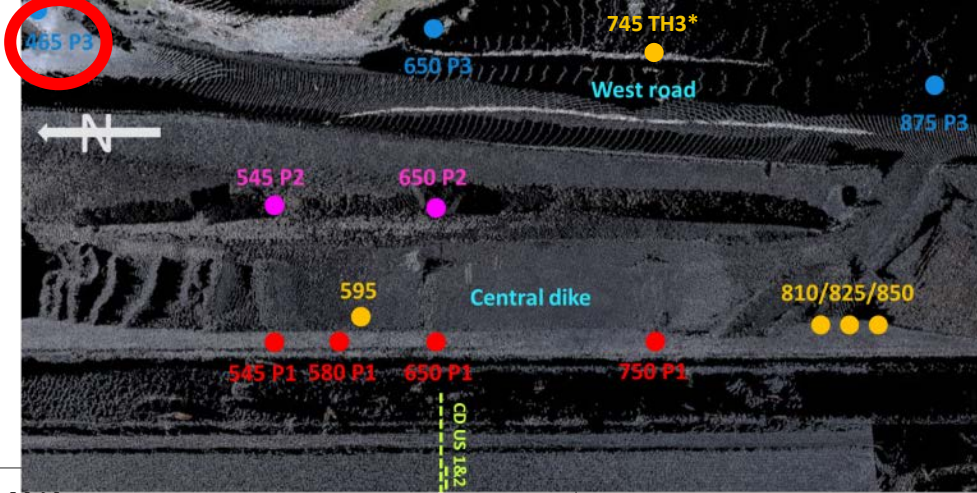

465-P3 Central Dike - Bead Temperature vs. Elevation - 2016

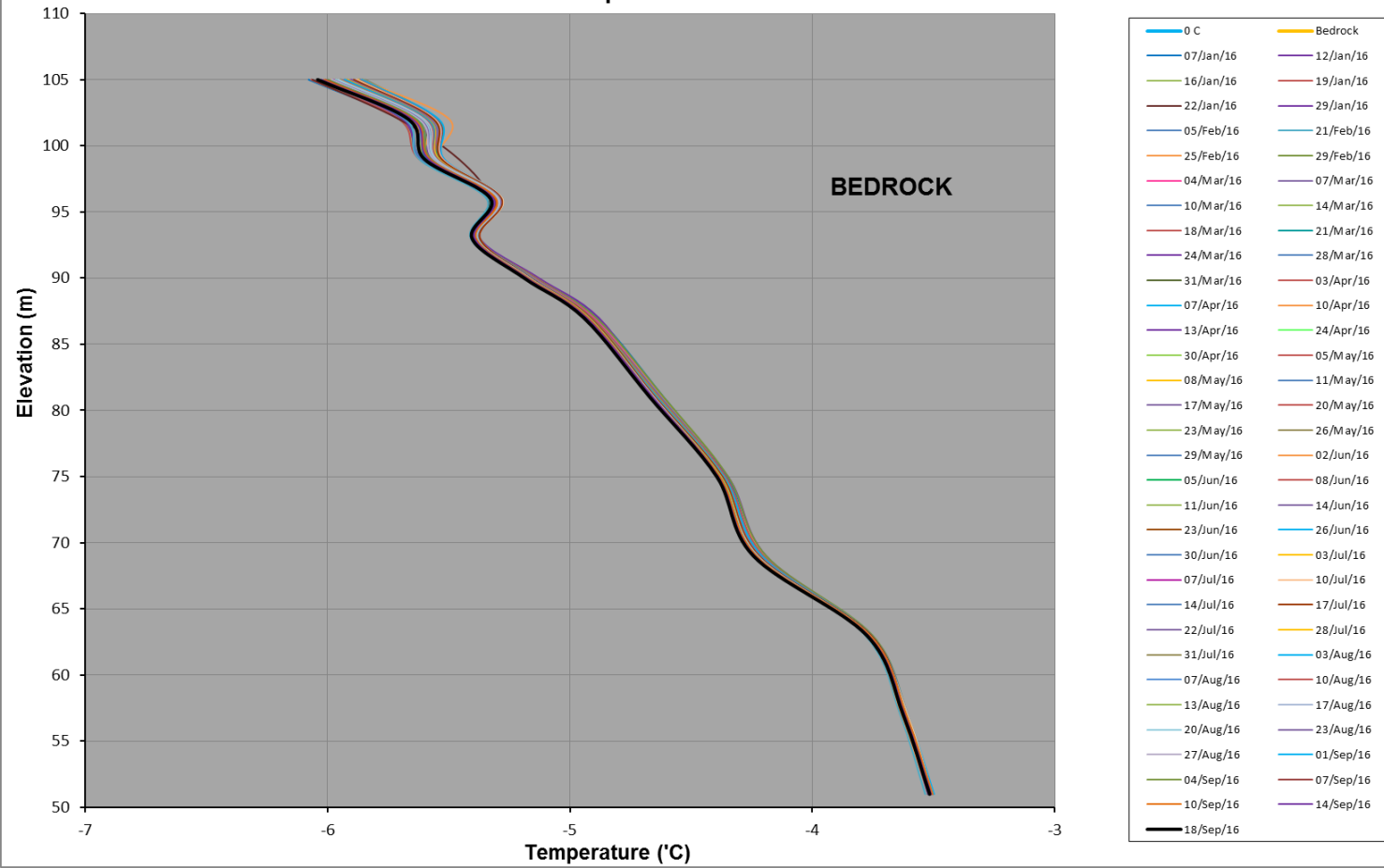

INSTRUMENTATION RESULTS

Piezometers 545 P2

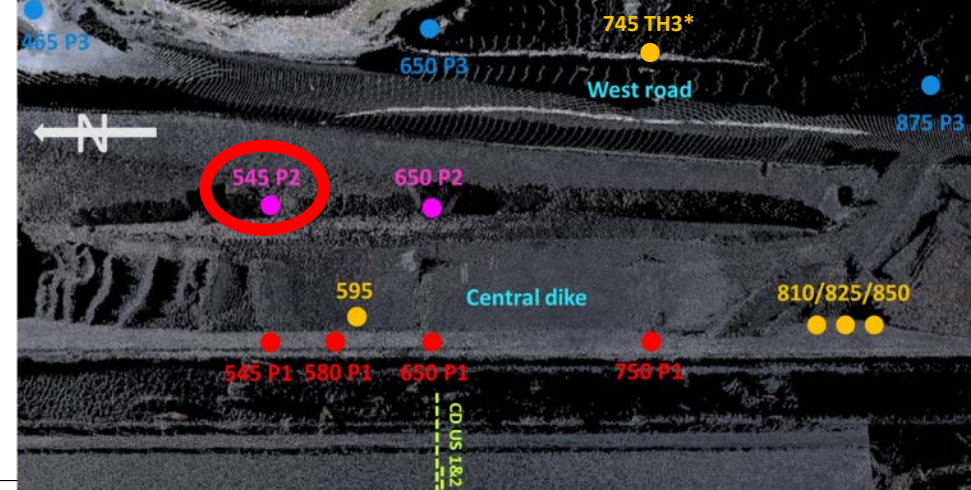

545-P2 Hole - Piezometrics Elevation and Attenuation Pond Elevation vs Time

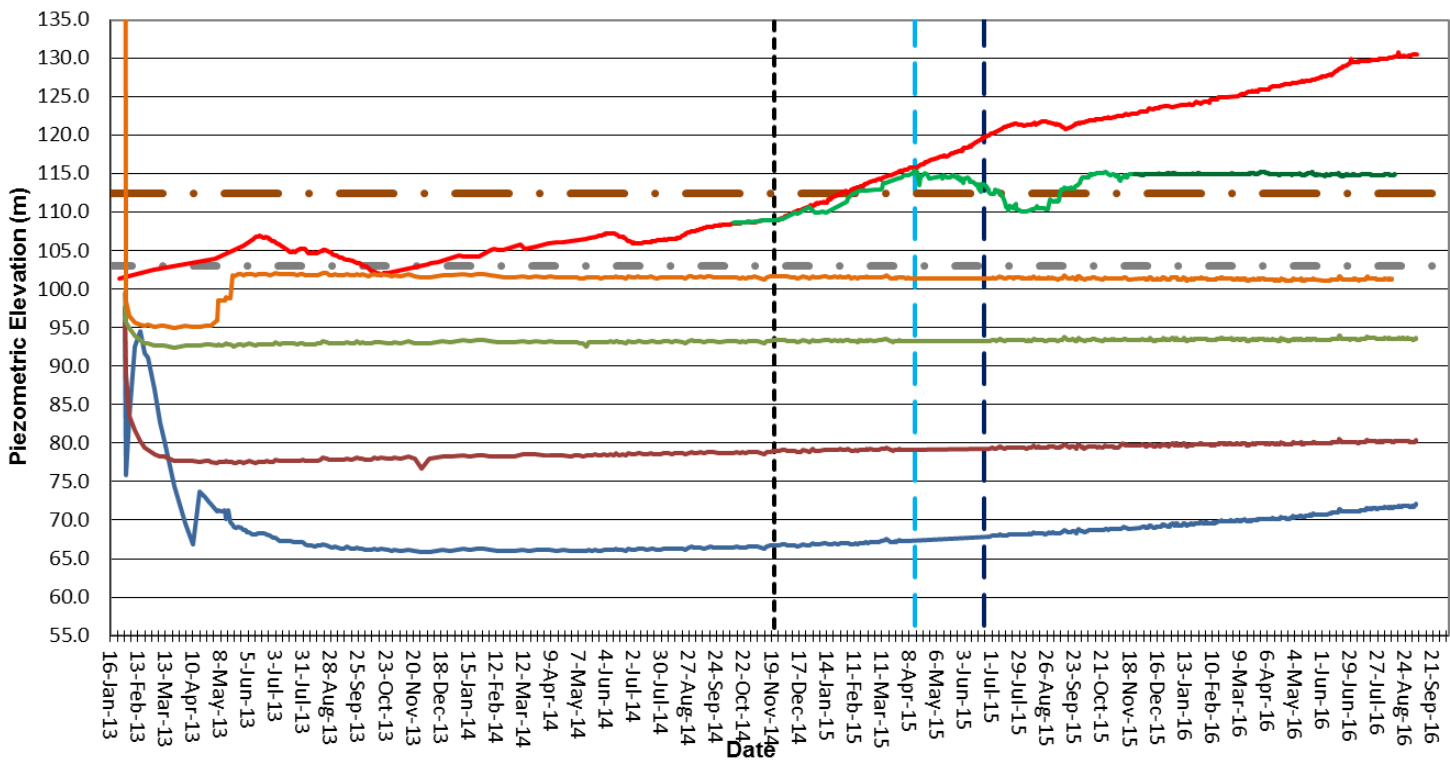

- South Cell deposition startup
- - - Bedrock
- 545 P2 C
- 545 P2 D
- CD North Dew. Pond Pumping Start
- South Cell Survey
- CD D/S pond SURVEY
- CD D/S Toe Pumping Start
- 545 P2 A
- CD D/S pond SURVEY
- Till Surface
- 545 P2 B
- CD D/S pond PZ

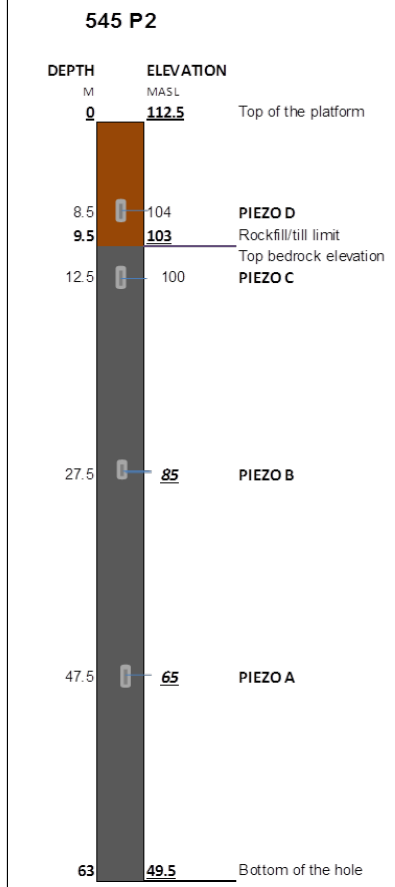

INSTRUMENTATION RESULTS

Piezometers 545 P1

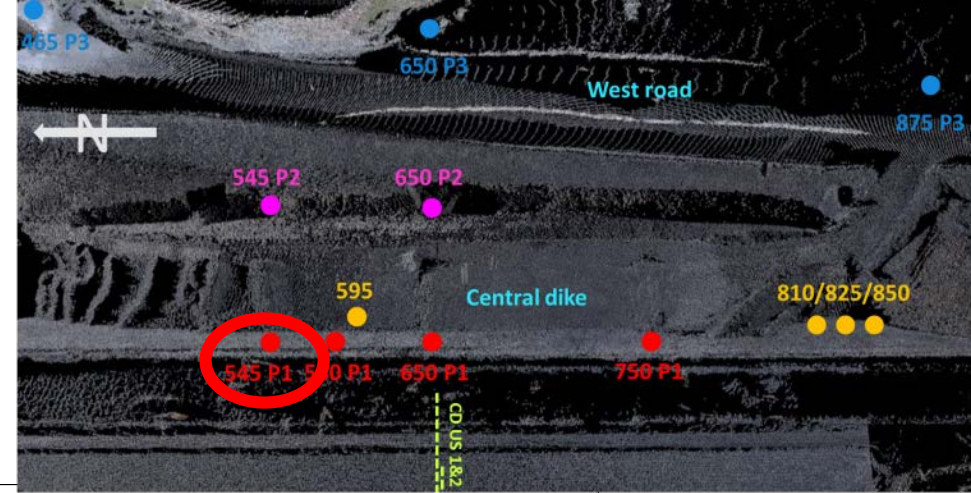

545-P1 Hole - Piezometrics Elevation and Attenuation Pond Elevation vs Time

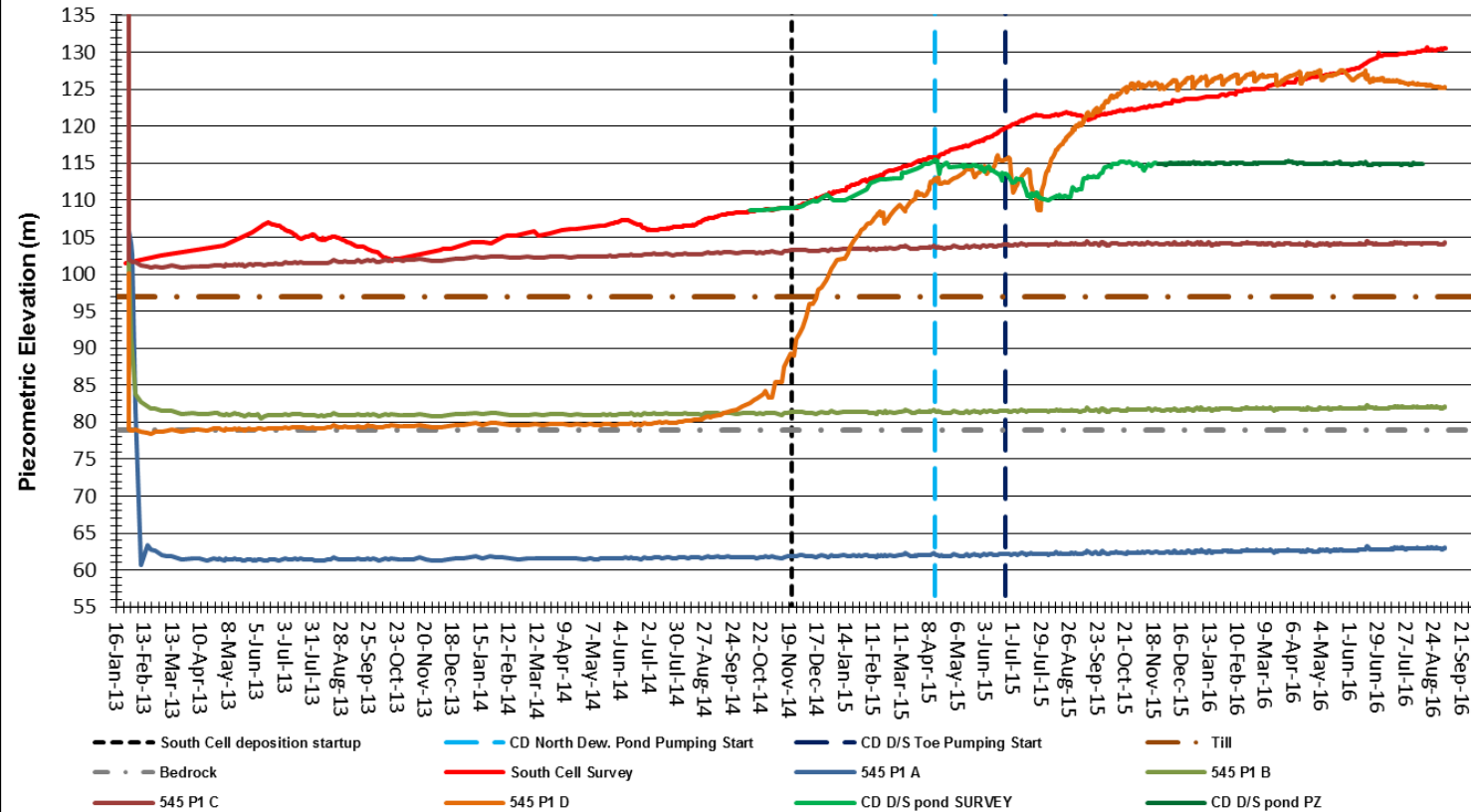

545 P1

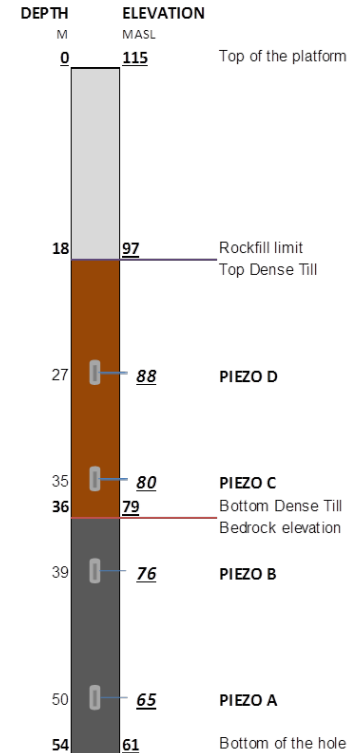

INSTRUMENTATION RESULTS

Thermistor 545 Section

MAY 2016

Grapher

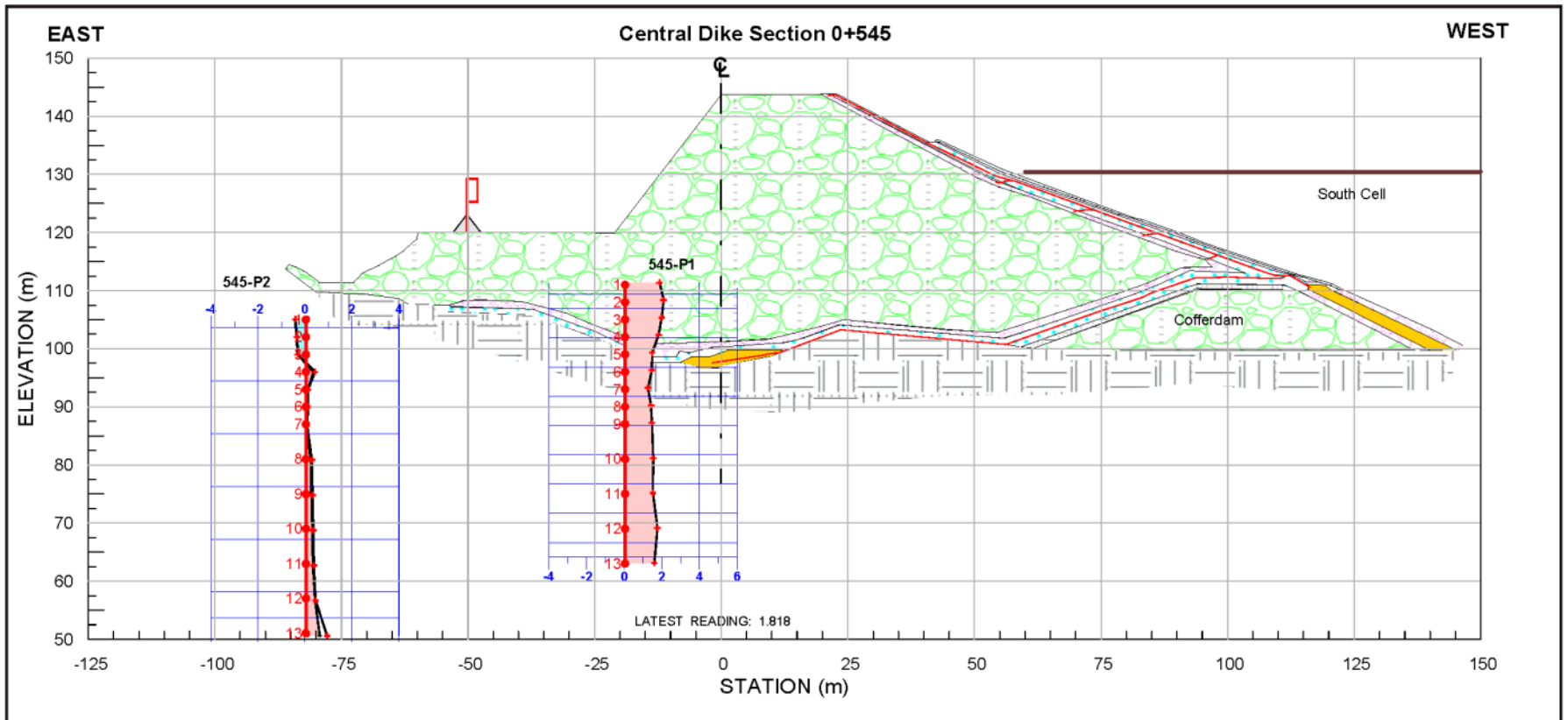
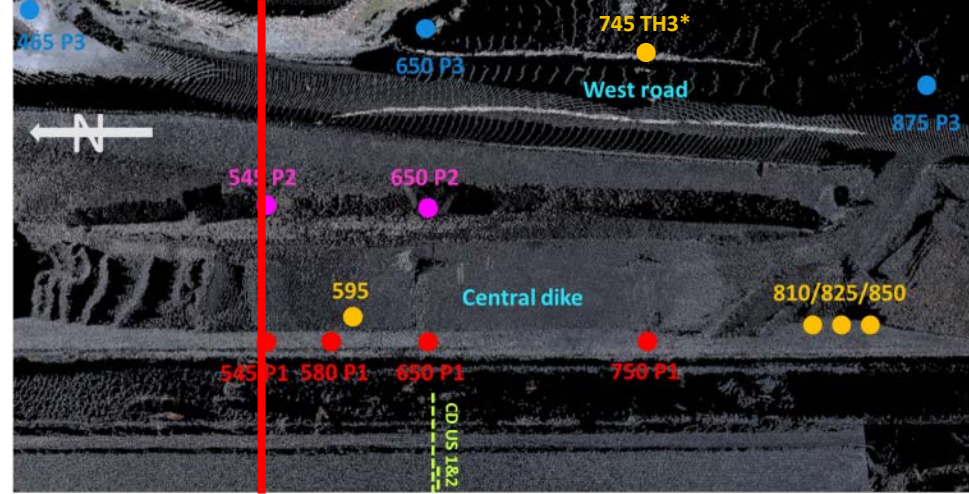

INSTRUMENTATION RESULTS

Thermistor 545 Section

JUNE 2016

Grapher

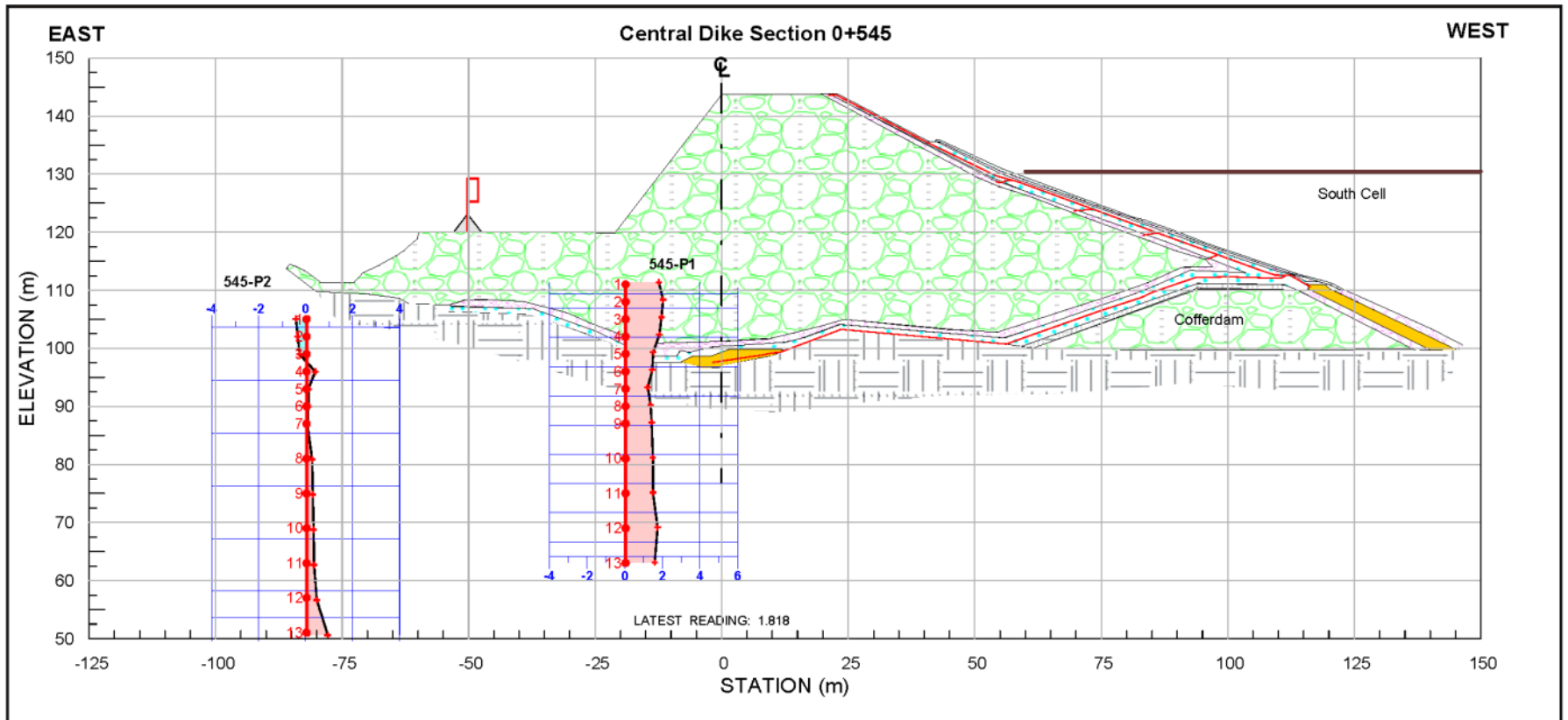
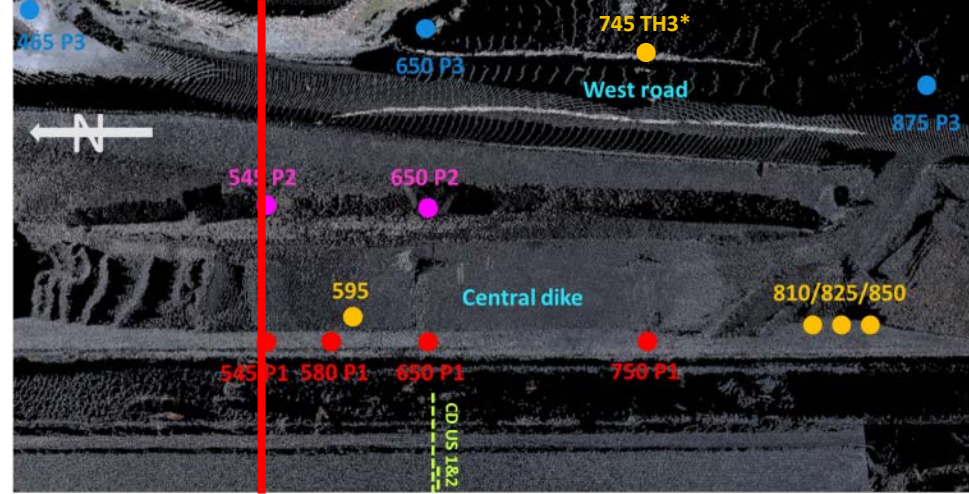

INSTRUMENTATION RESULTS

Thermistor 545 Section

JULY 2016

Grapher

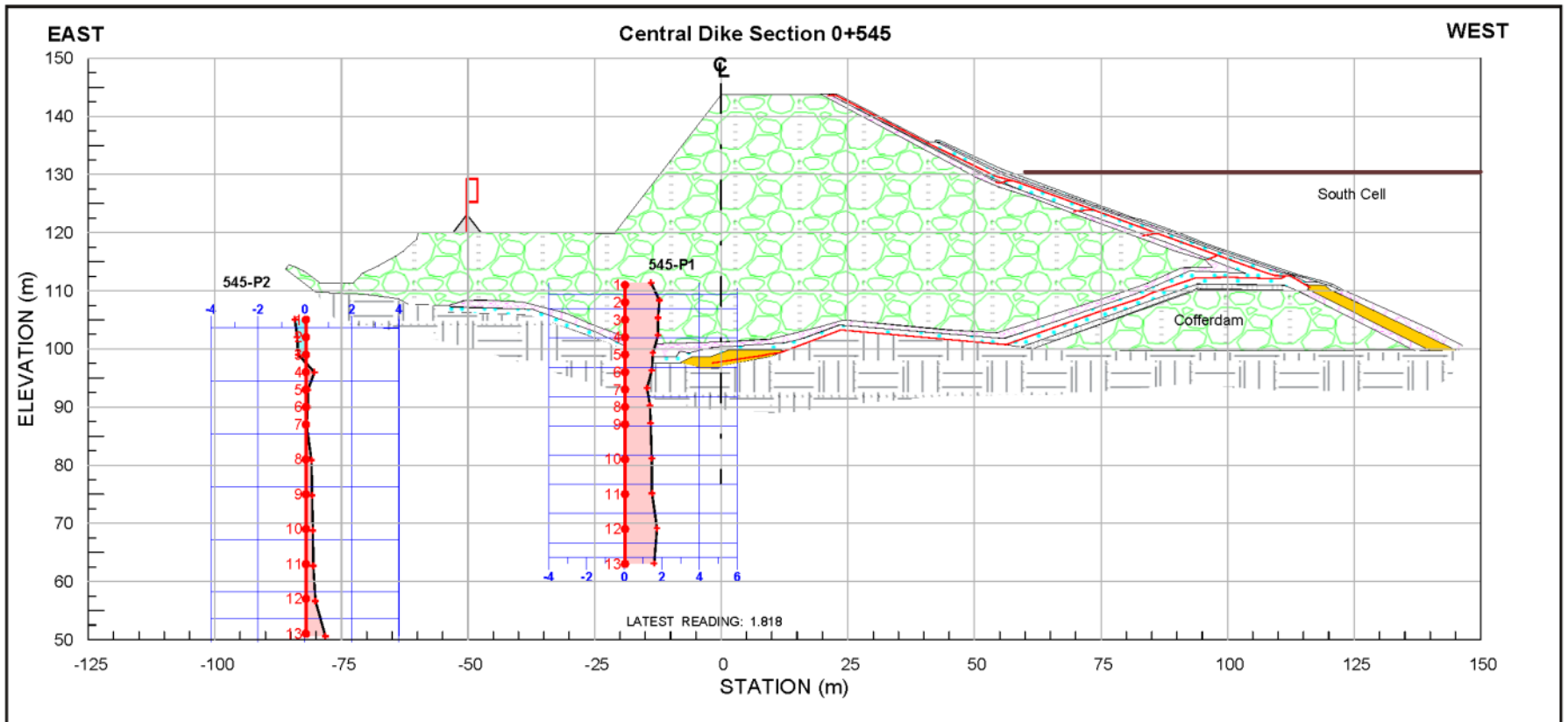
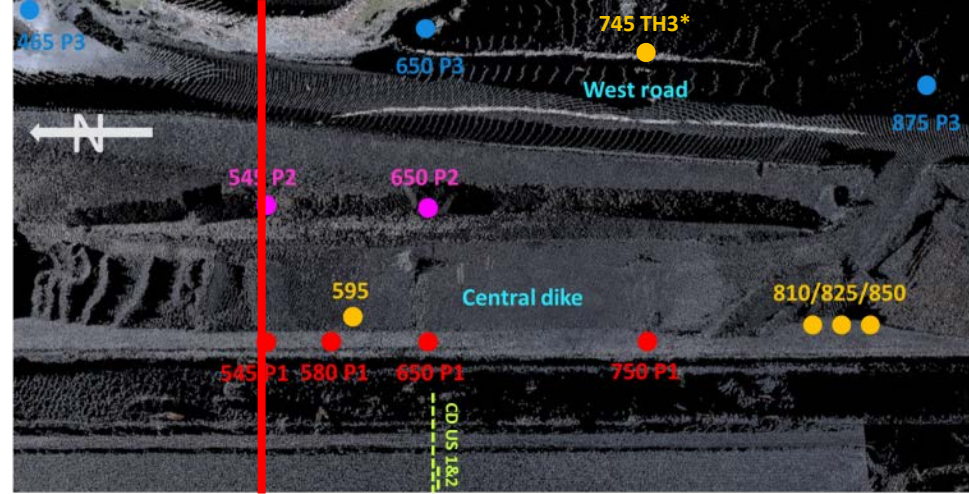

INSTRUMENTATION RESULTS

Thermistor 545 Section

AUGUST 2016

Grapher

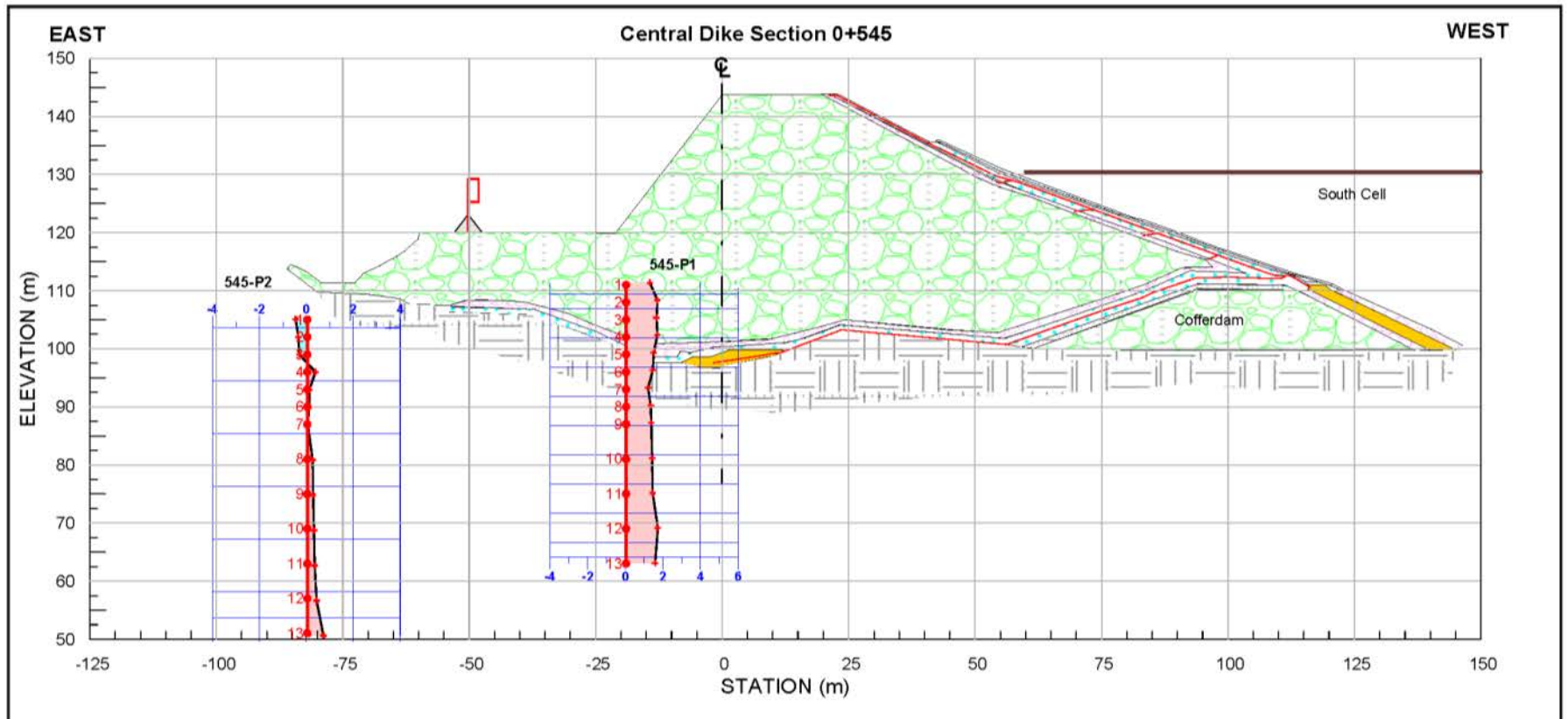
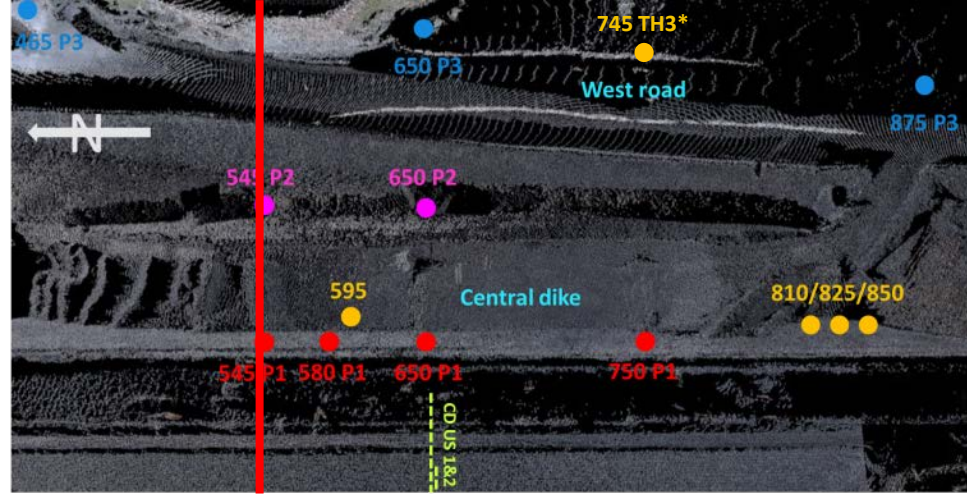

INSTRUMENTATION RESULTS

Thermistor 545 Section

FULL YEAR 545 P1



AGNICO EAGLE

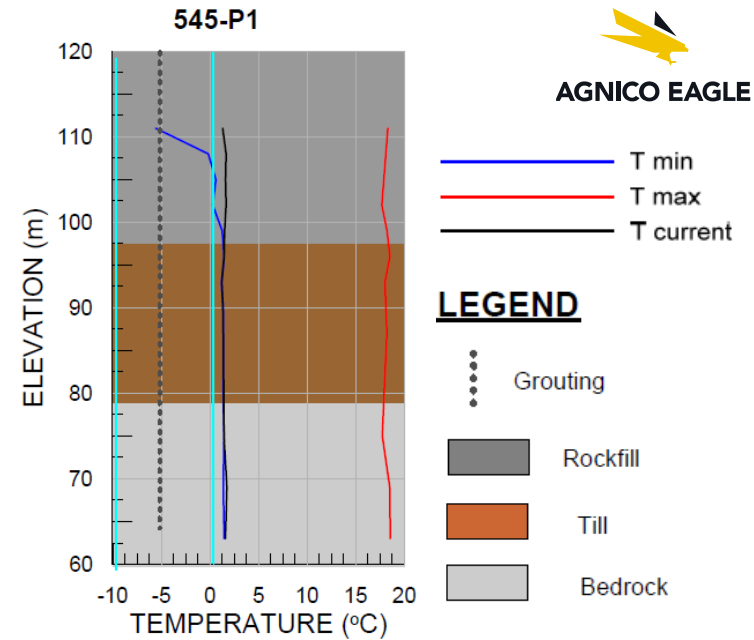

Temperature - 545-P1

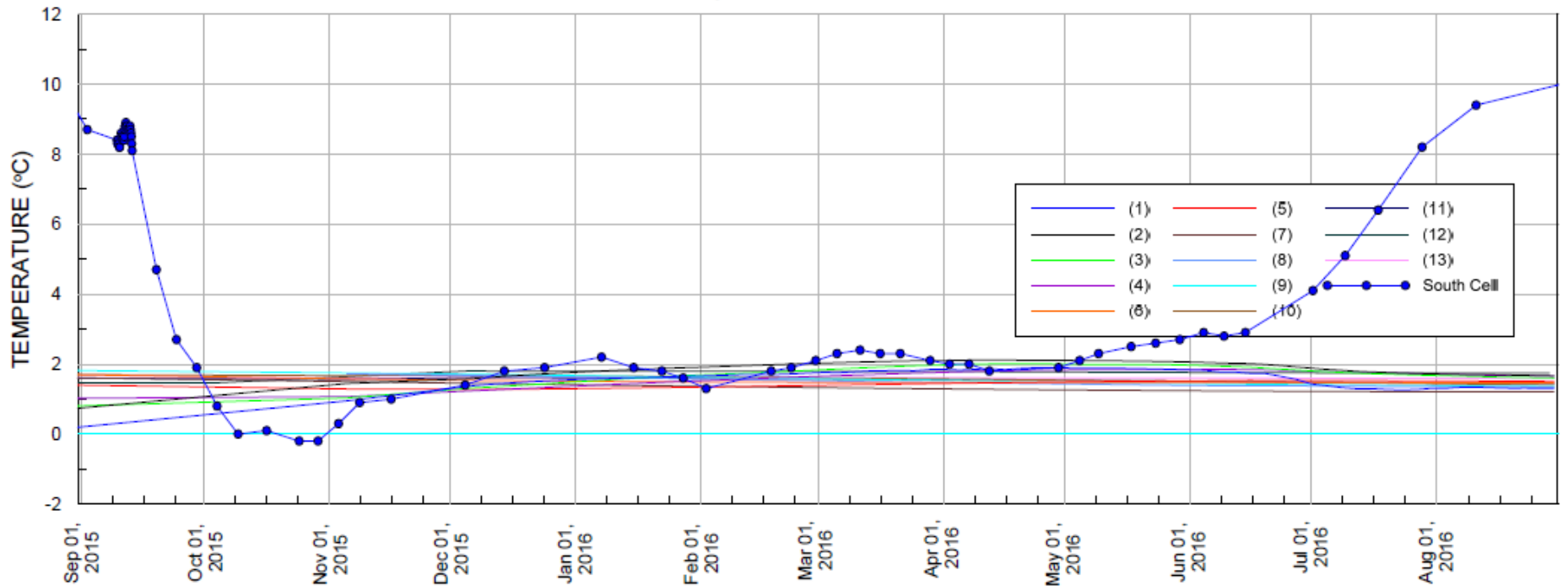

INSTRUMENTATION RESULTS

Thermistor 545 Section

FULL YEAR 545 P2



AGNICO EAGLE

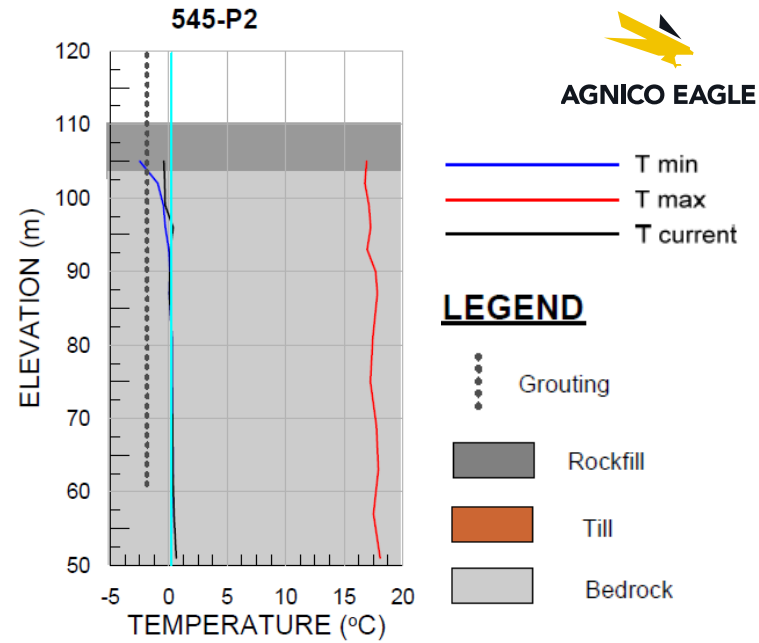

Temperature - 545 - P2

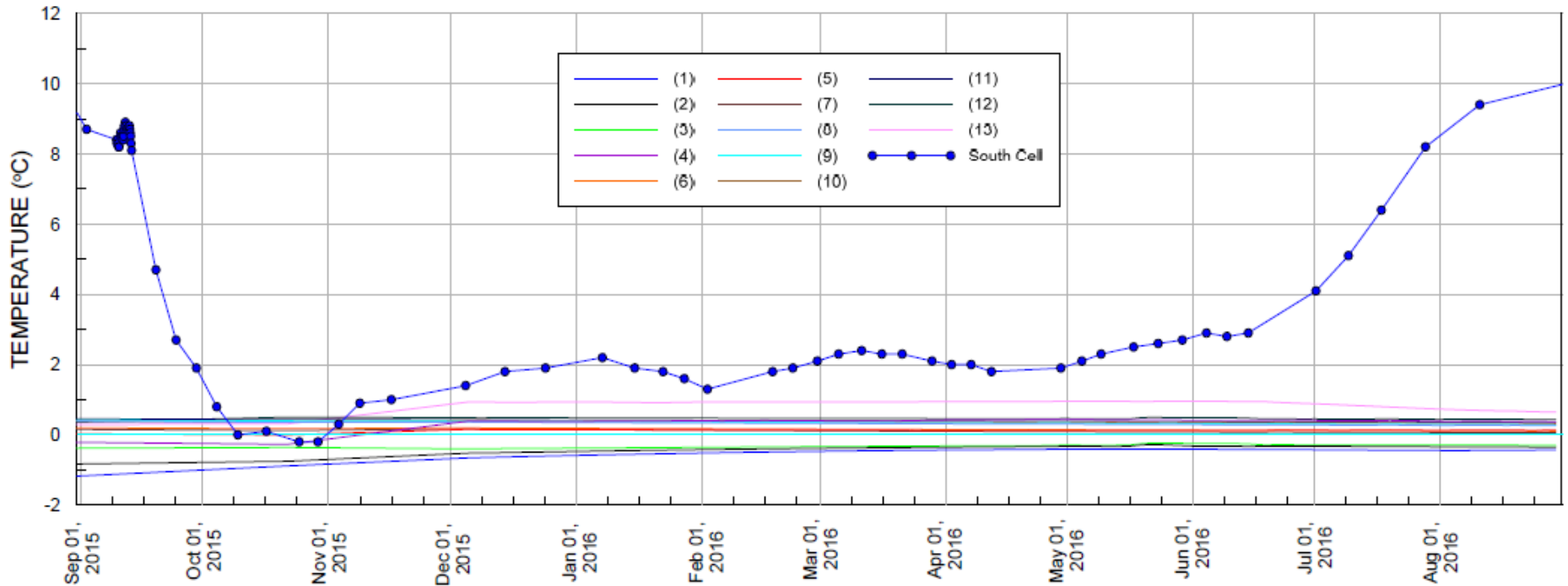

INSTRUMENTATION RESULTS

Piezometers 580 P1

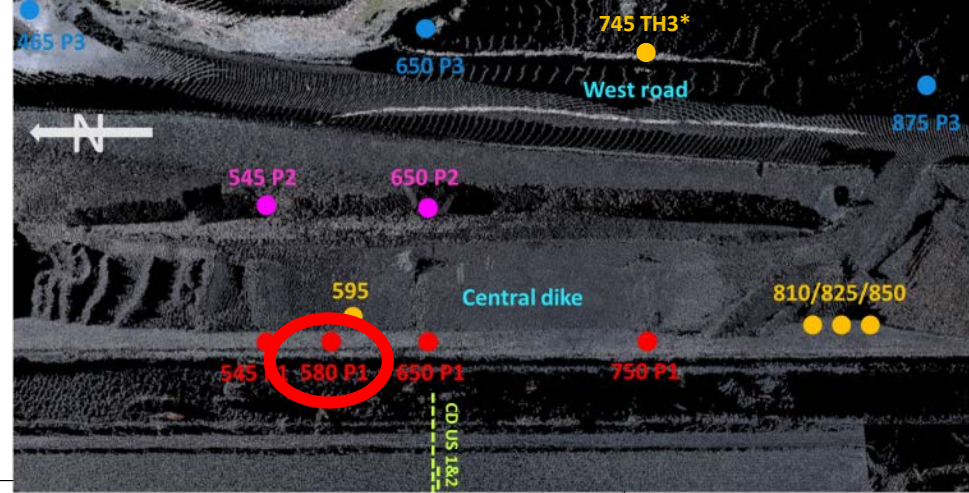

580-P1 Hole - Piezometrics Elevation and Attenuation Pond Elevation vs Time

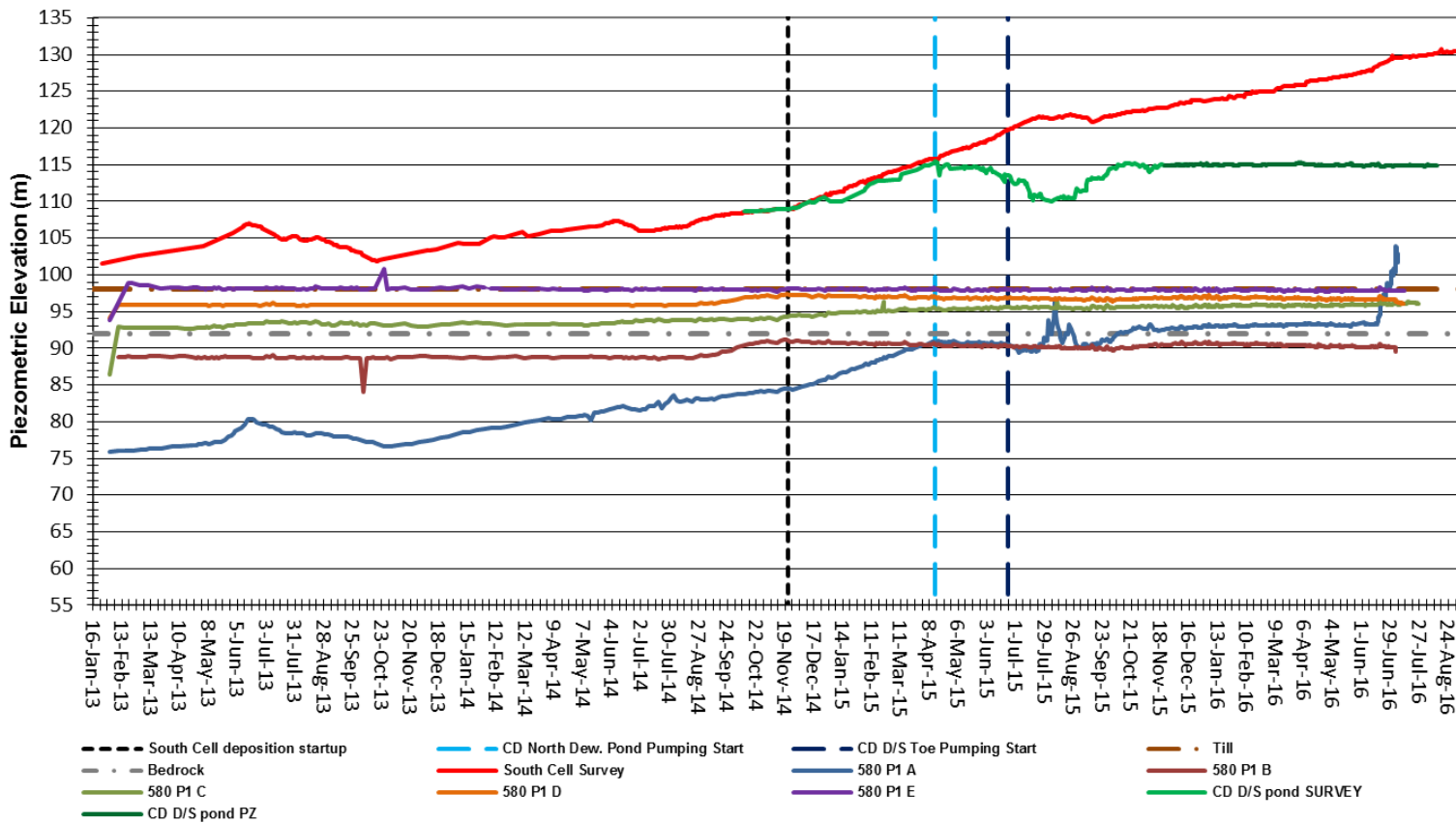

580 P1

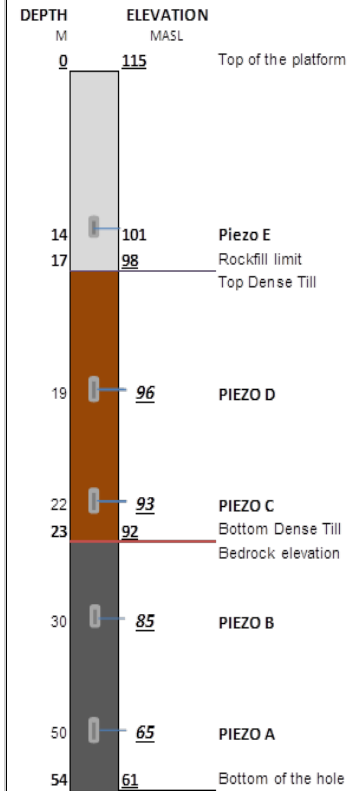

INSTRUMENTATION RESULTS

Thermistor 580 P1

MAY 2016

Grapher

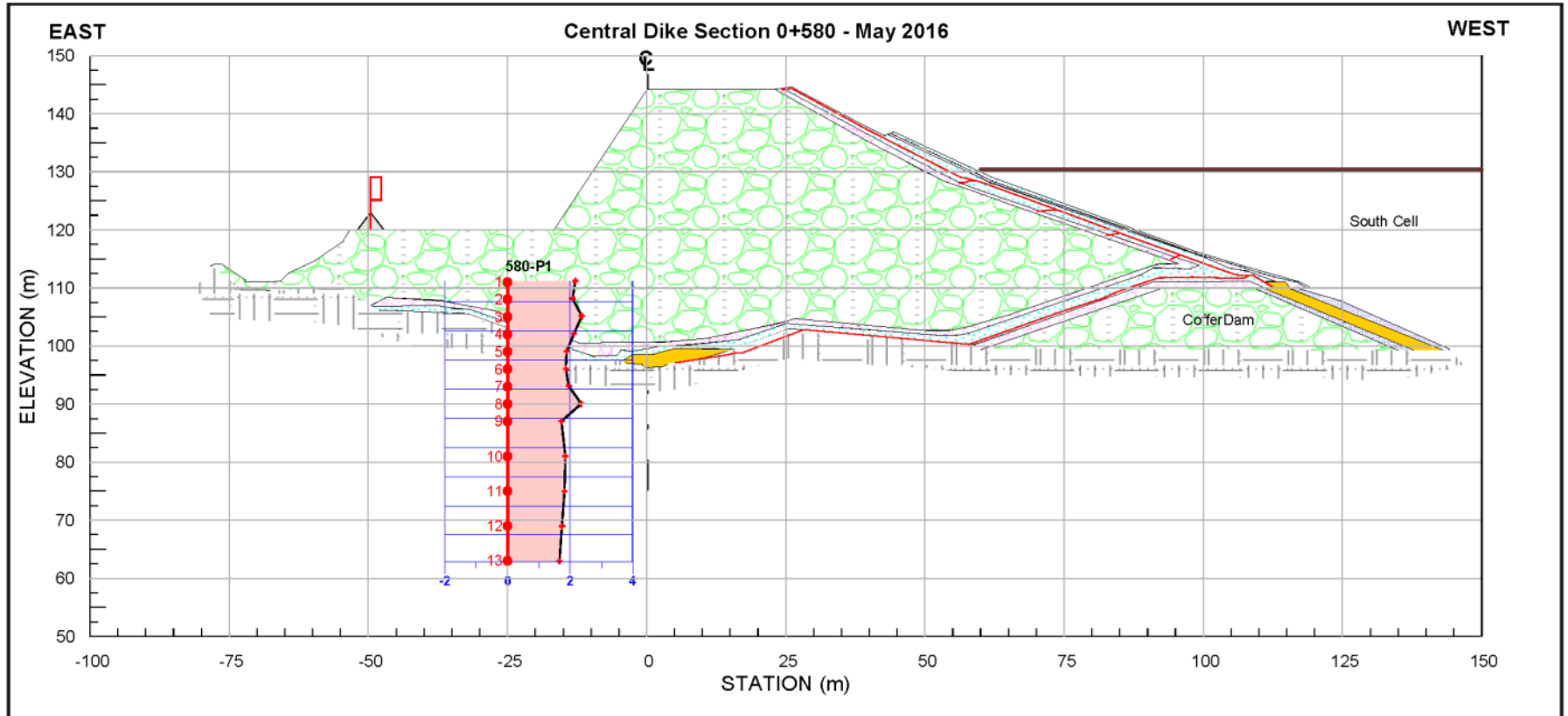
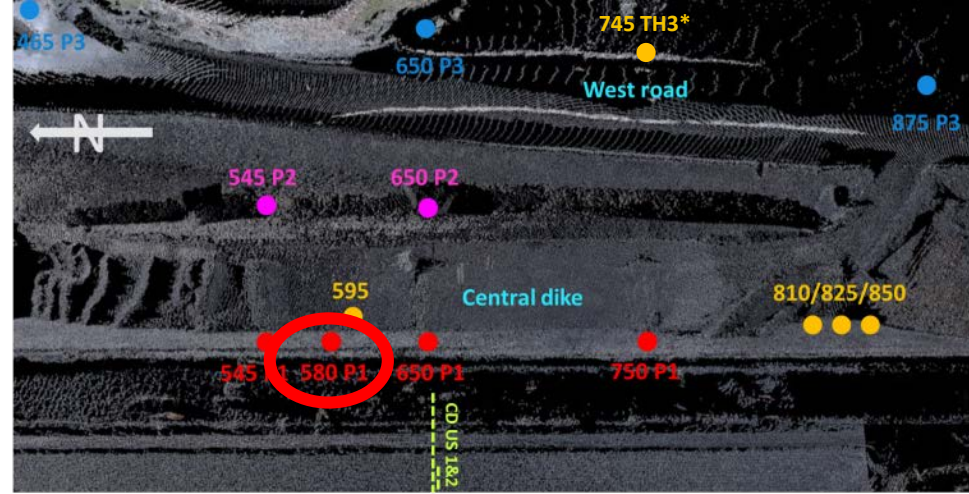

INSTRUMENTATION RESULTS

Thermistor 580 P1

JUNE 2016

Grapher

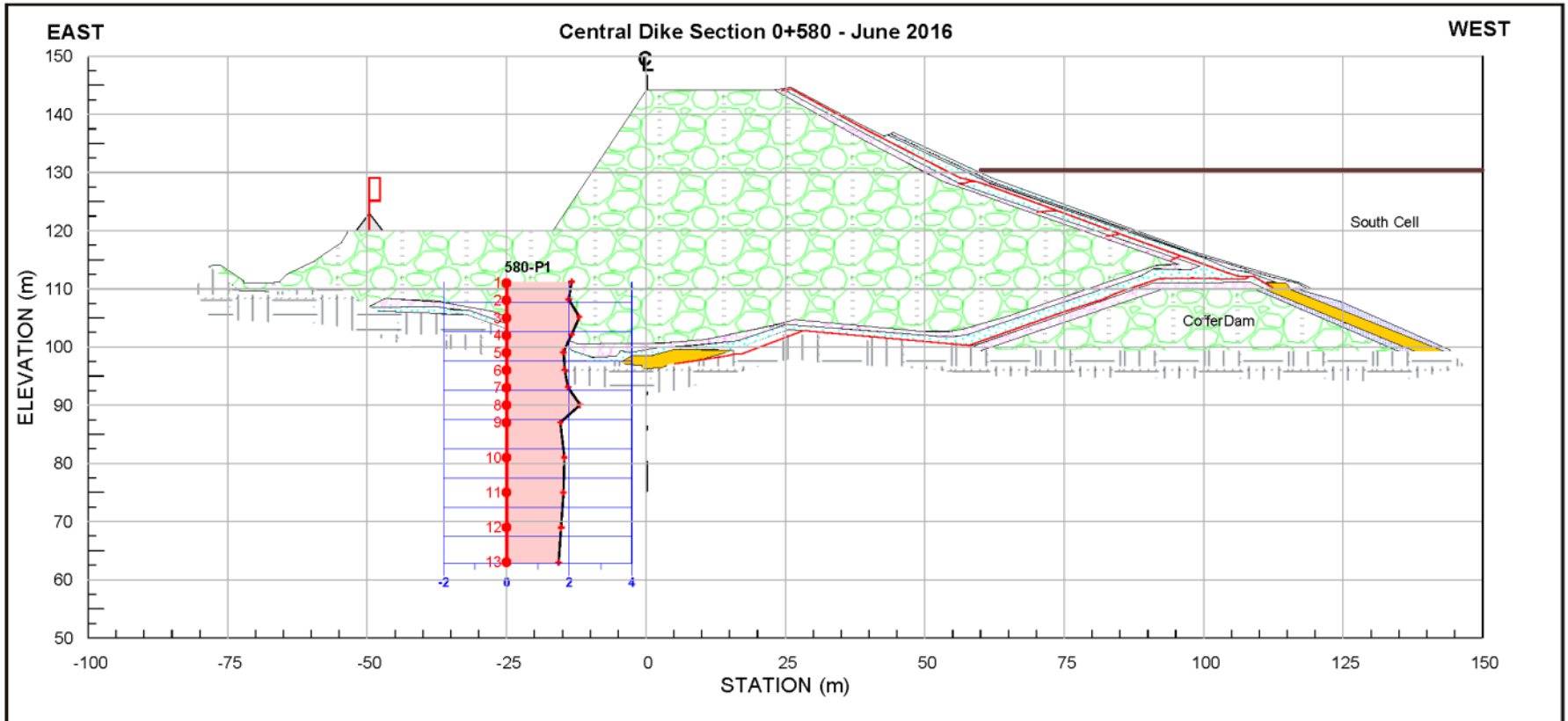
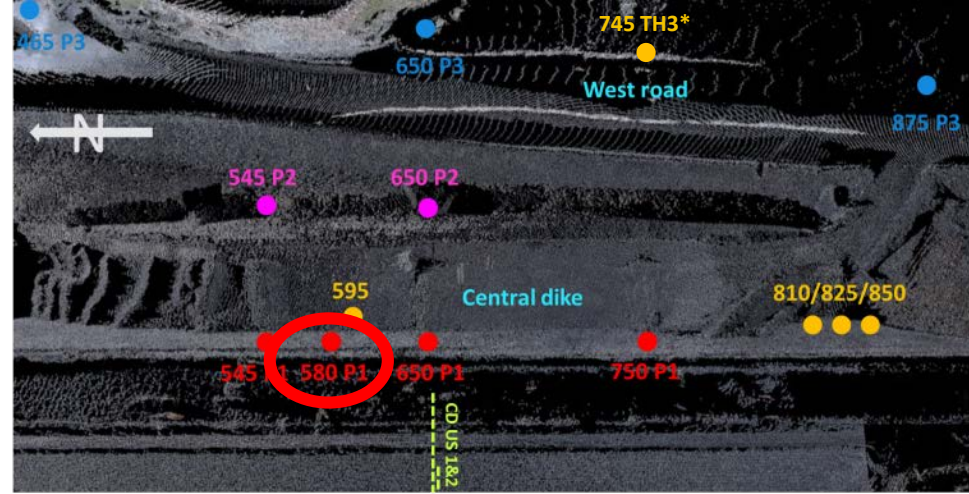

INSTRUMENTATION RESULTS

Thermistor 580 P1

JULY 2016

Grapher

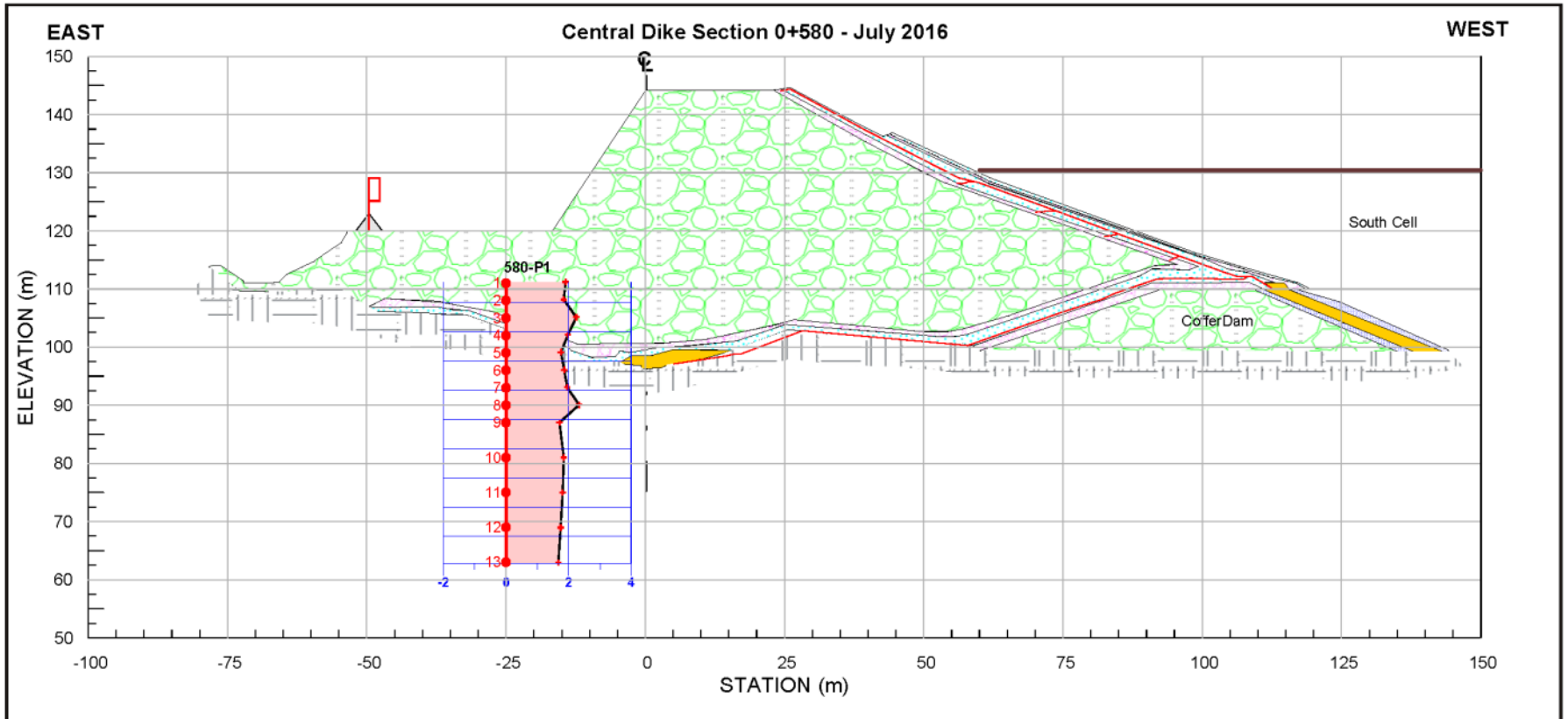
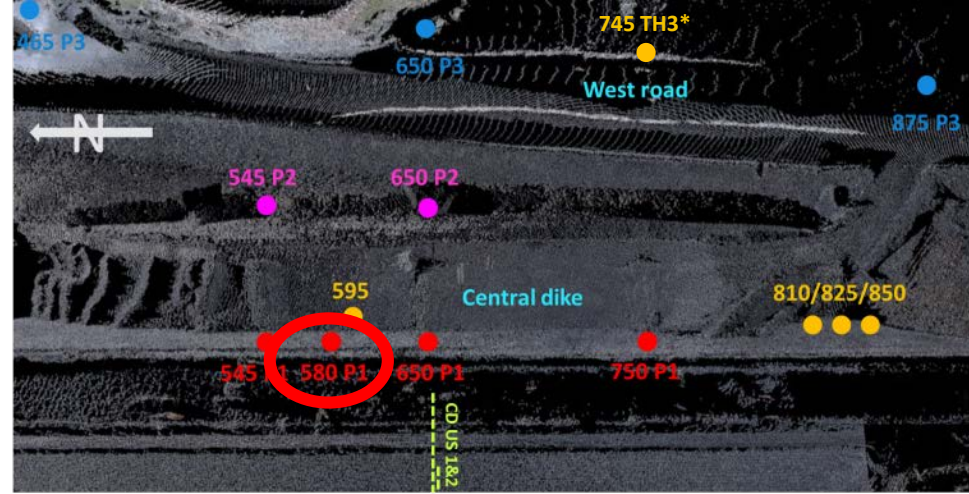

INSTRUMENTATION RESULTS

Thermistor 580 P1

FULL YEAR



AGNICO EAGLE

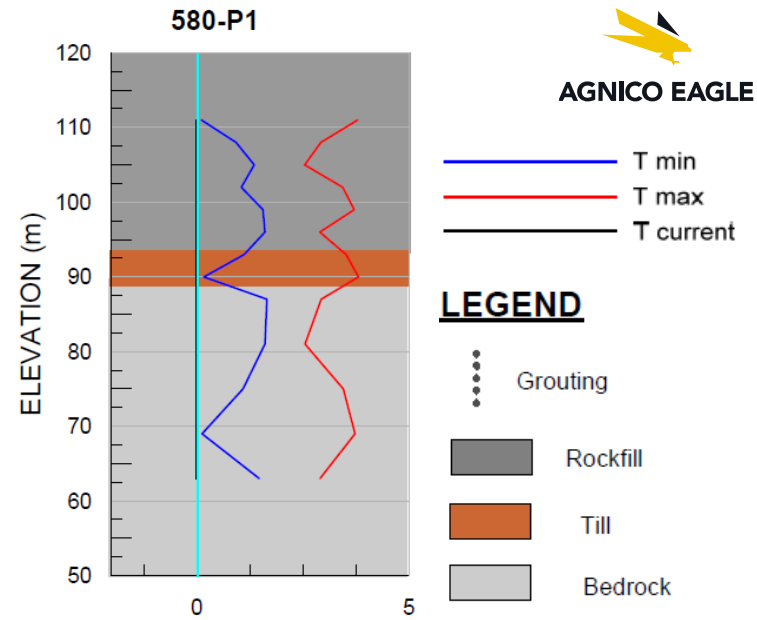

Temperature

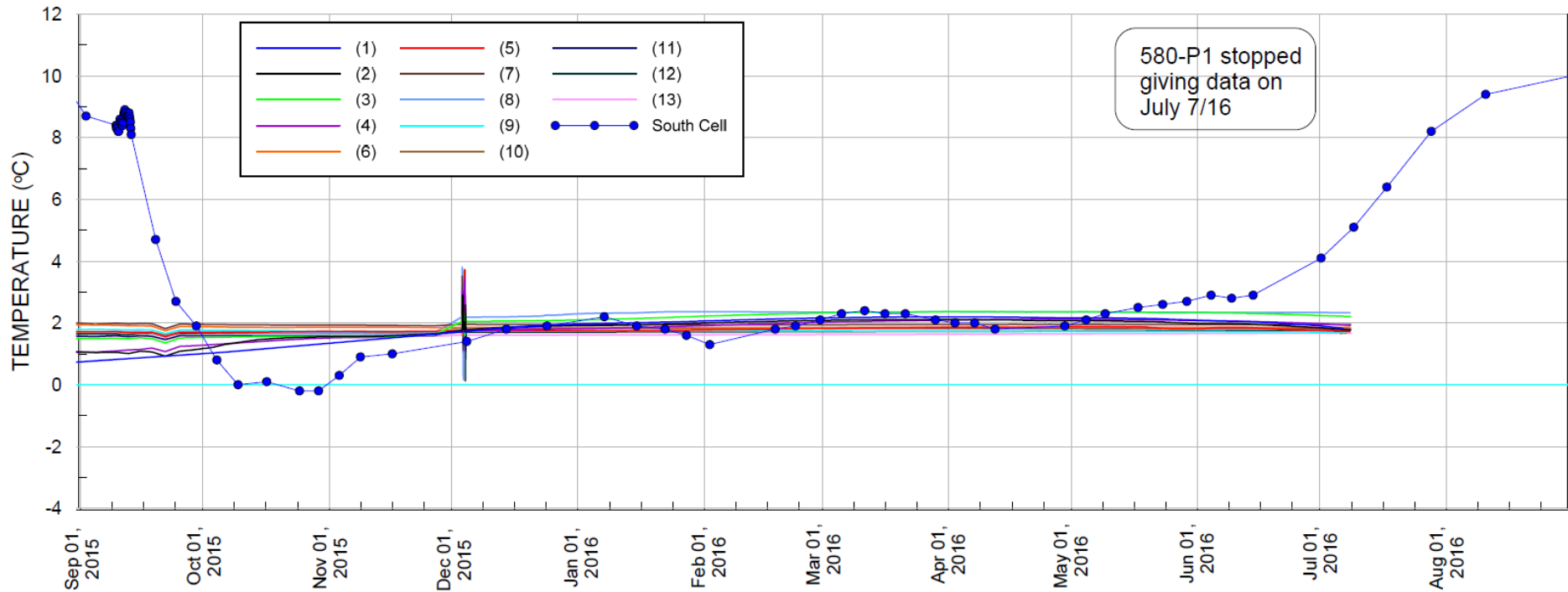

INSTRUMENTATION RESULTS

Piezometers 595*

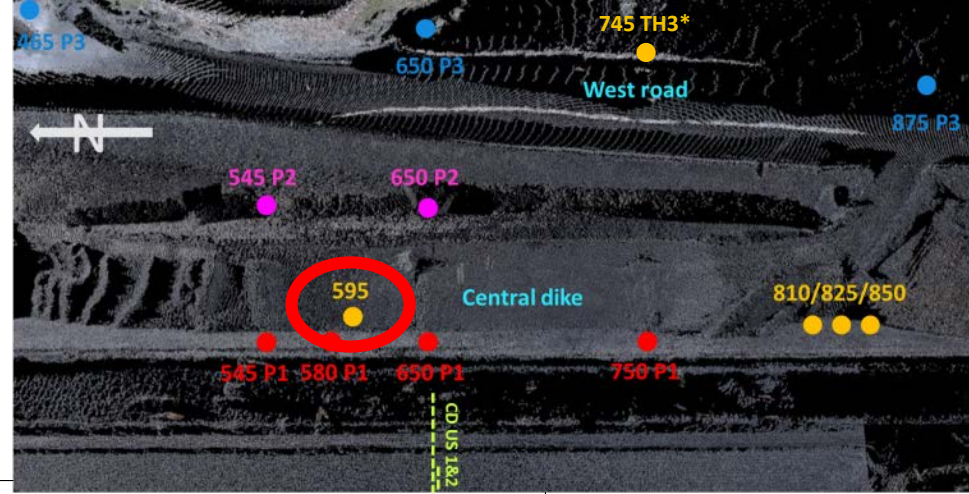

595 Hole - Piezometrics Elevation and Attenuation Pond Elevation vs Time

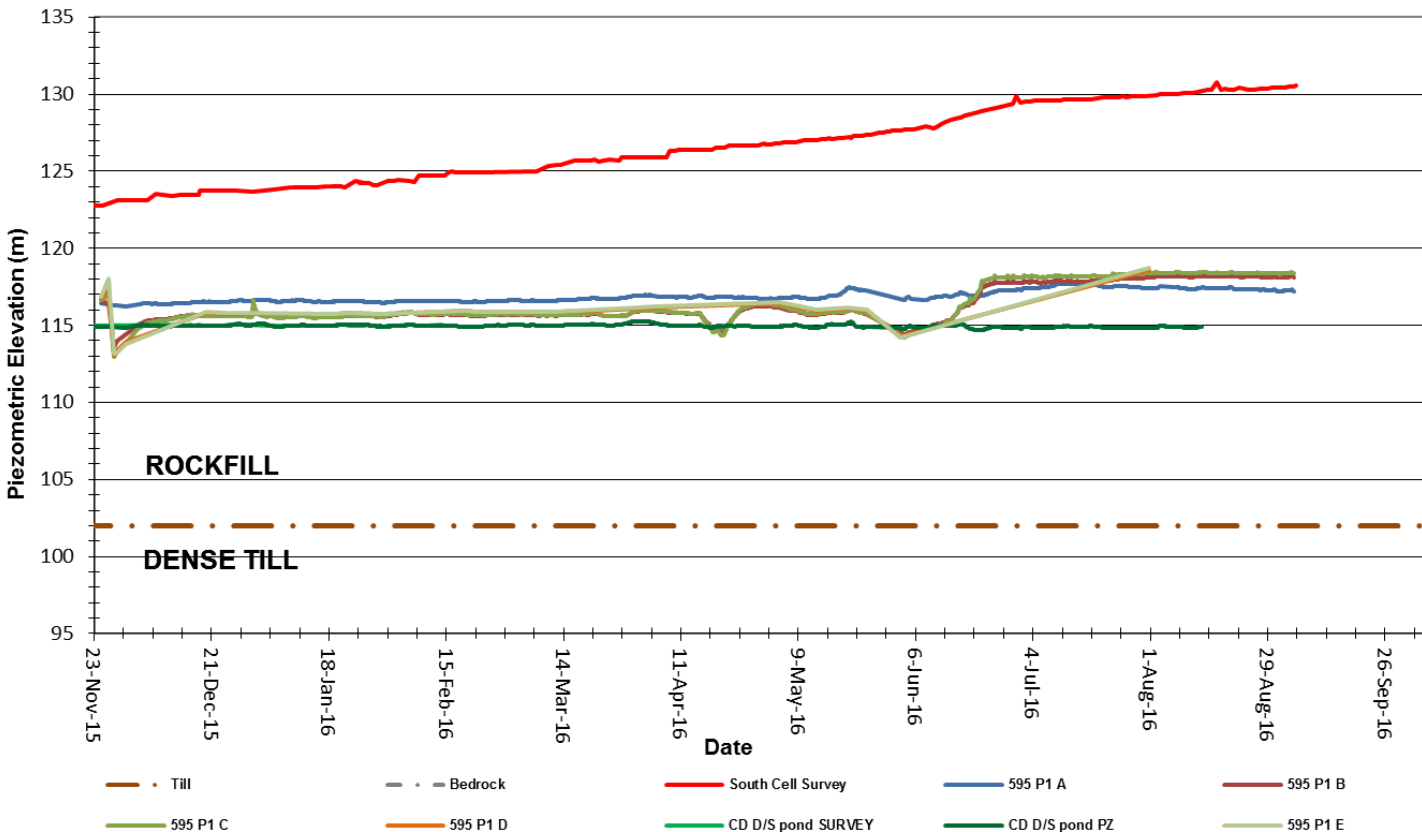

STA 595 Instrumentation

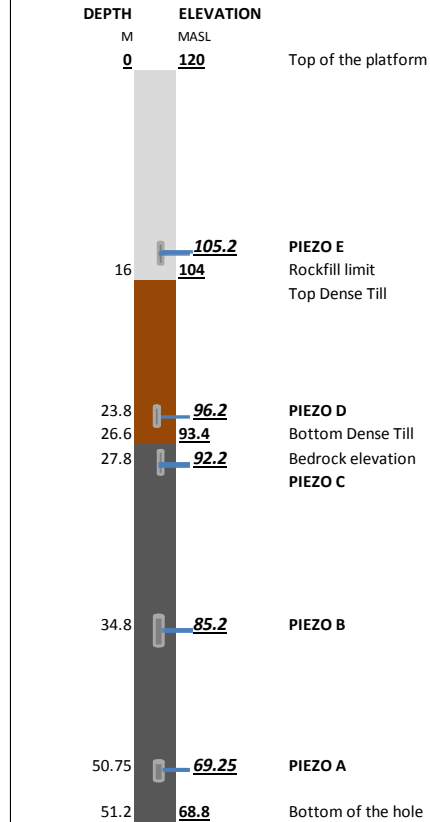

INSTRUMENTATION RESULTS

Thermistor 595*

MAY 2016

Grapher

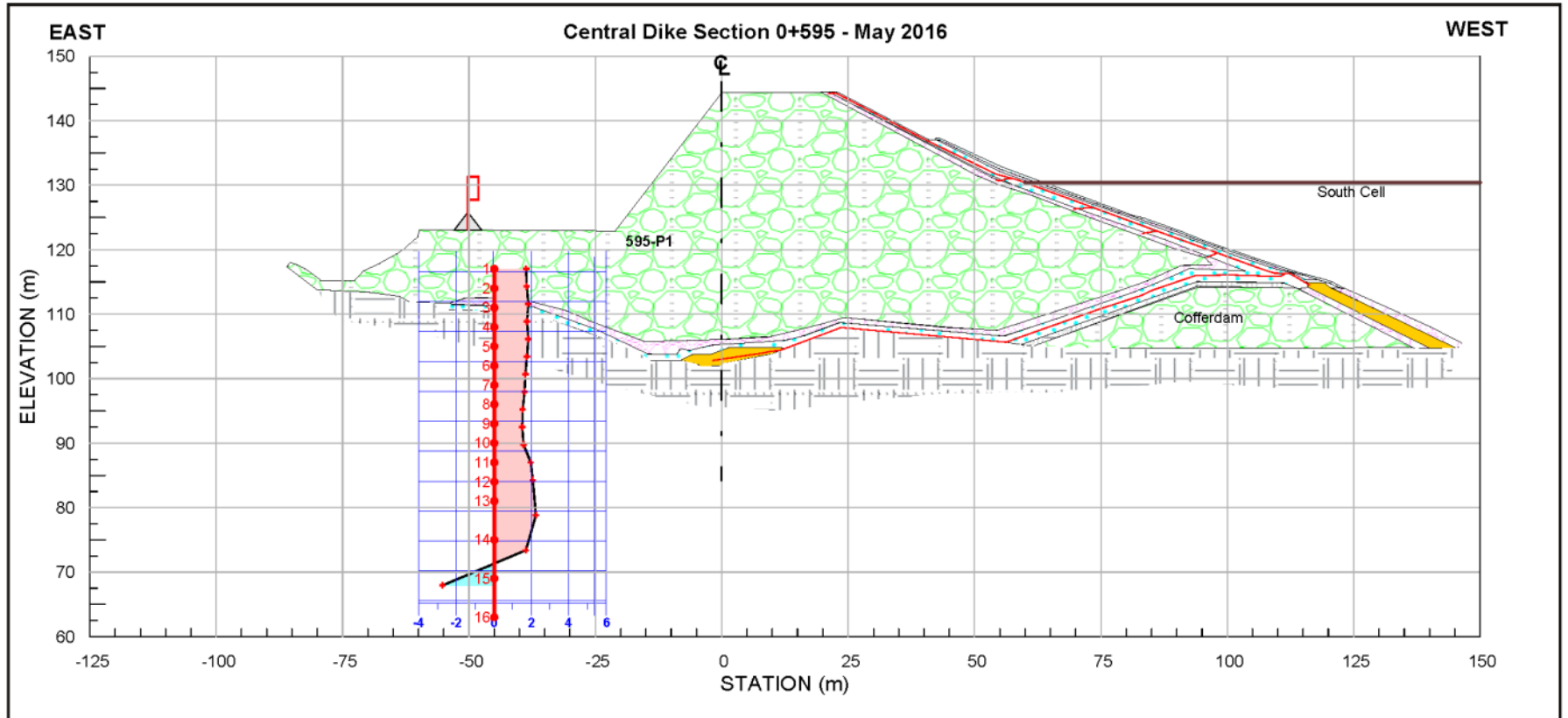
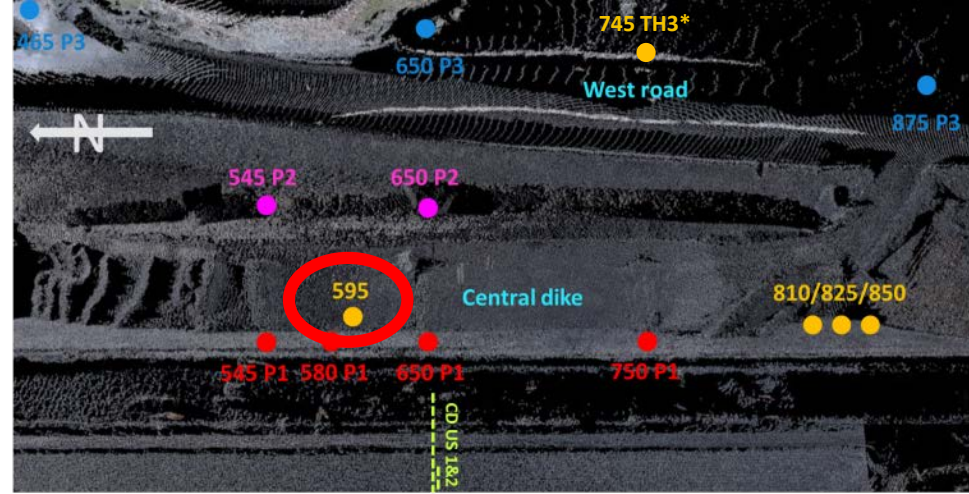

INSTRUMENTATION RESULTS

Thermistor 595*

JUNE 2016

Grapher

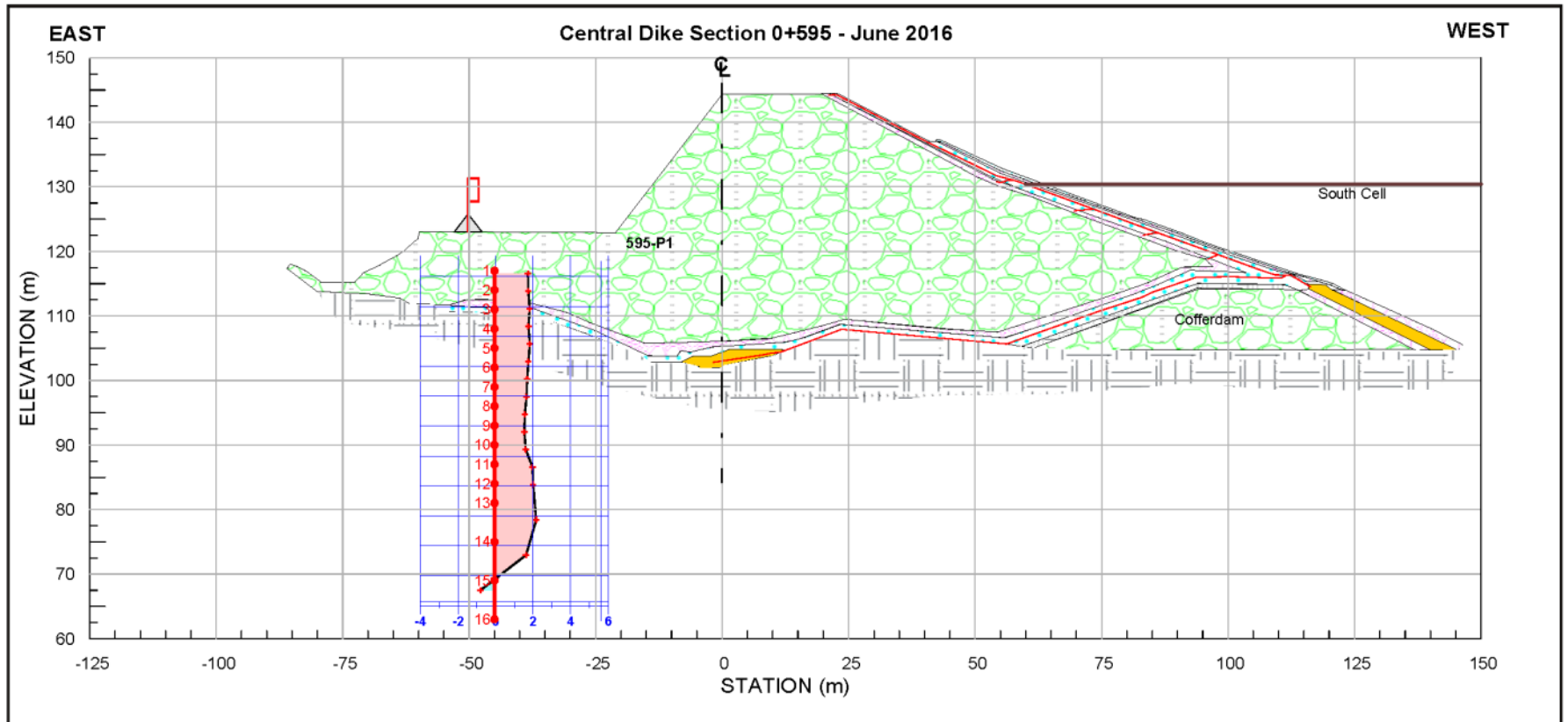
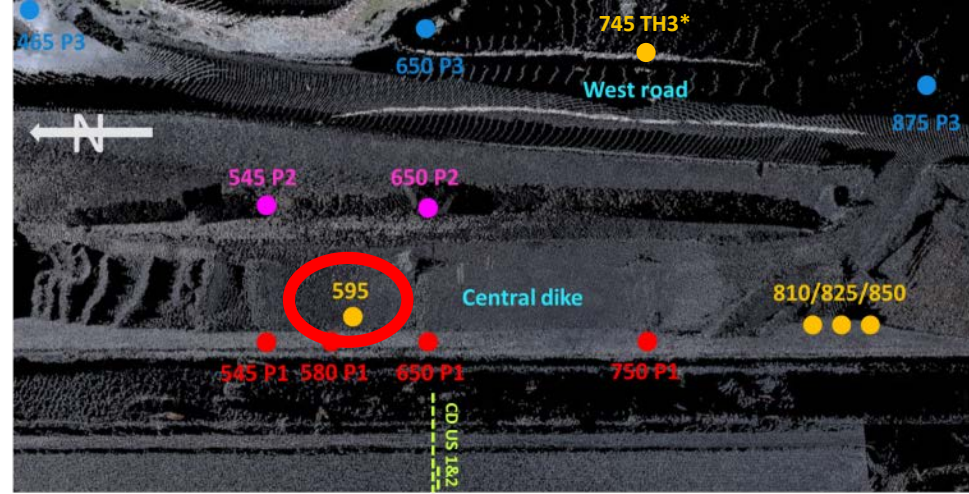

INSTRUMENTATION RESULTS

Thermistor 595*

AUGUST 2016

Grapher

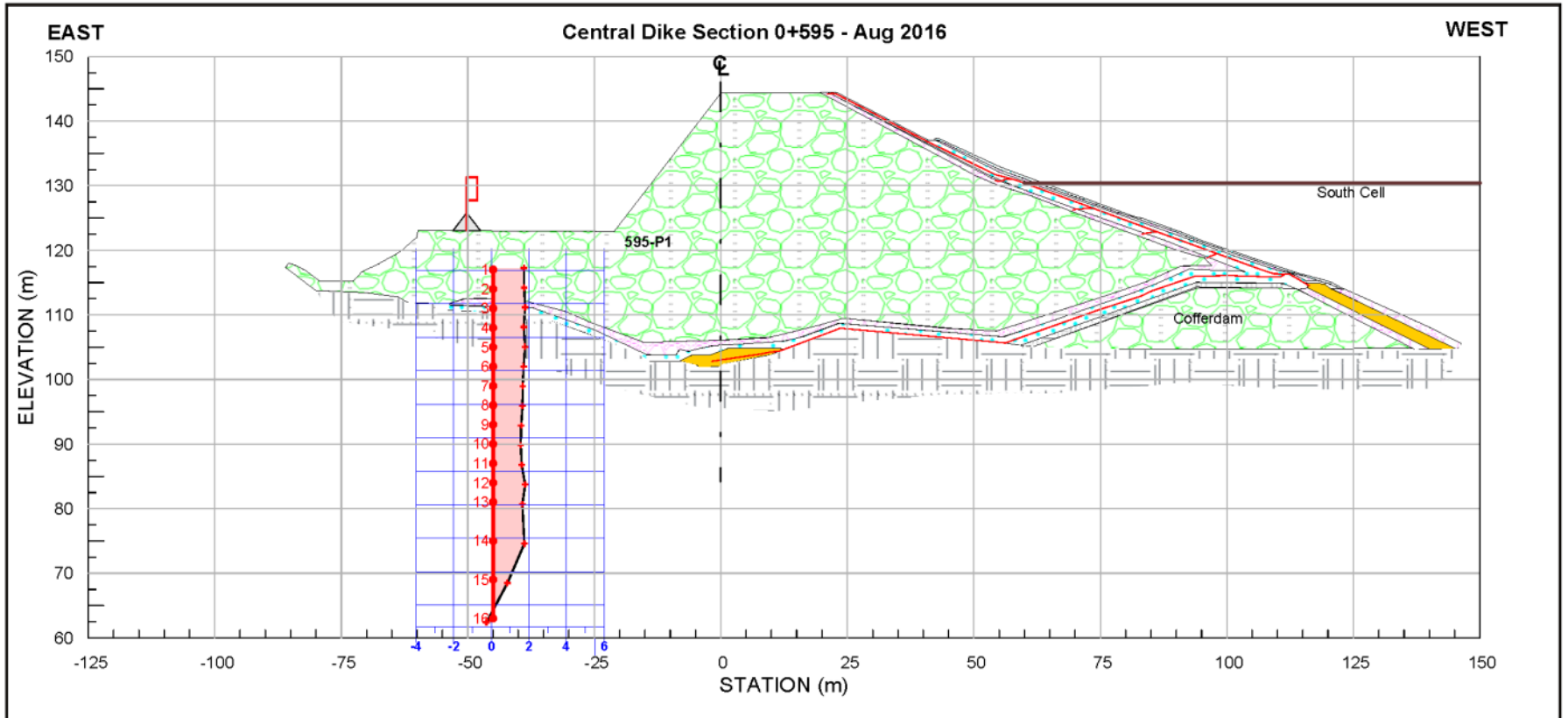
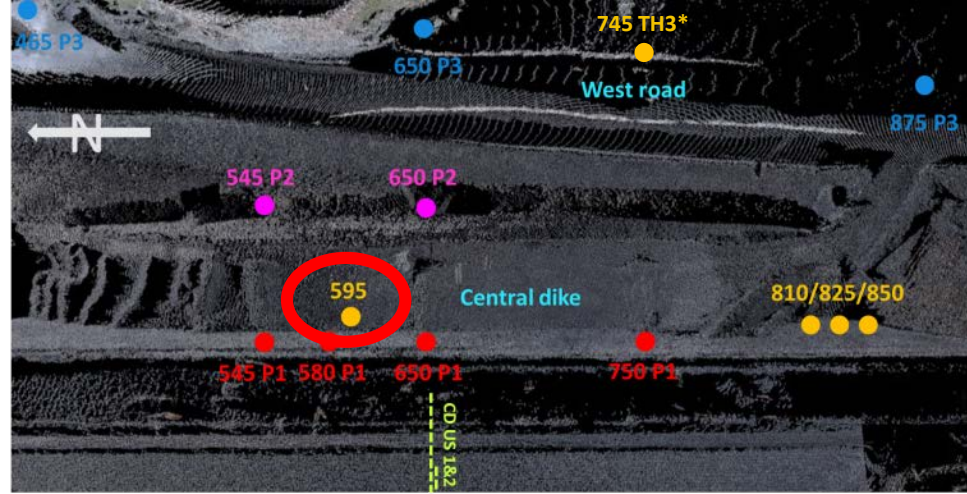

INSTRUMENTATION RESULTS

Thermistor 595*

FULL YEAR



AGNICO EAGLE

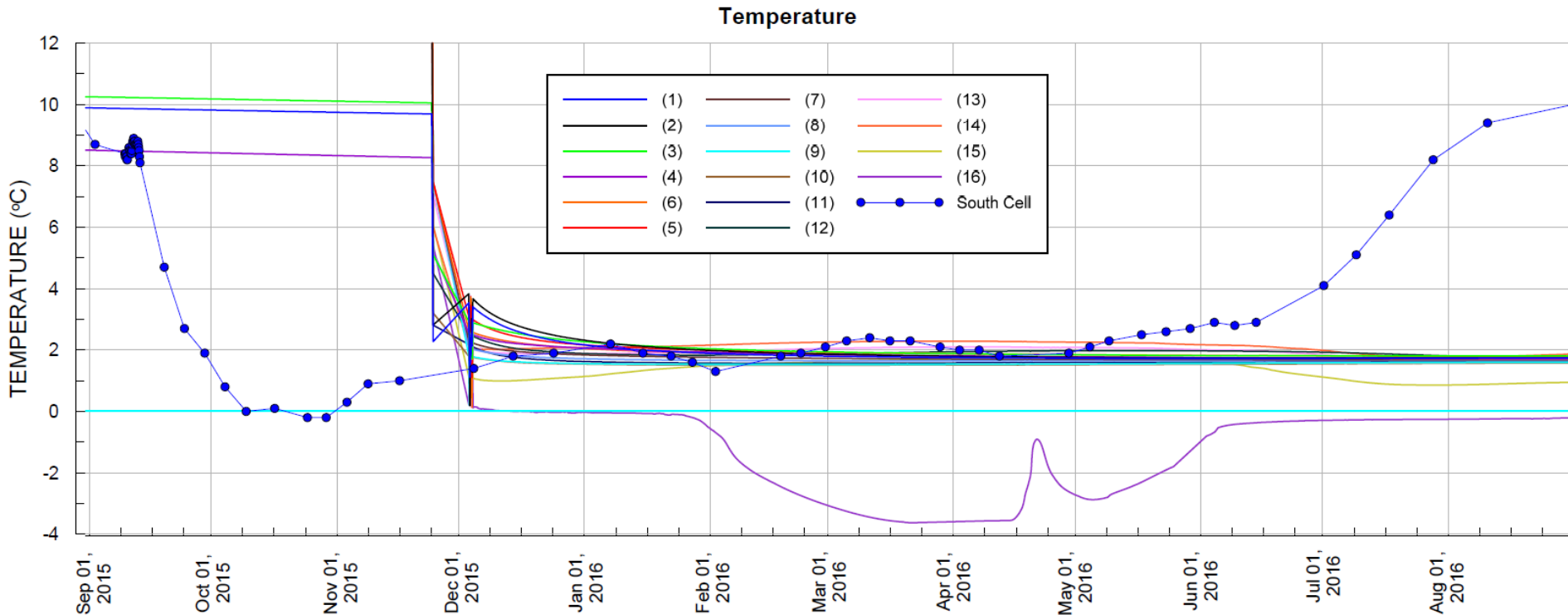
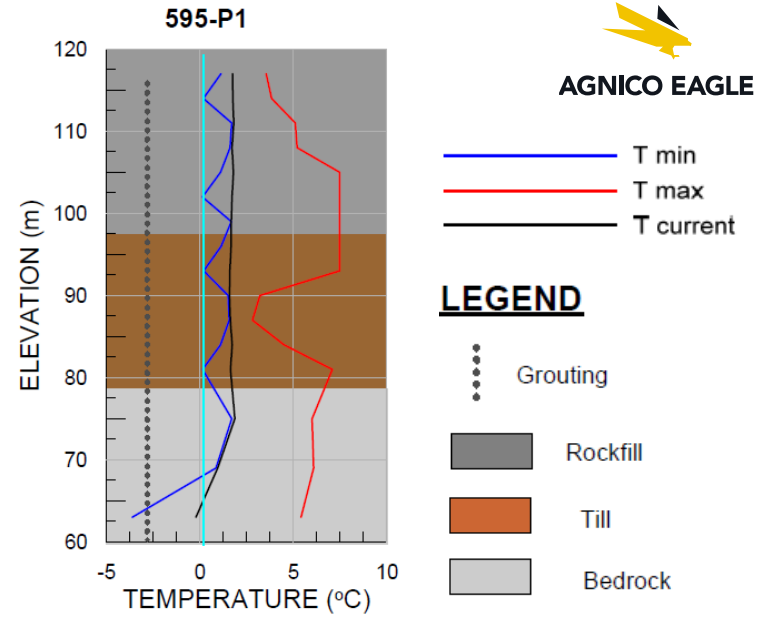

INSTRUMENTATION RESULTS

Piezometers 650 P3

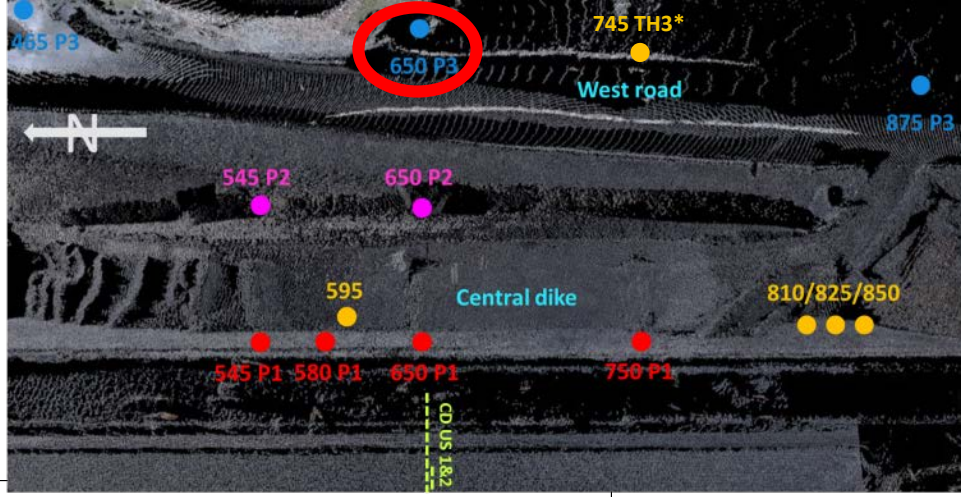

650-P3 Hole - Piezometrics Elevation and Attenuation Pond Elevation vs Time

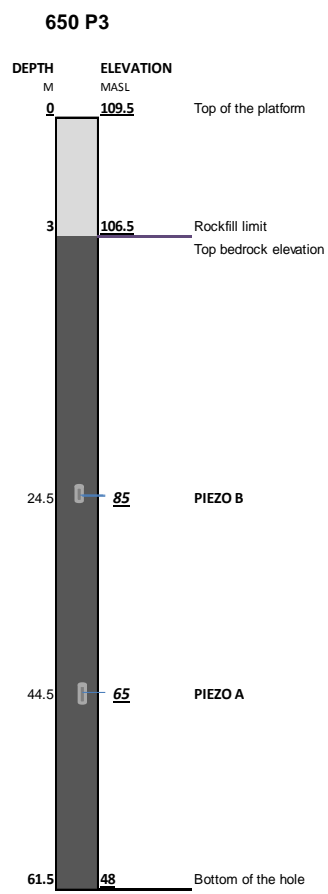
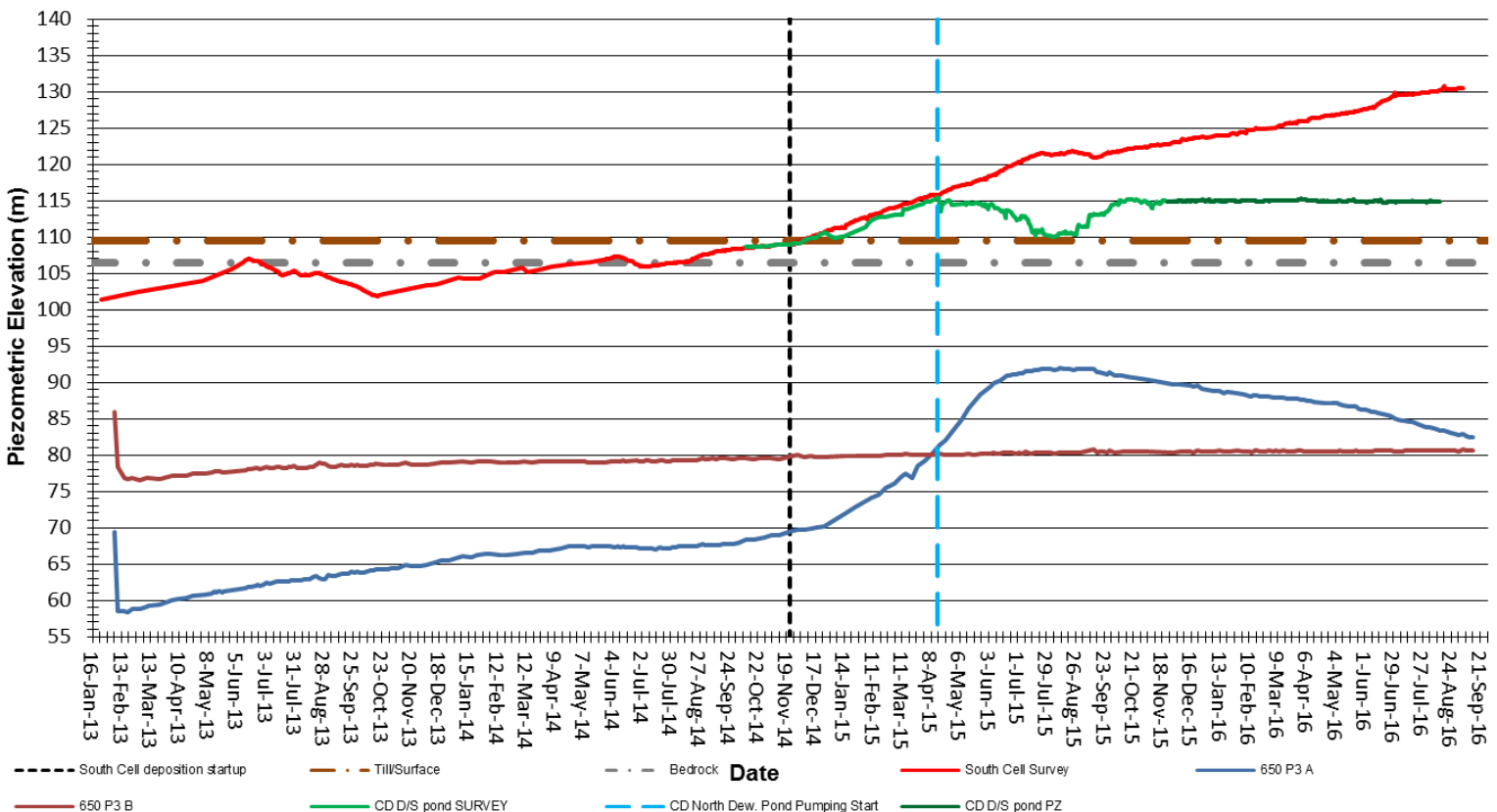

INSTRUMENTATION RESULTS

Piezometers 650 P2

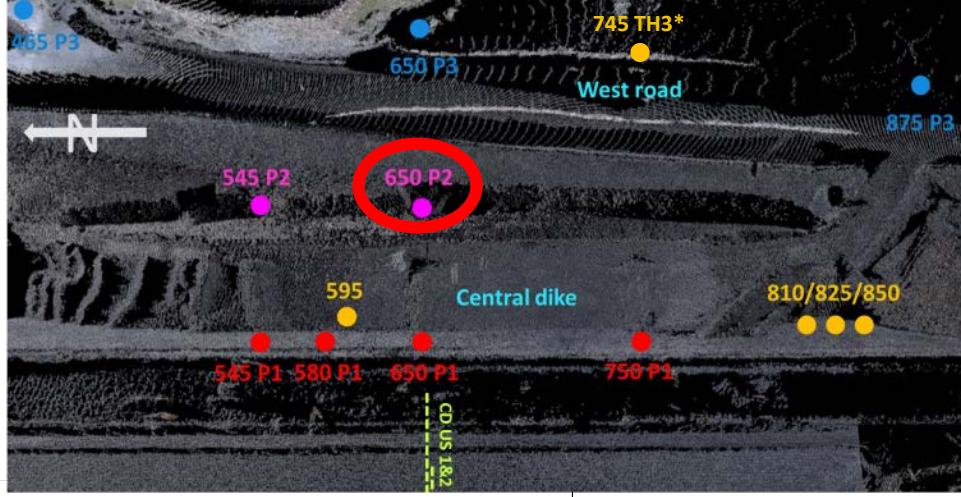

650-P2 Hole - Piezometrics Elevation and Attenuation Pond Elevation vs Time

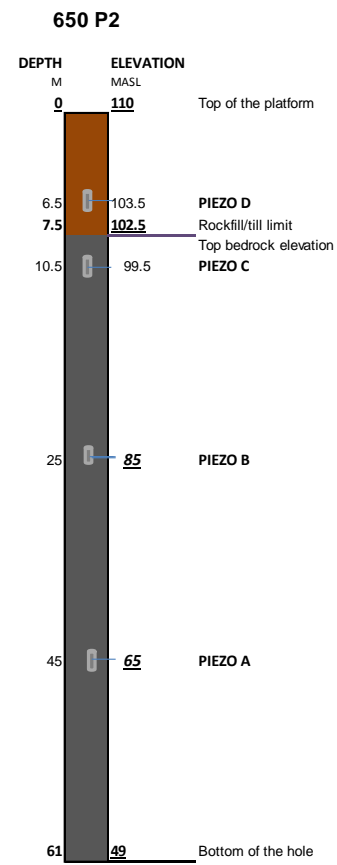
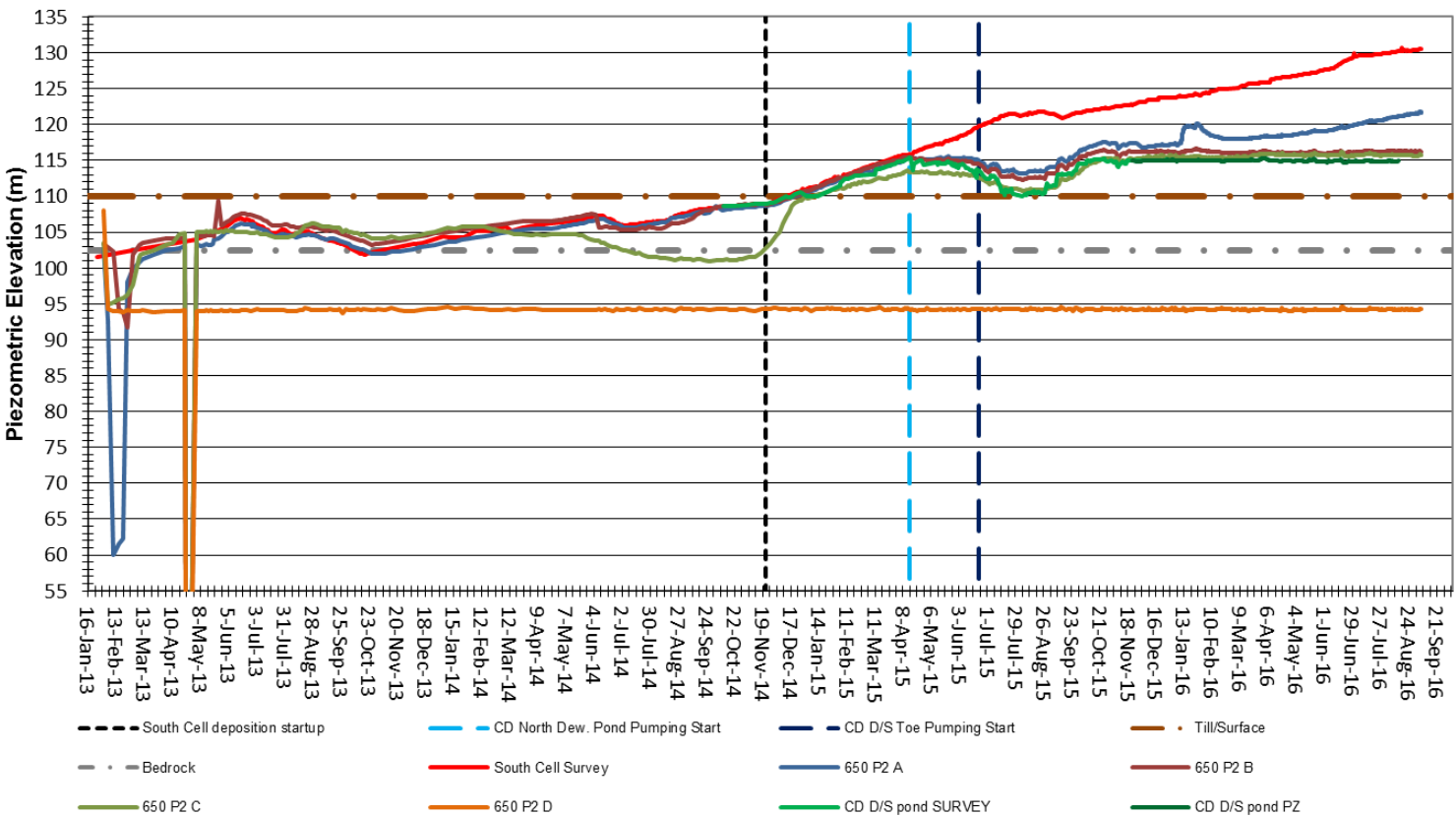

INSTRUMENTATION RESULTS

Piezometers 650 P1

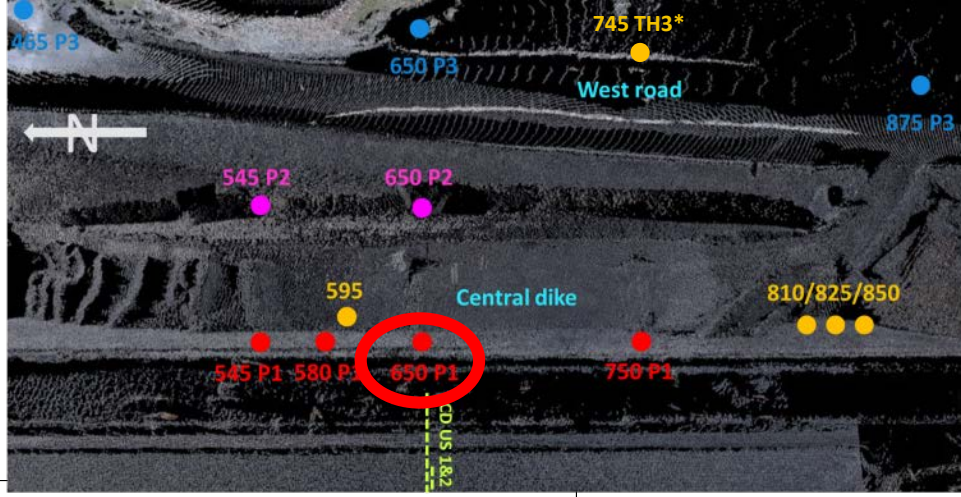

650-P1 Hole - Piezometrics Elevation and Attenuation Pond Elevation vs Time

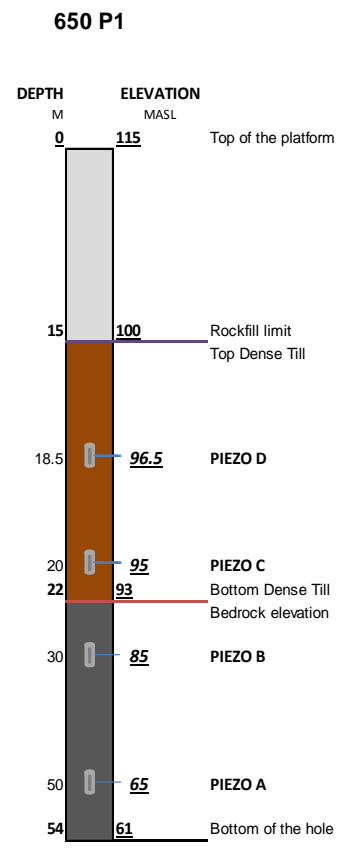
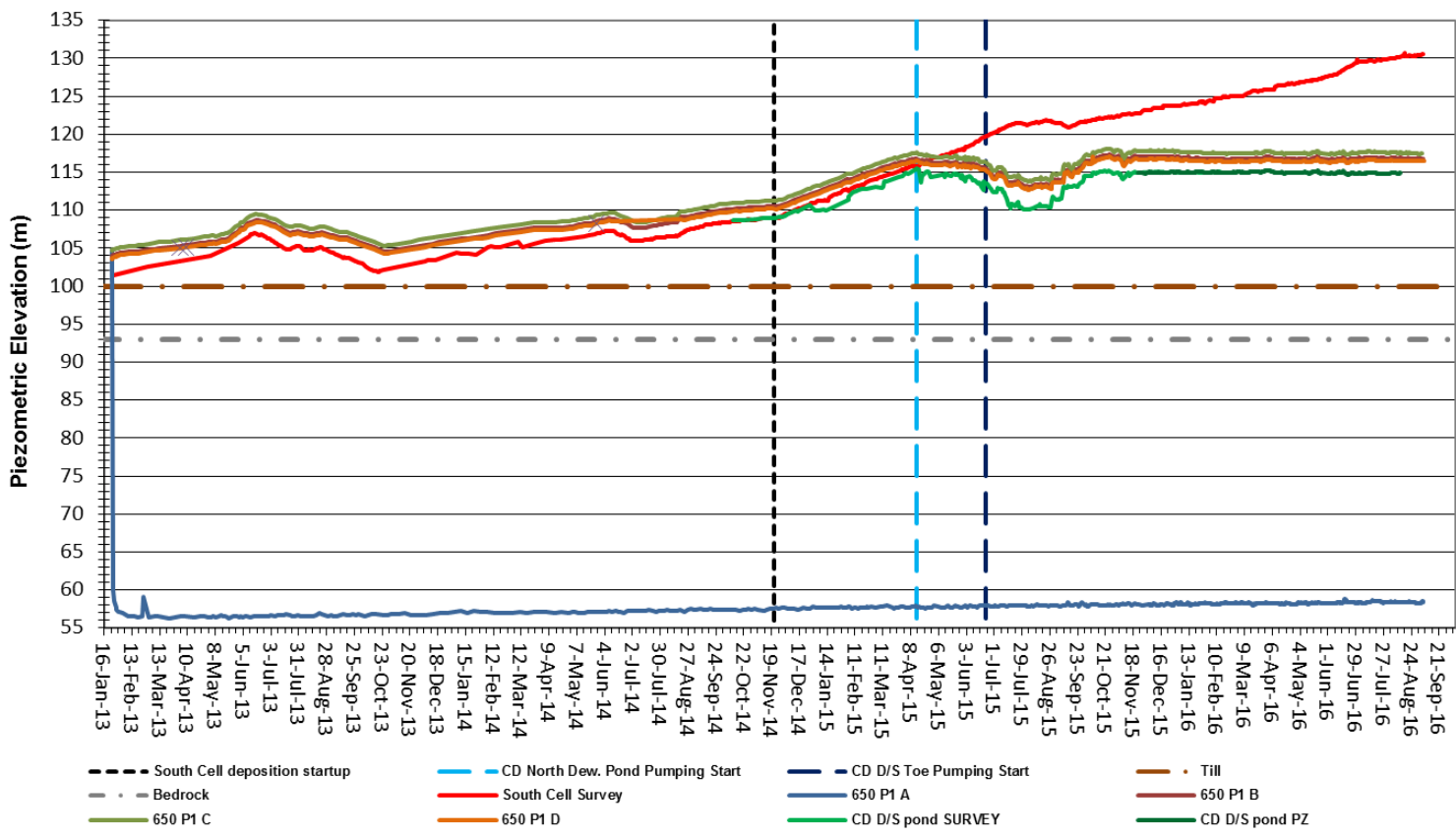

INSTRUMENTATION RESULTS

Thermistors Section 650

MAY 2016

Grapher

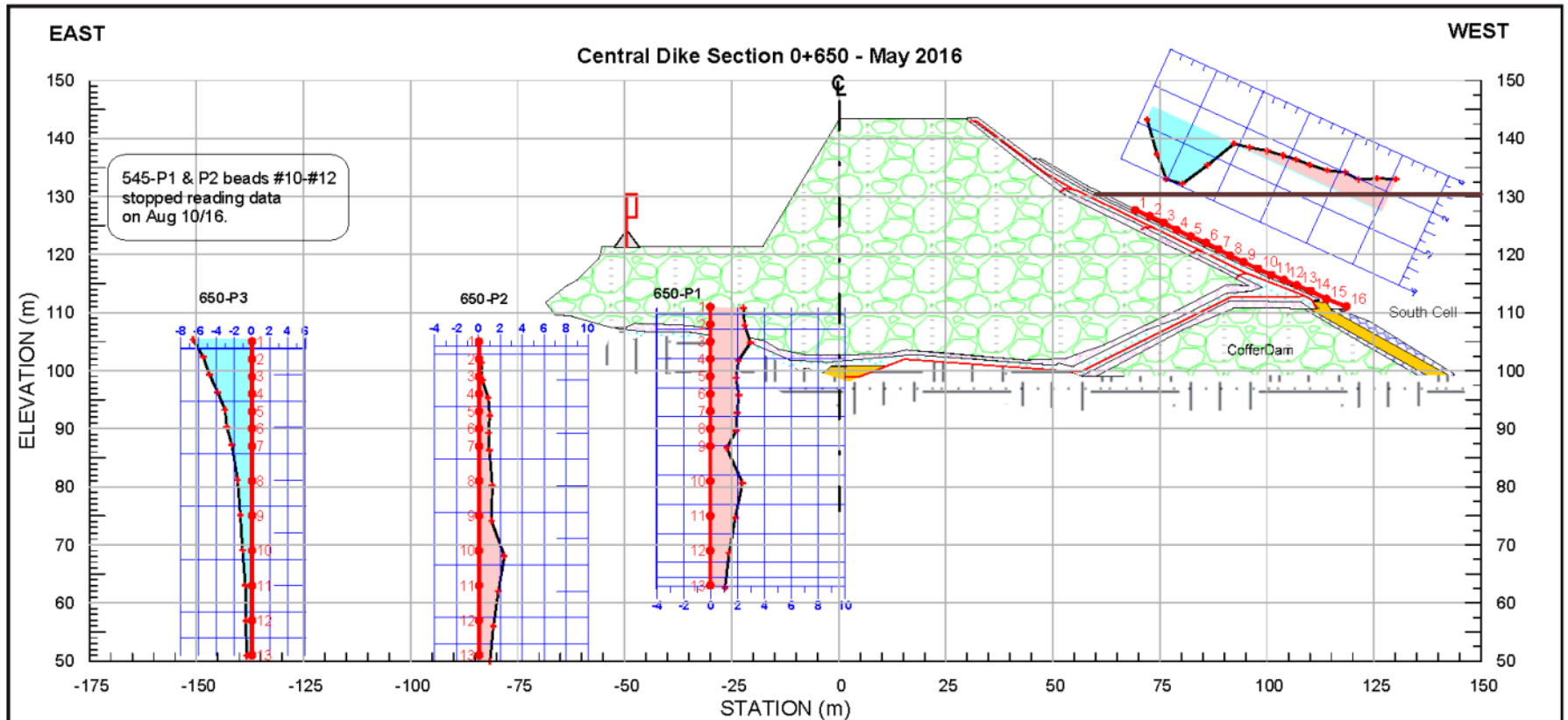
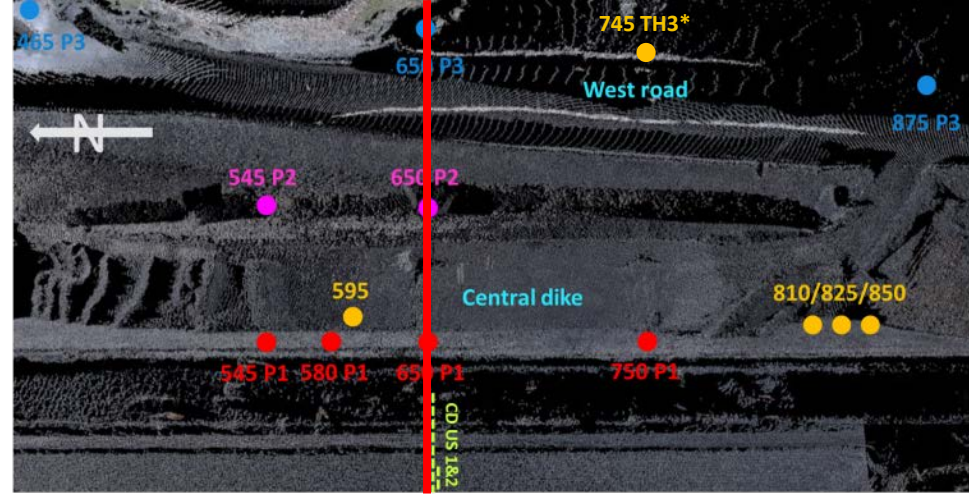

INSTRUMENTATION RESULTS

Thermistors Section 650

JUNE 2016

Grapher

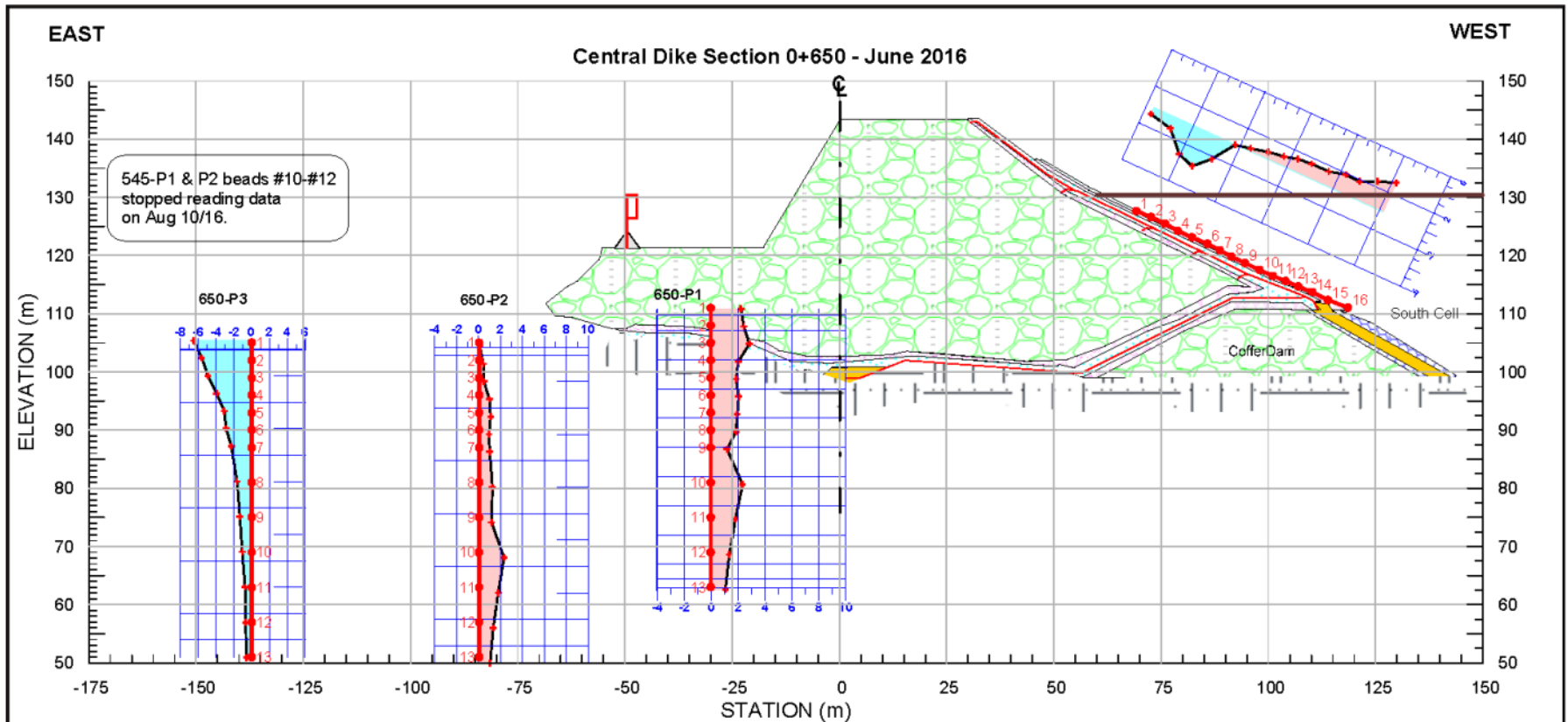
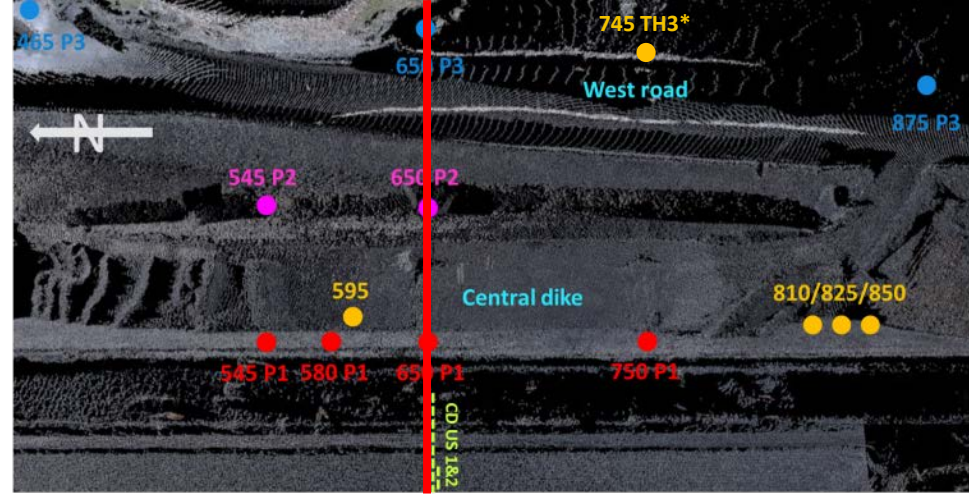

INSTRUMENTATION RESULTS

Thermistors Section 650

JULY 2016

Grapher

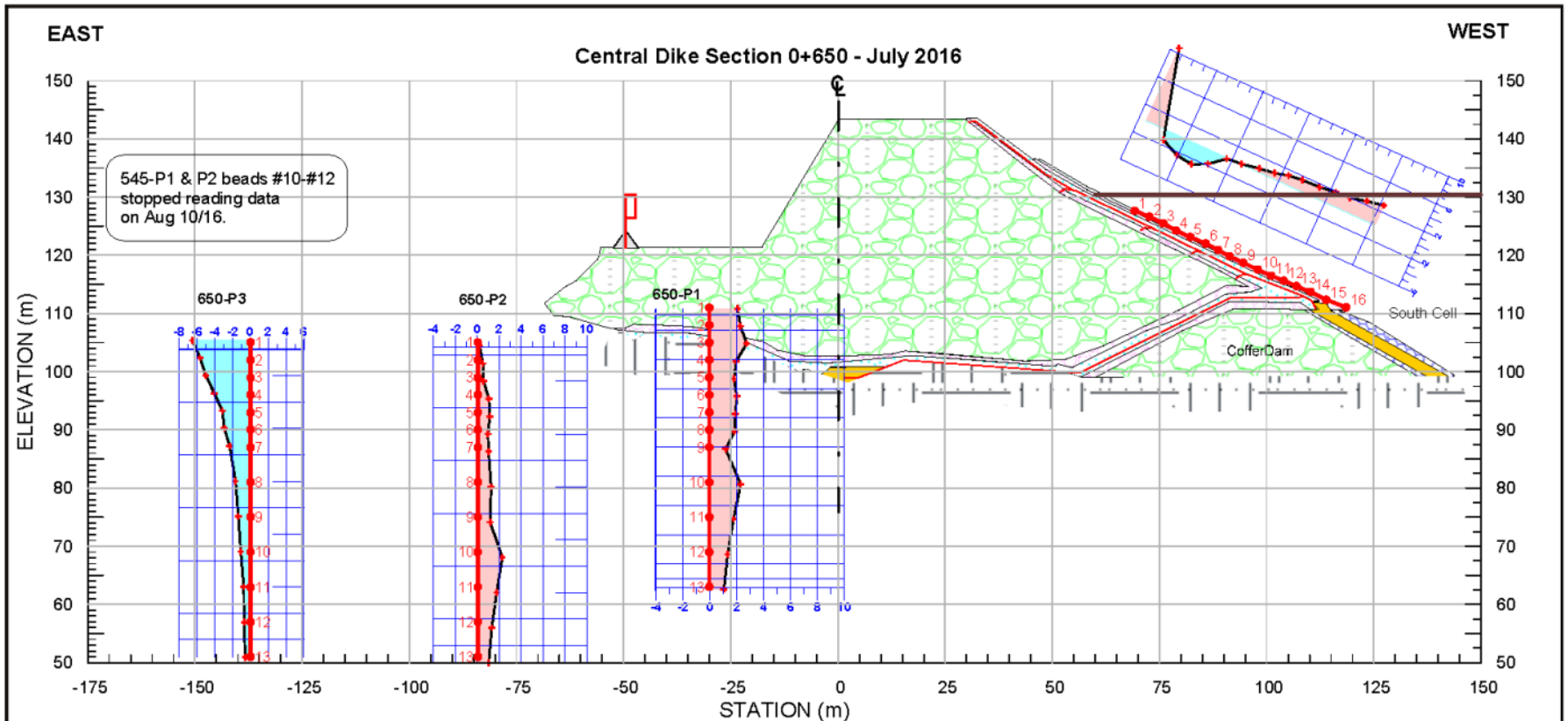
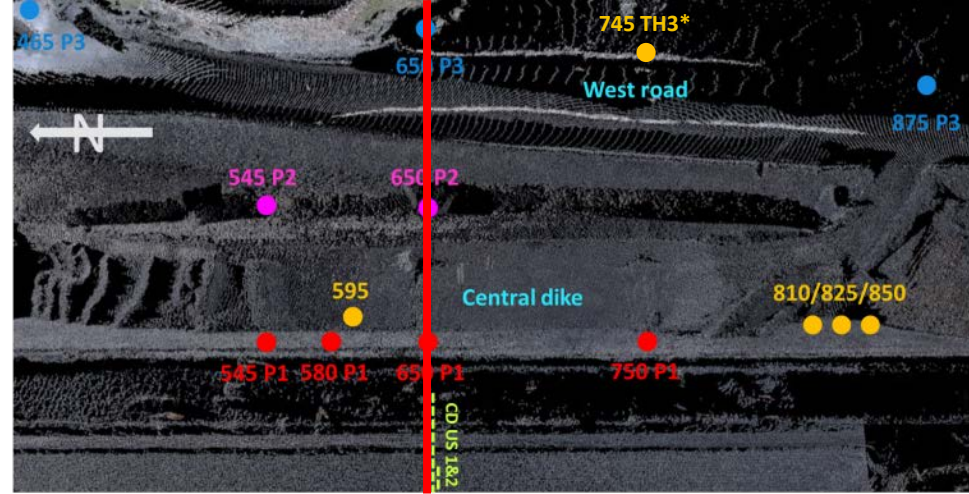

INSTRUMENTATION RESULTS

Thermistors Section 650

AUGUST 2016

Grapher

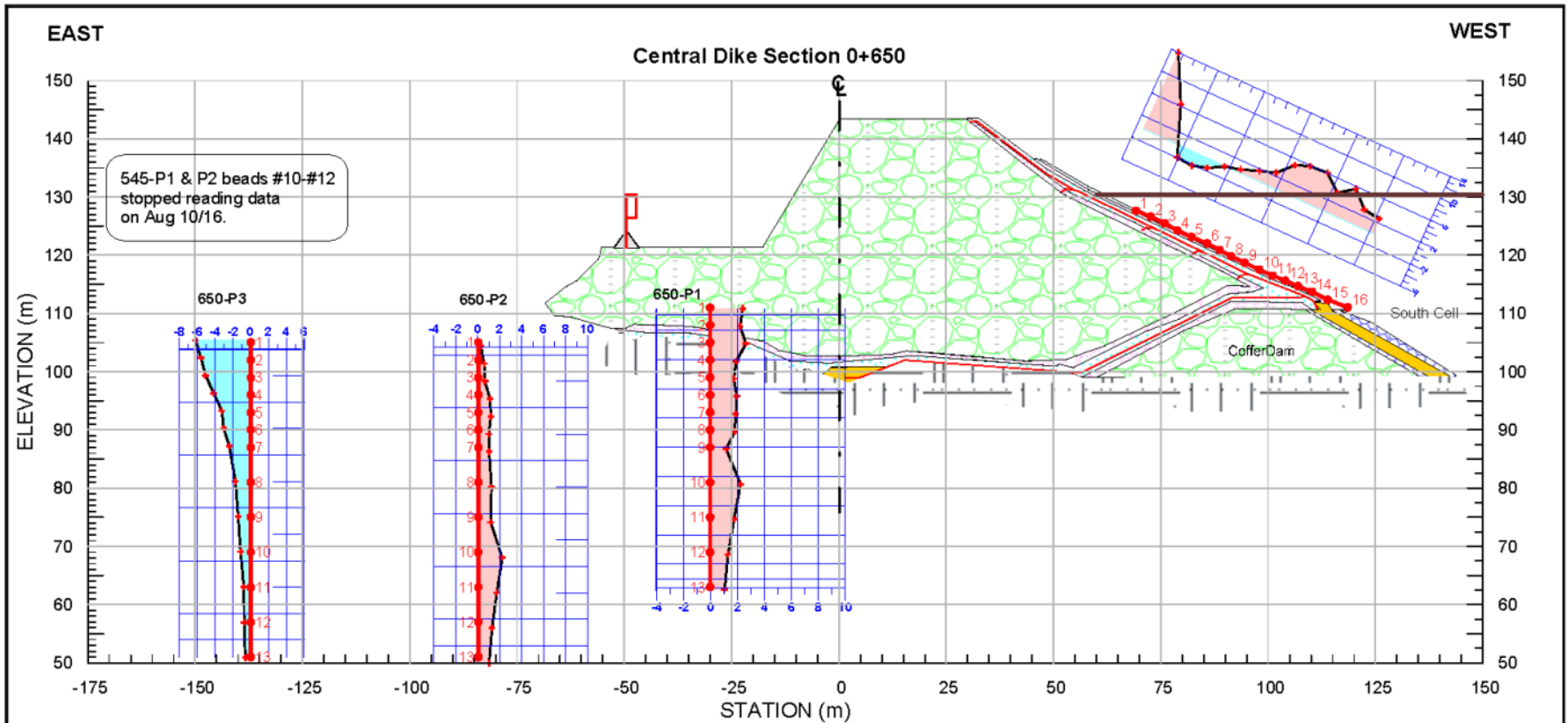
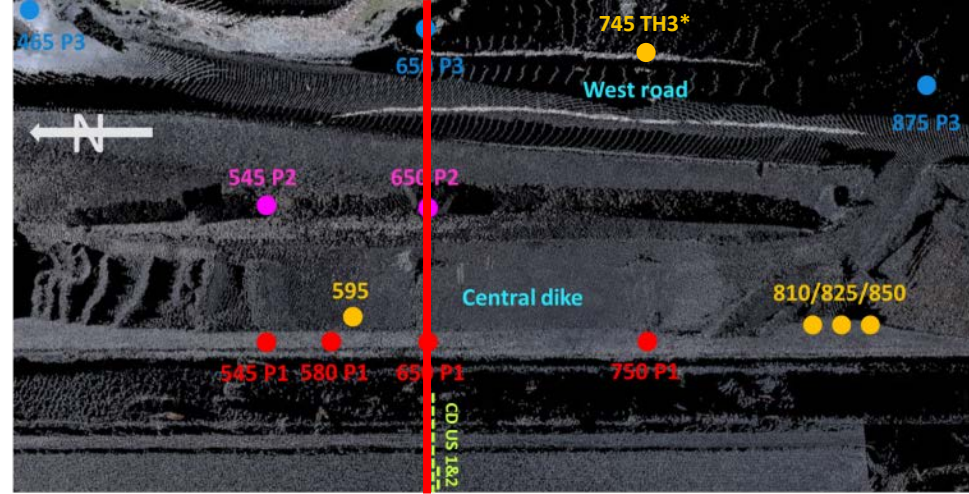

INSTRUMENTATION RESULTS

Thermistors Section 650

FULL YEAR 650 P1



AGNICO EAGLE

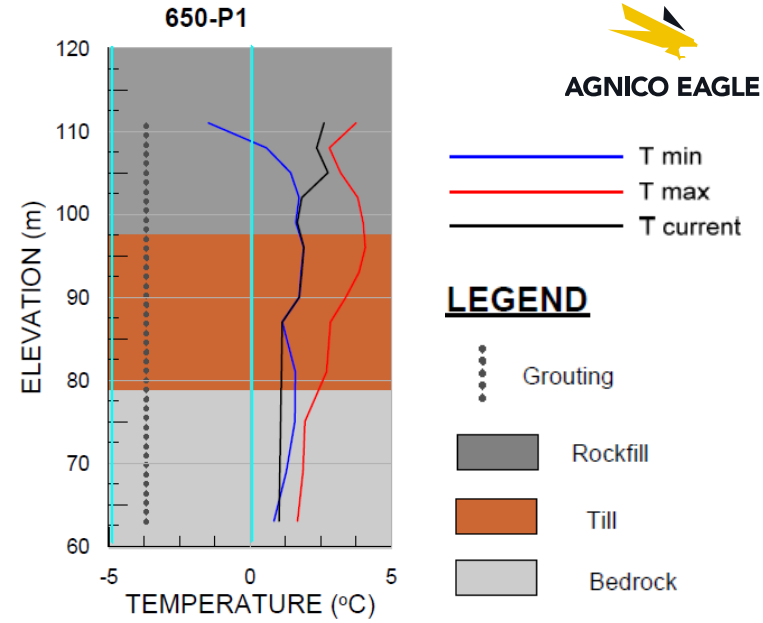

Temperature - 650-P1

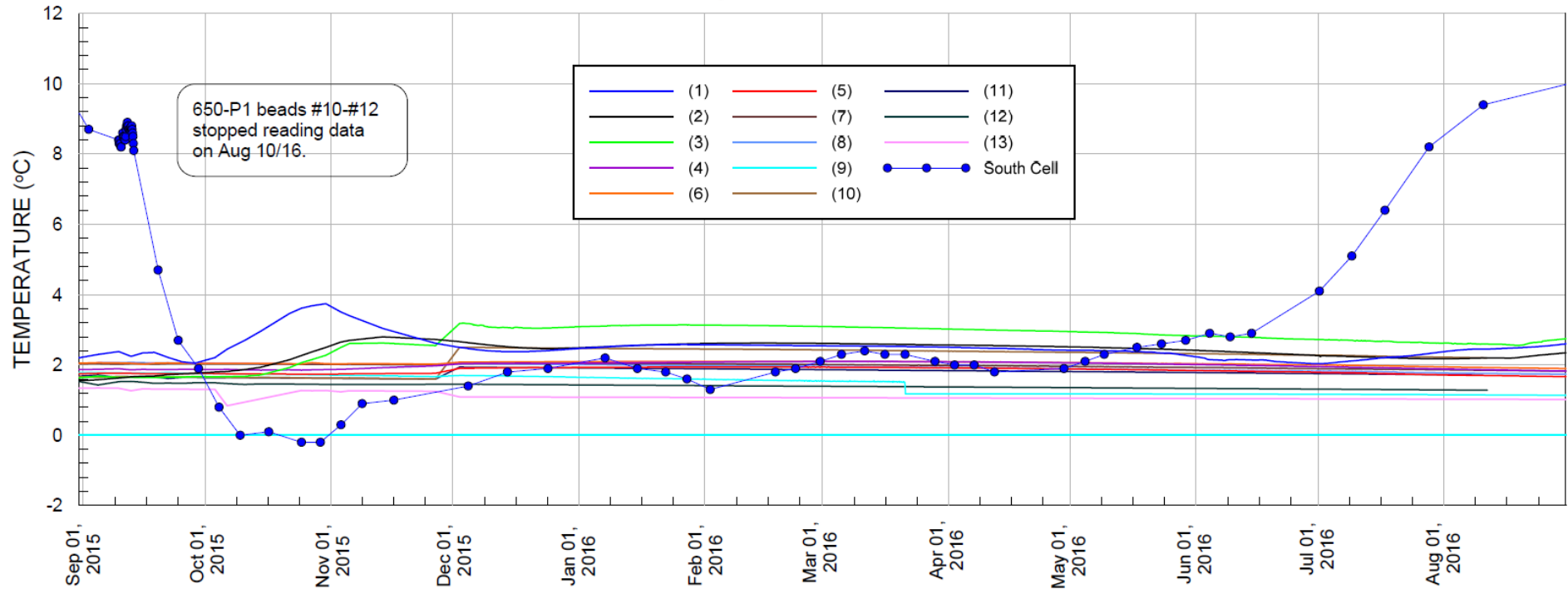

INSTRUMENTATION RESULTS

Thermistors Section 650

FULL YEAR 650 P2



AGNICO EAGLE

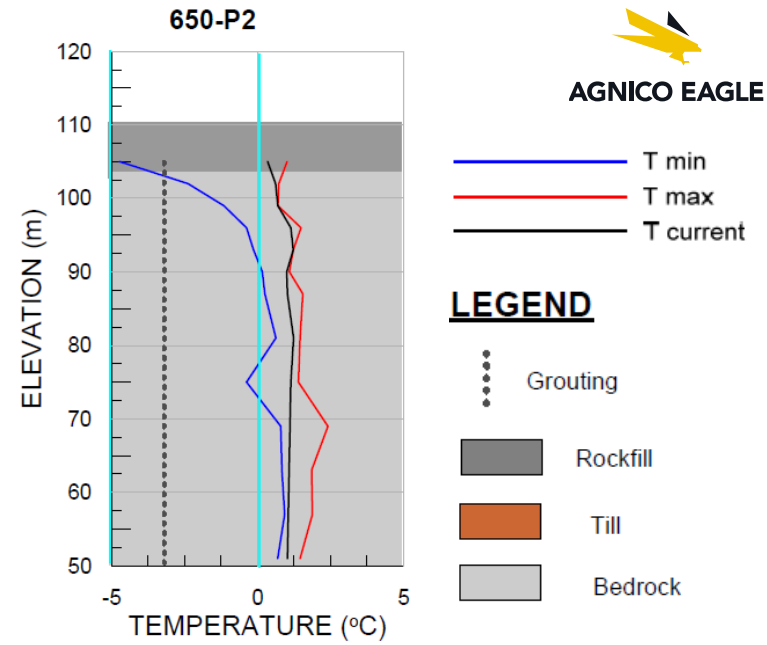

Temperature - 650 - P2

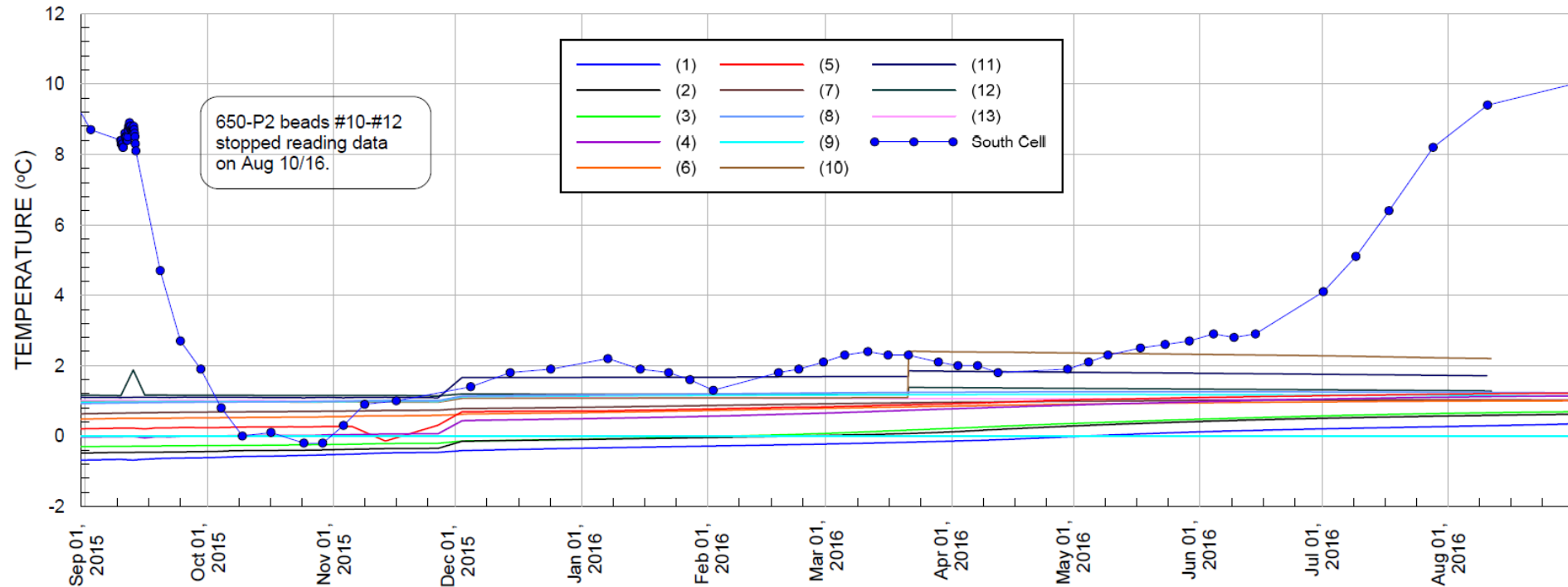

INSTRUMENTATION RESULTS

Thermistors Section 650

FULL YEAR 650 P3



AGNICO EAGLE

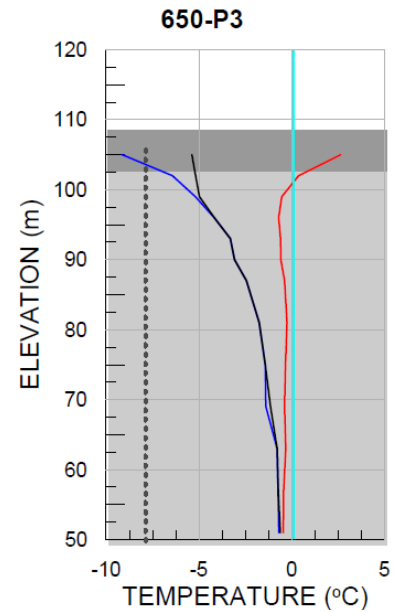

— T min
— T max
— T current

LEGEND

- Grouting
- Rockfill
- Till
- Bedrock

Temperature - 650-P3

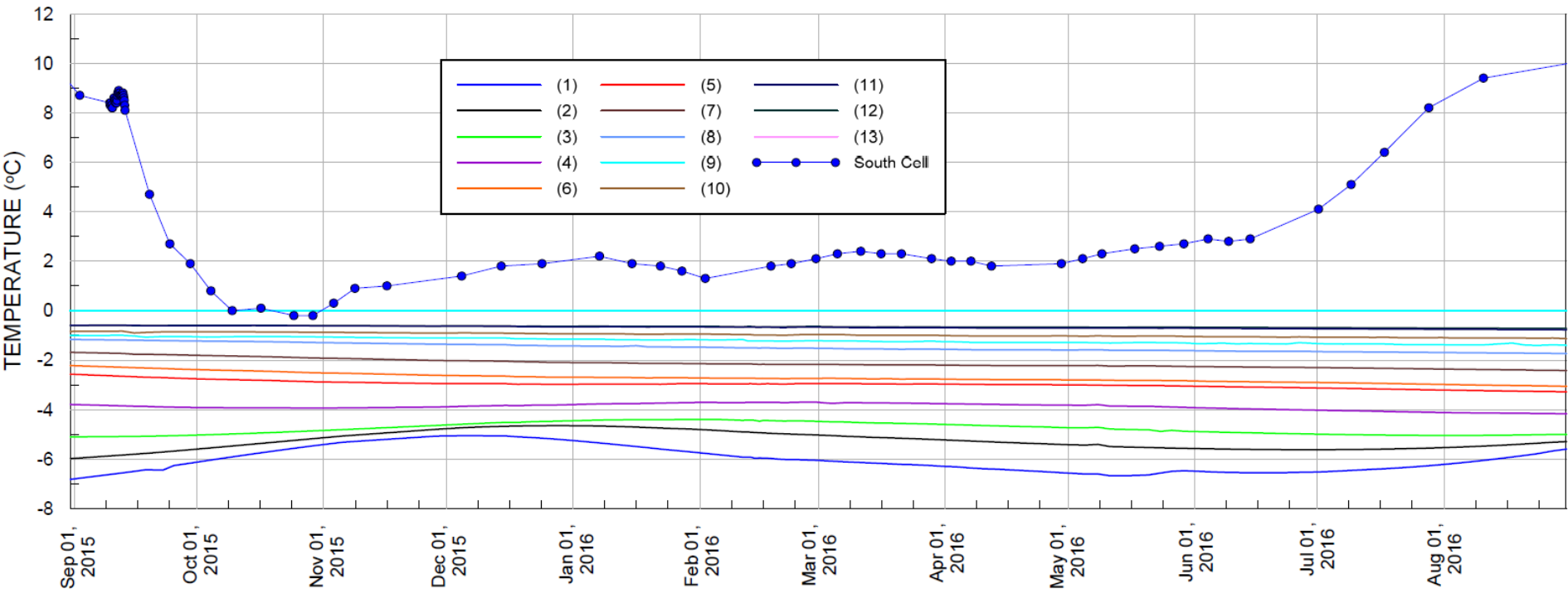

(1) (5) (11)
(2) (7) (12)
(3) (8) (13)
(4) (9) South Cell
(6) (10)

INSTRUMENTATION RESULTS

Thermistors TH 745 P3

FULL YEAR 745 P3*

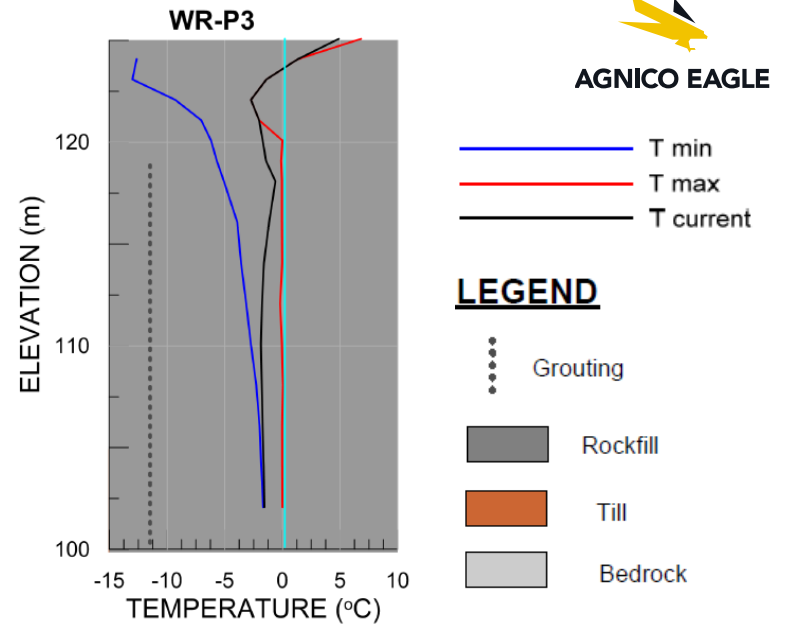
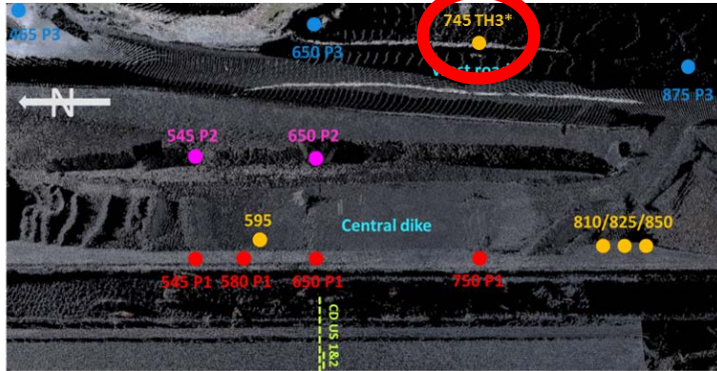

Temperature

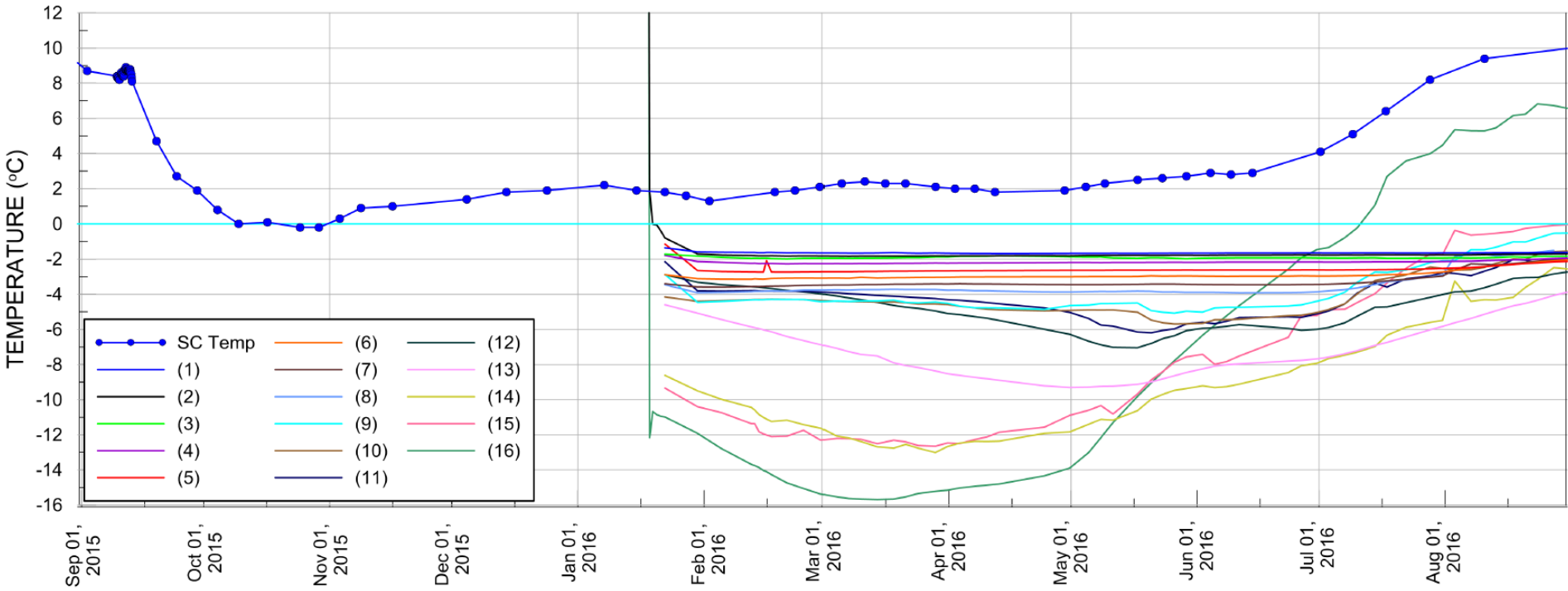

INSTRUMENTATION RESULTS

Piezometers 750 P1

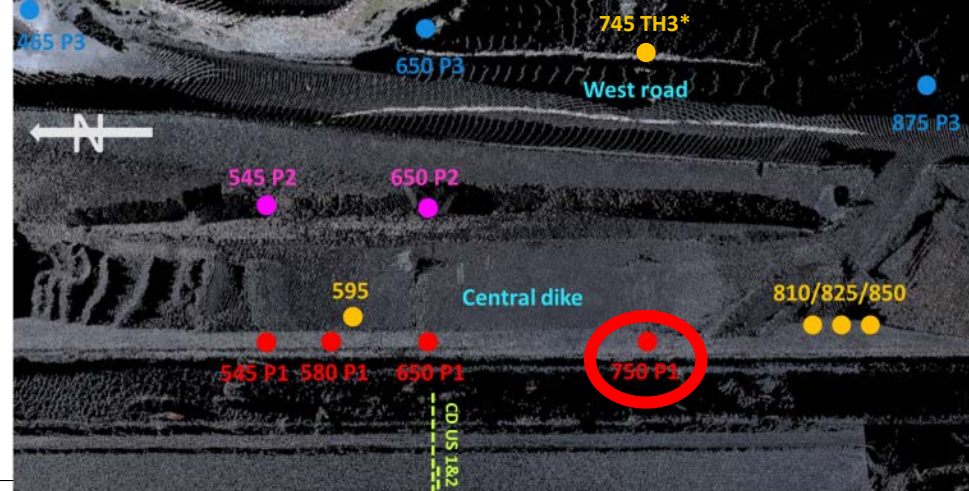

750-P1 Hole - Piezometrics Elevation and Attenuation Pond Elevation vs Time

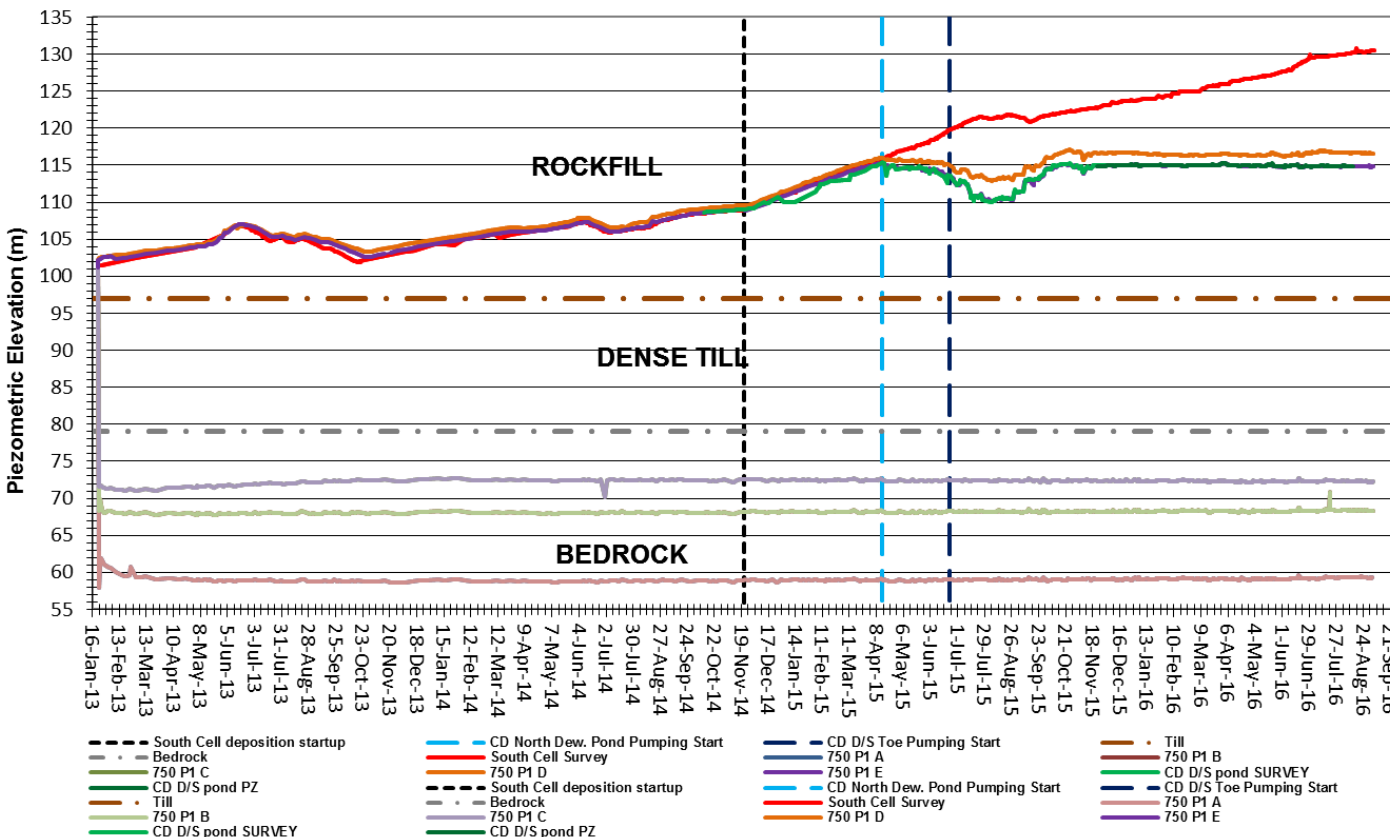

750 P1

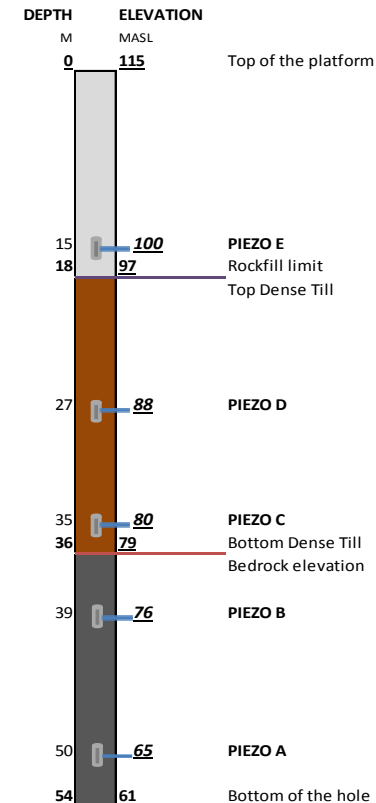

INSTRUMENTATION RESULTS

Thermistors 750 P1

MAY 2016

Grapher

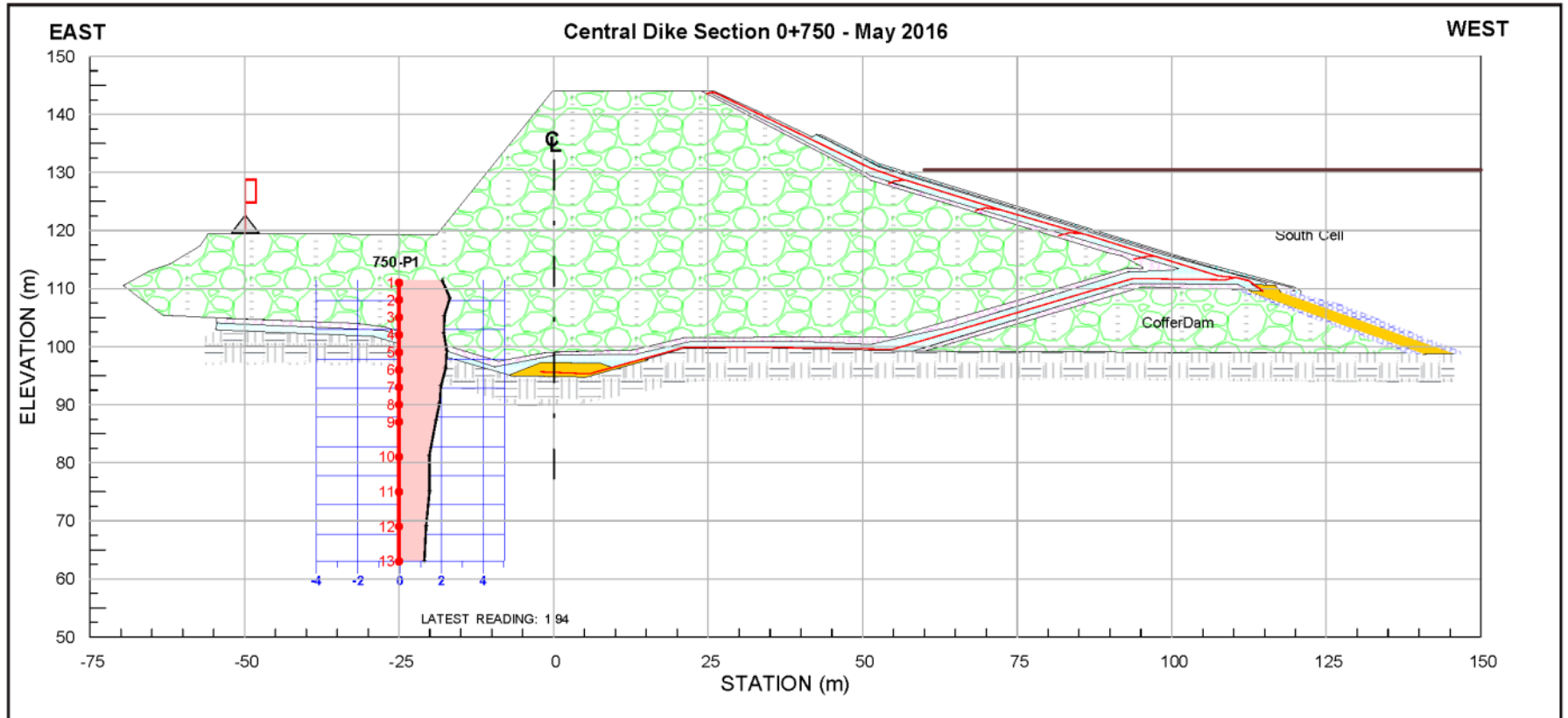
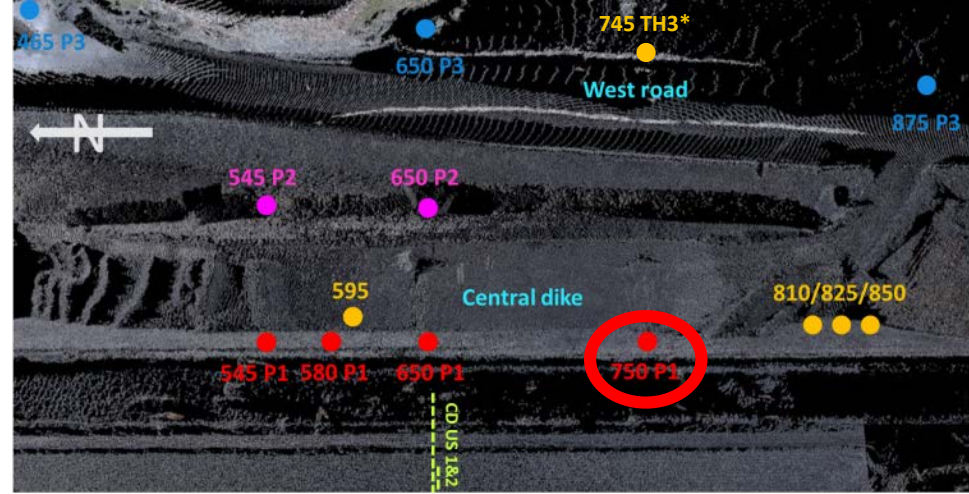

INSTRUMENTATION RESULTS

Thermistors 750 P1

JUNE 2016

Grapher

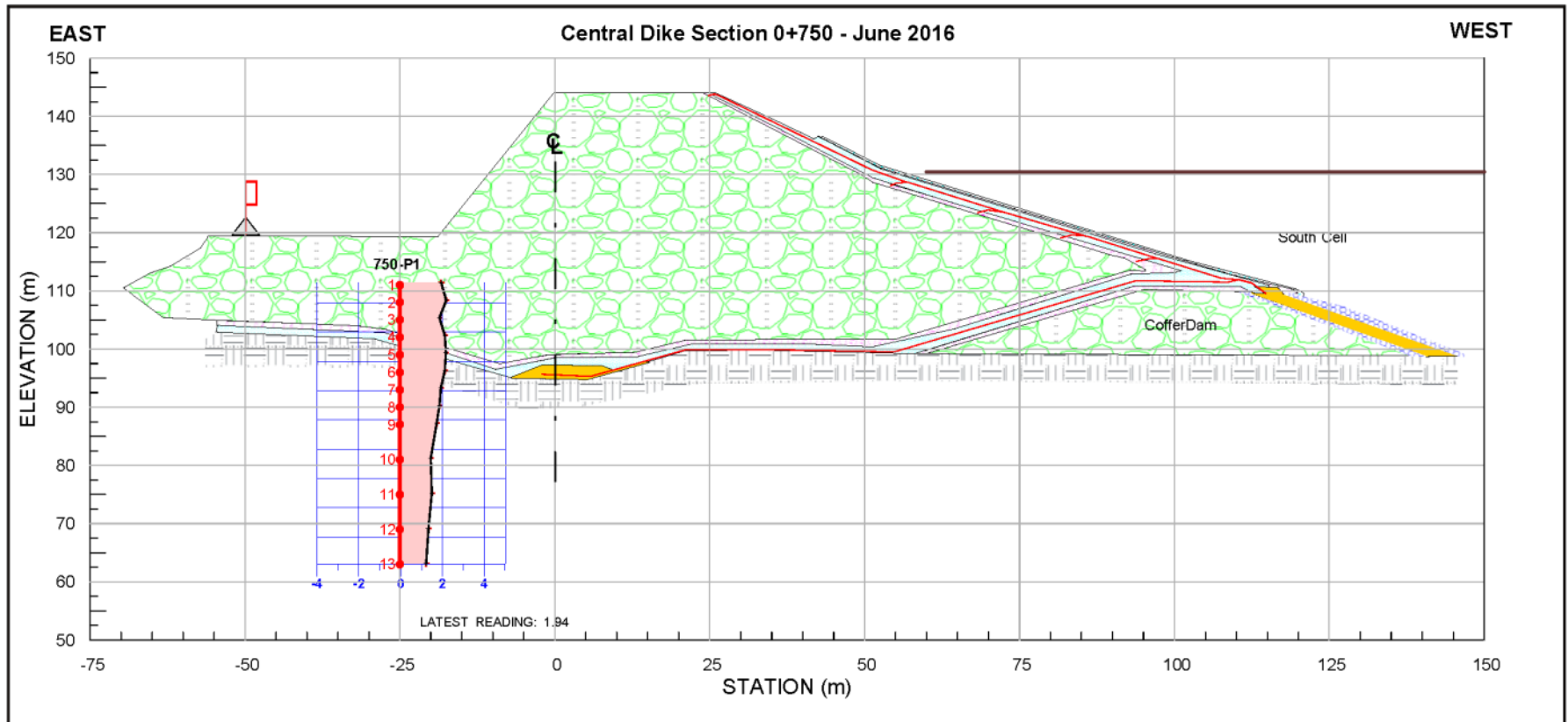
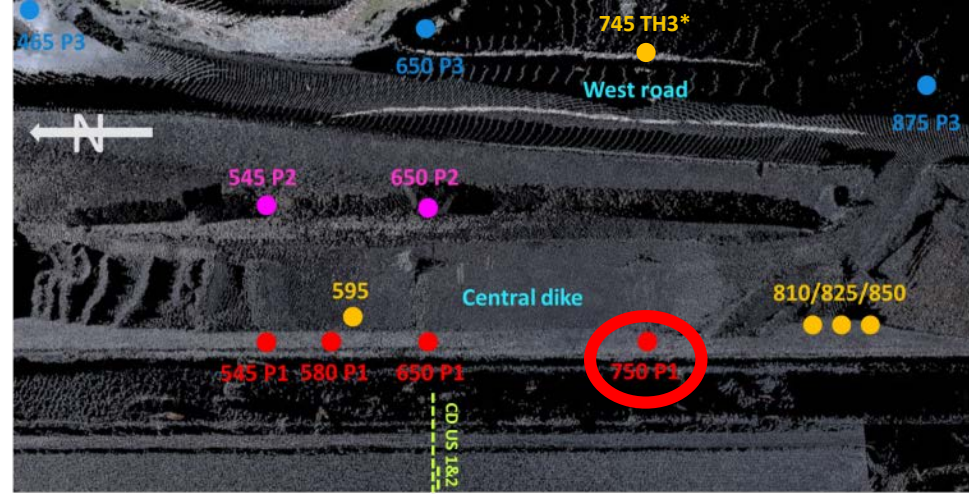

INSTRUMENTATION RESULTS

Thermistors 750 P1

JULY 2016

Grapher

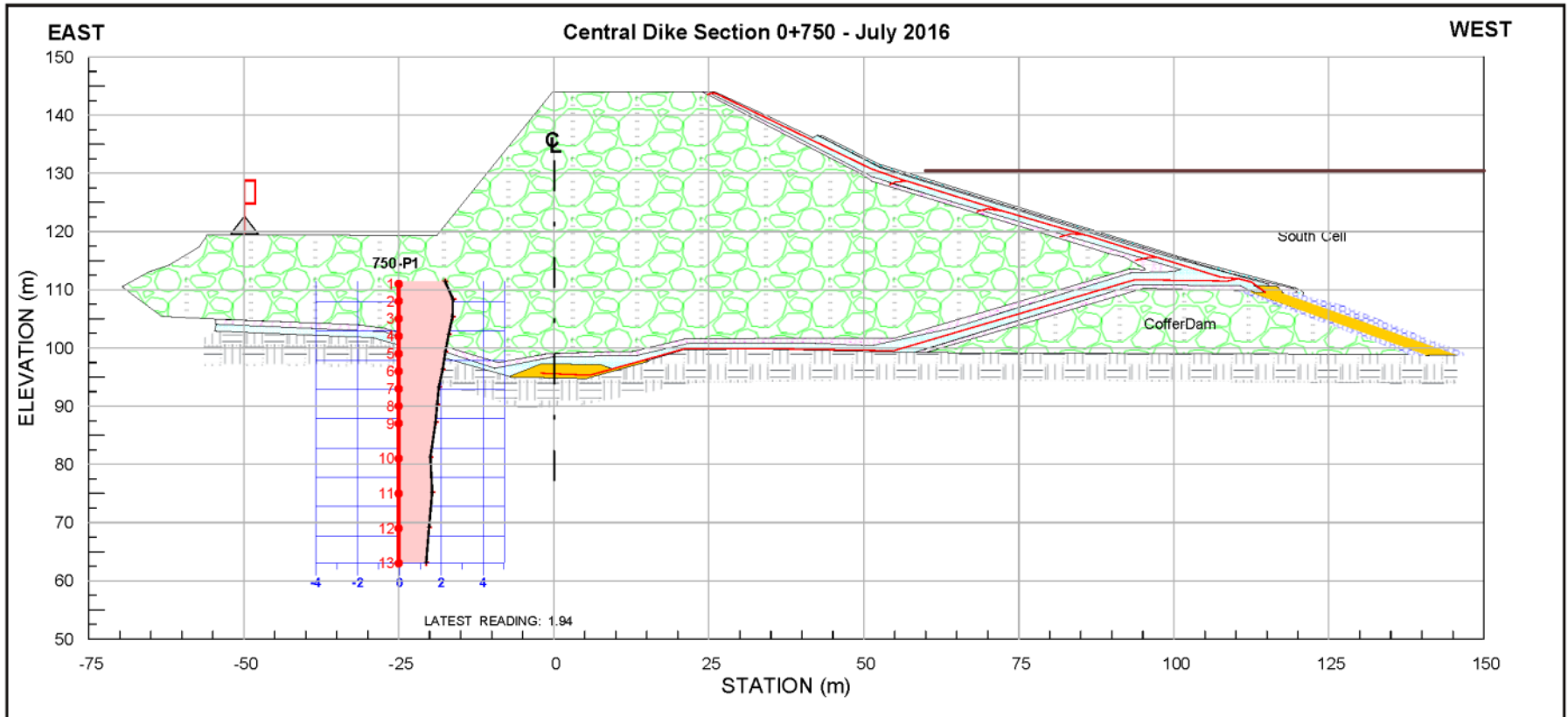
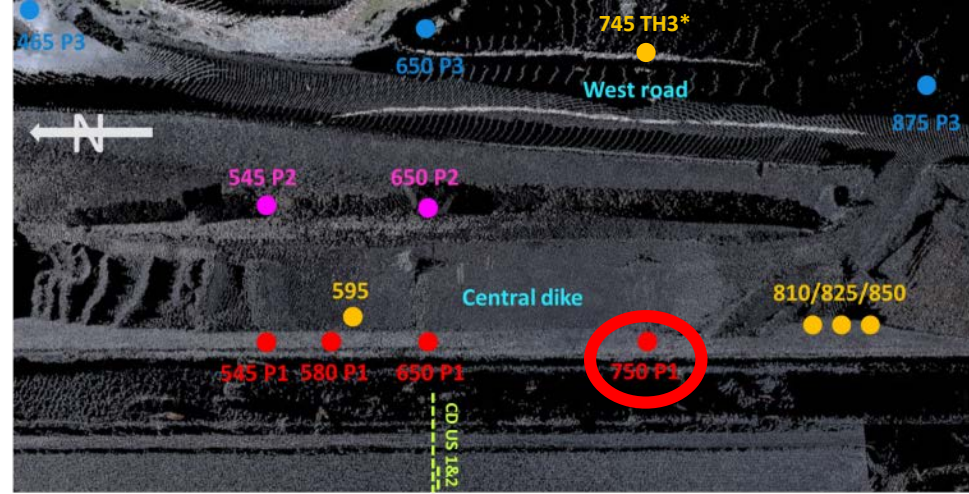

INSTRUMENTATION RESULTS

Thermistors 750 P1

AUGUST 2016

Grapher

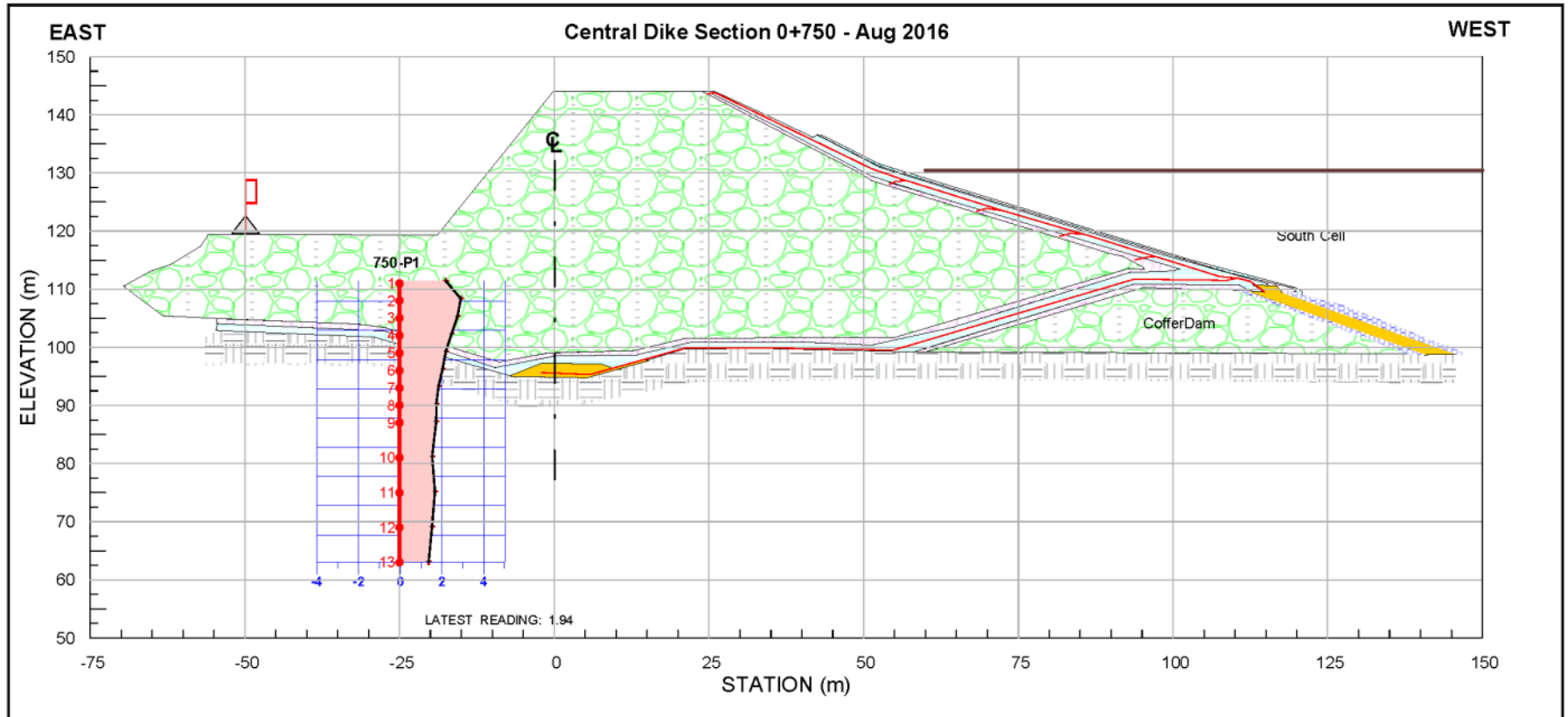
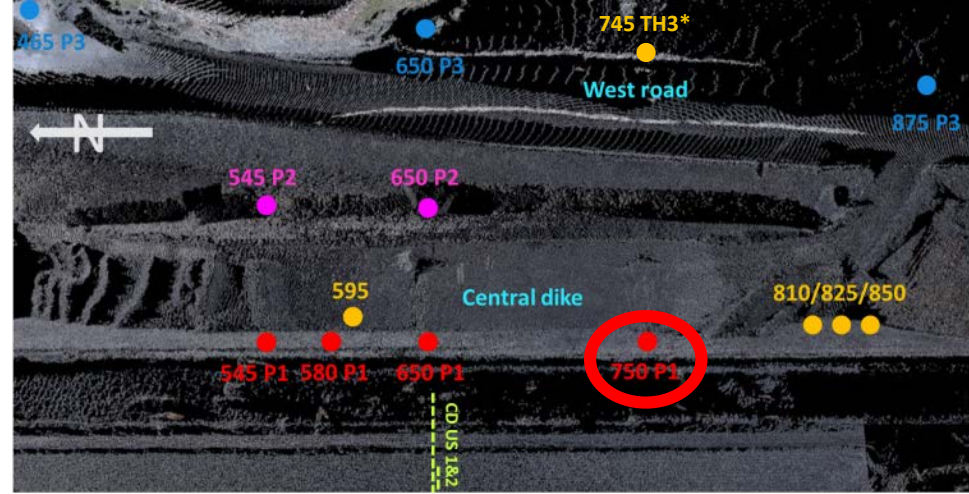

INSTRUMENTATION RESULTS



AGNICO EAGLE

Thermistors 750 P1

FULL YEAR

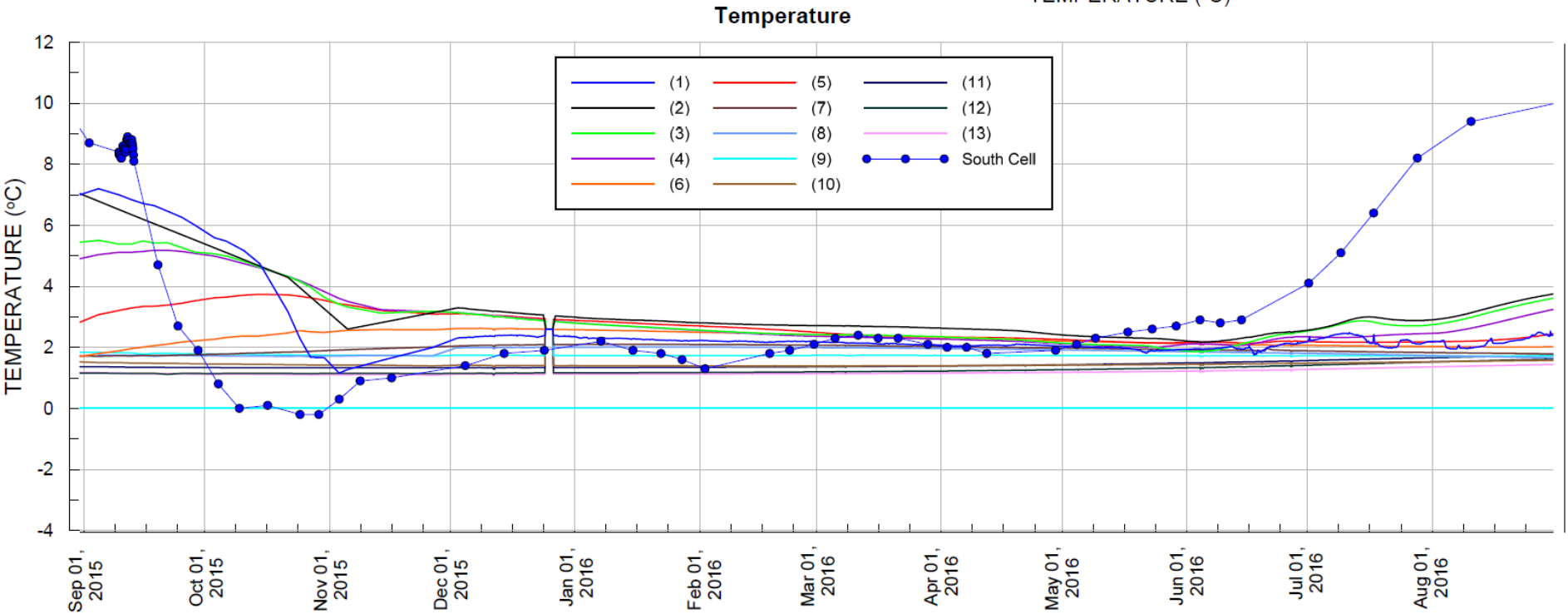
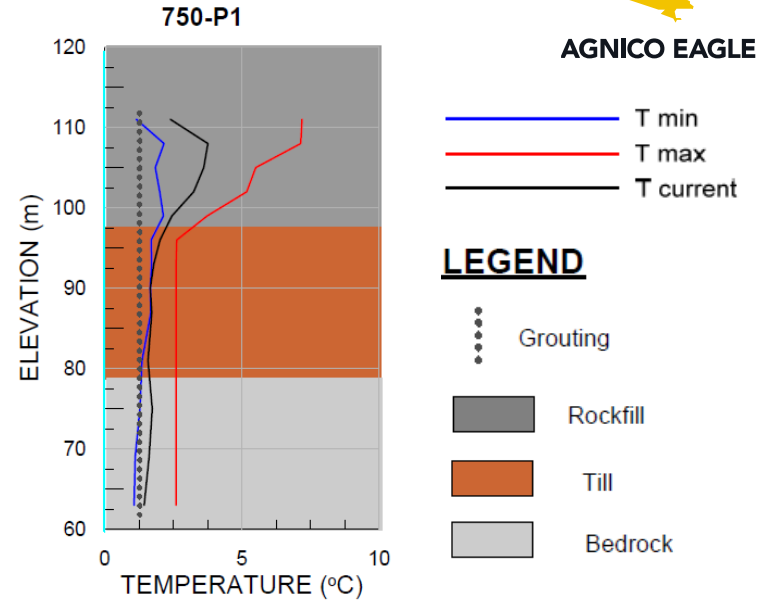

INSTRUMENTATION RESULTS

Piezometers 810

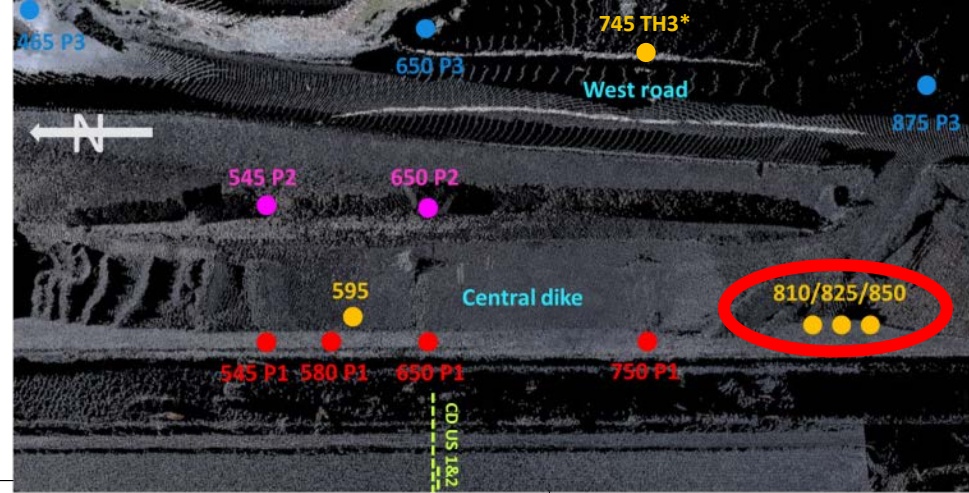

810 Hole - Piezometrics Elevation and Attenuation Pond Elevation vs Time

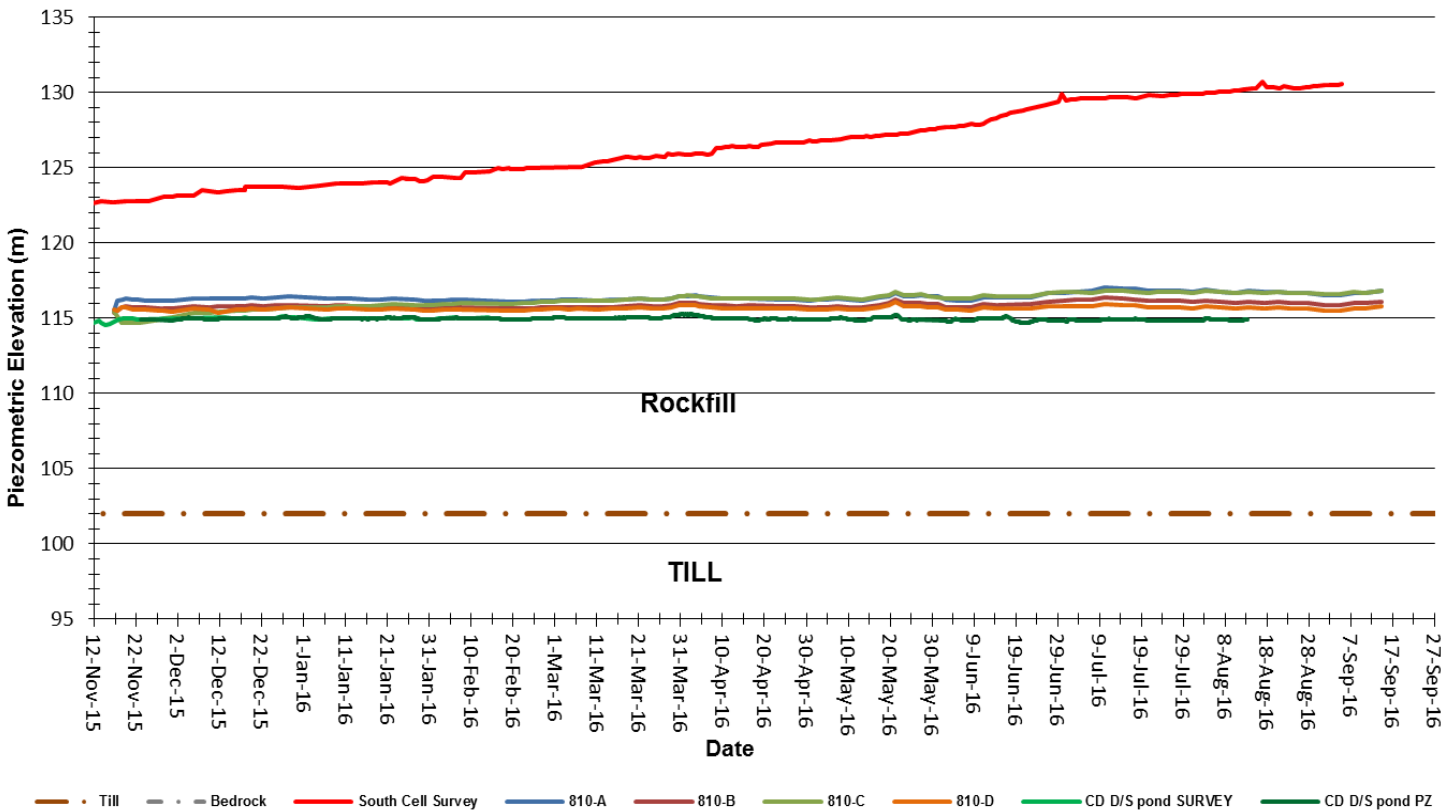

STA 810 Instrumentation

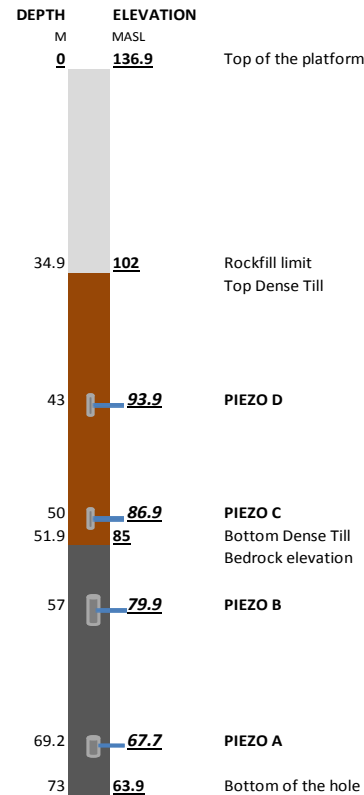

INSTRUMENTATION RESULTS

Thermistor 810

MAY 2016

Grapher

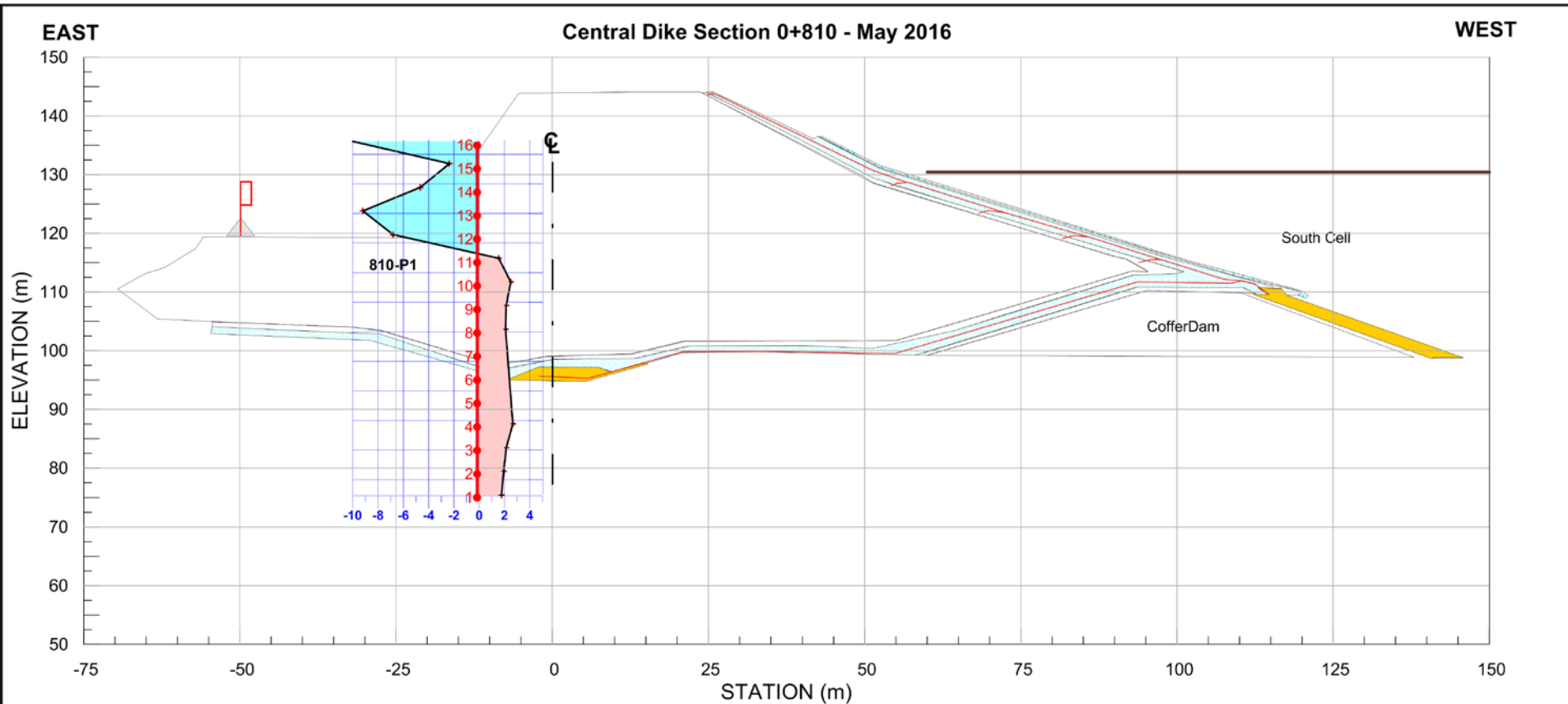
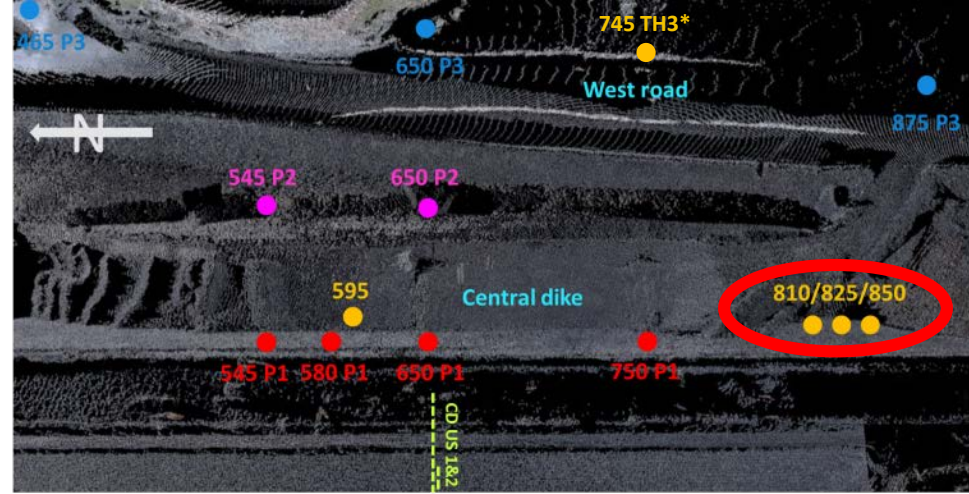

INSTRUMENTATION RESULTS

Thermistor 810

JUNE 2016

Grapher

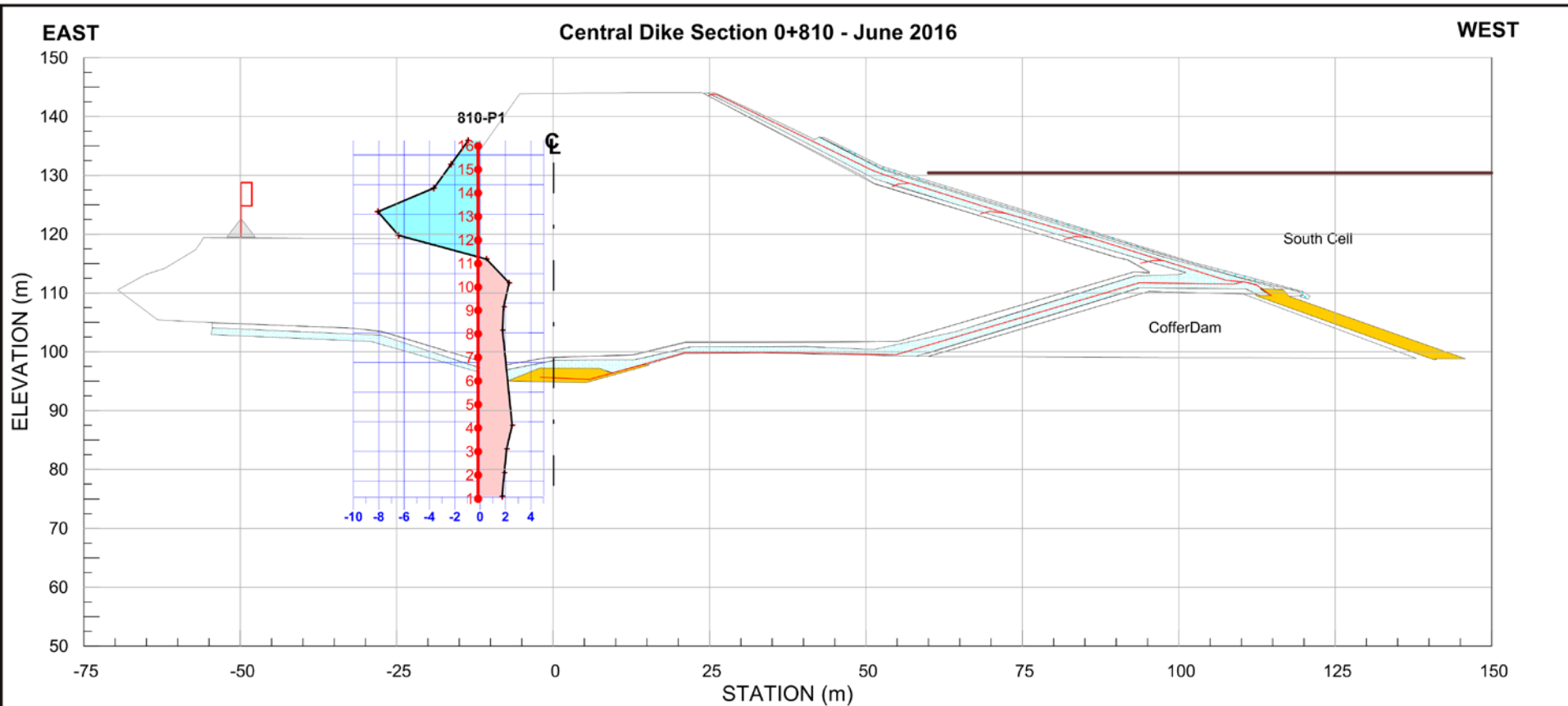
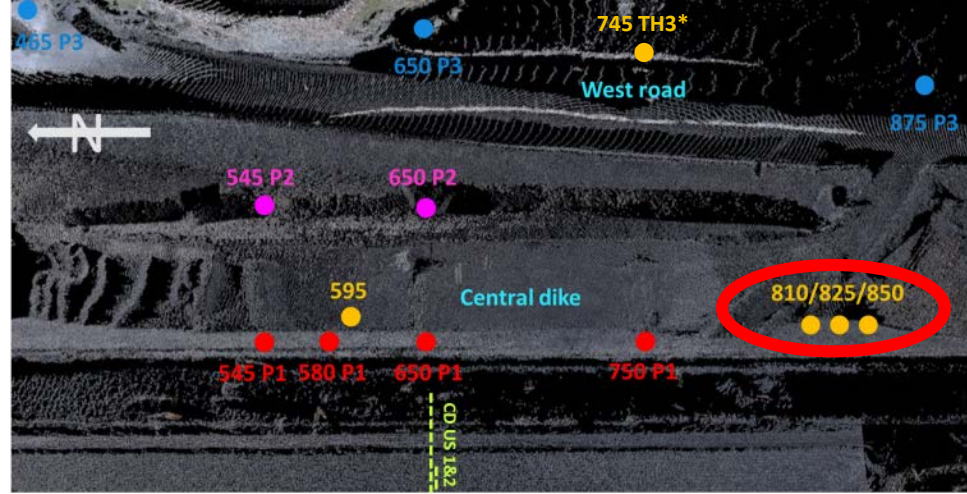

INSTRUMENTATION RESULTS

Thermistor 810

JULY 2016

Grapher

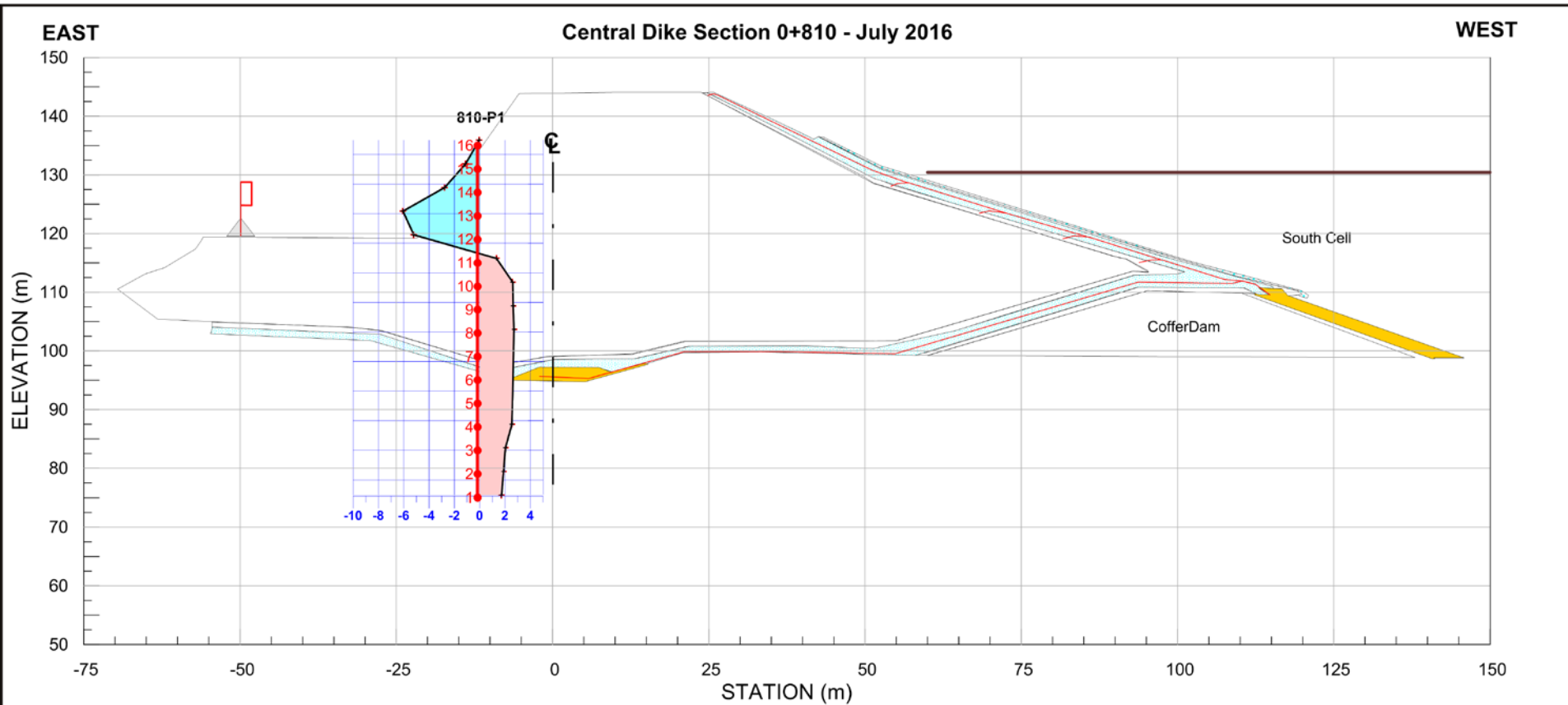
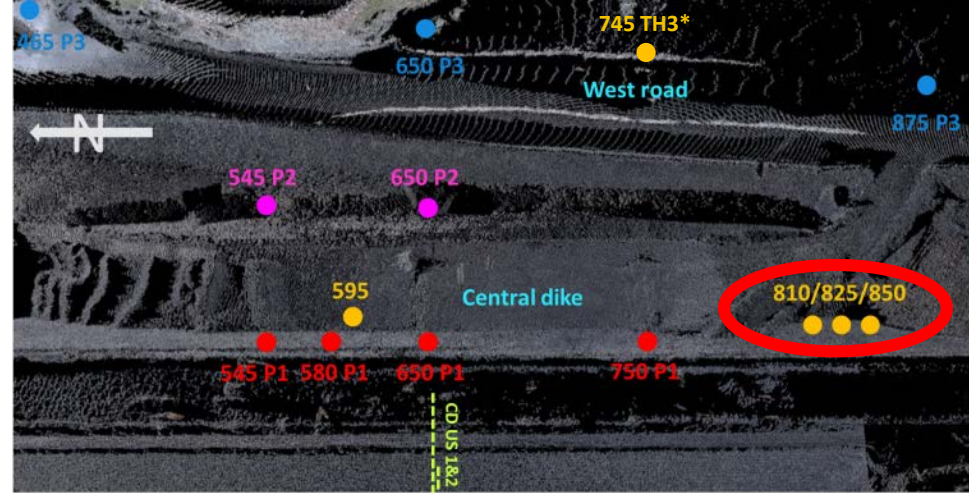

INSTRUMENTATION RESULTS

Thermistor 810

AUGUST 2016

Grapher

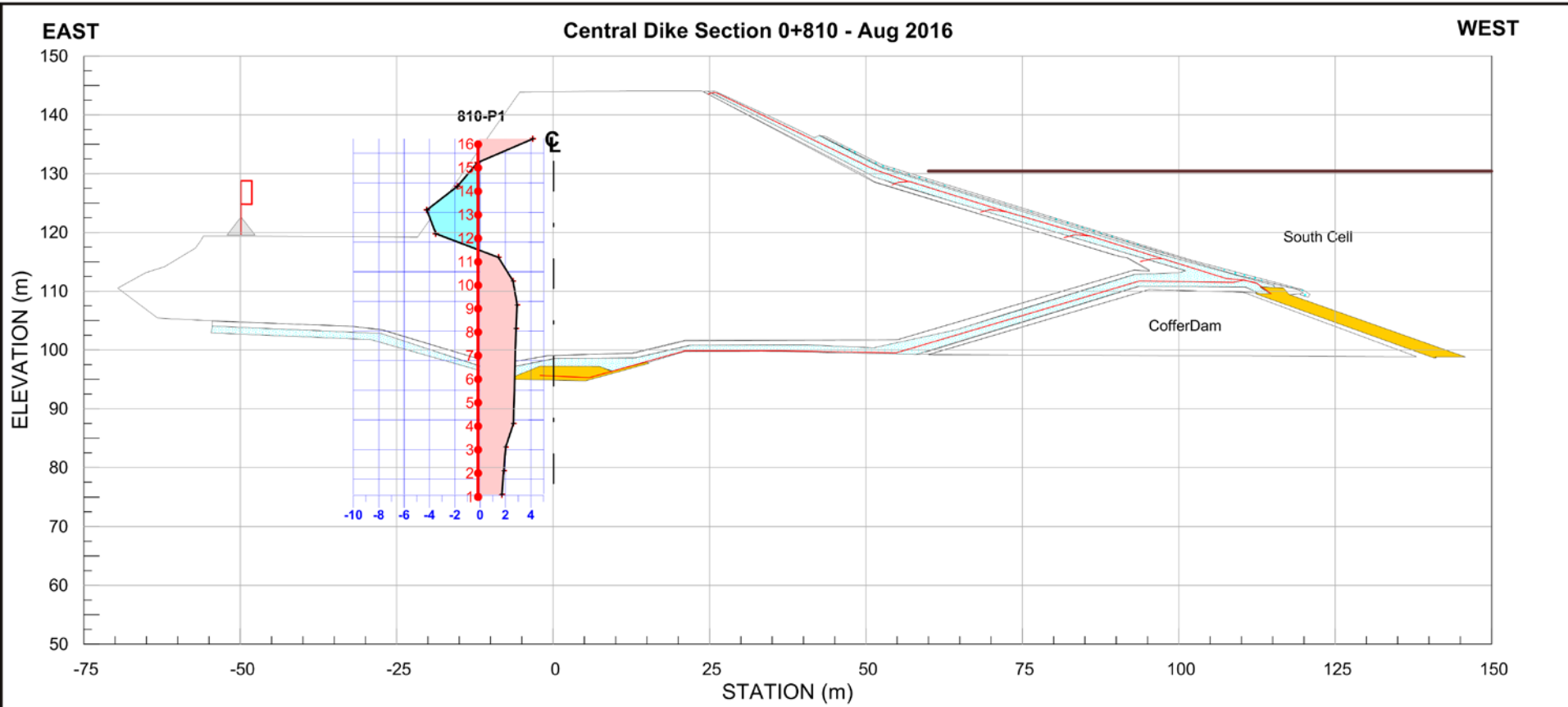
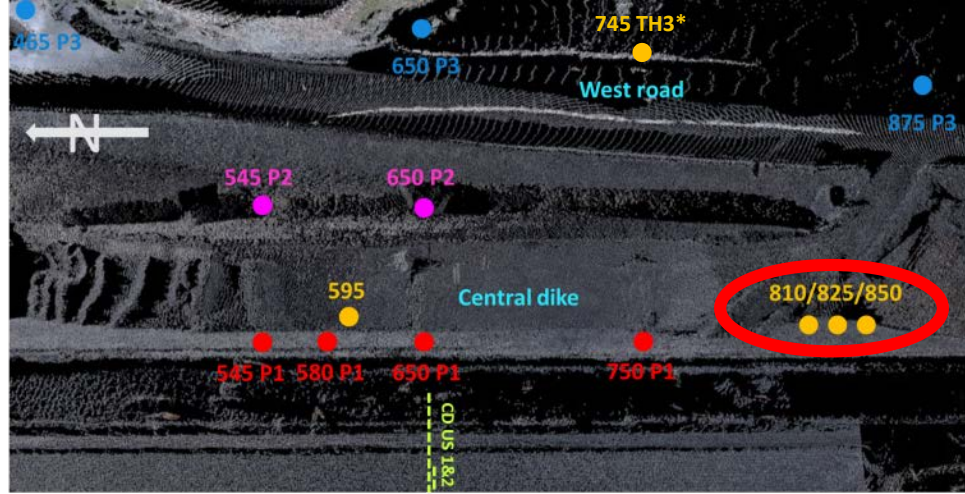

INSTRUMENTATION RESULTS

Thermistor 810

FULL YEAR



AGNICO EAGLE

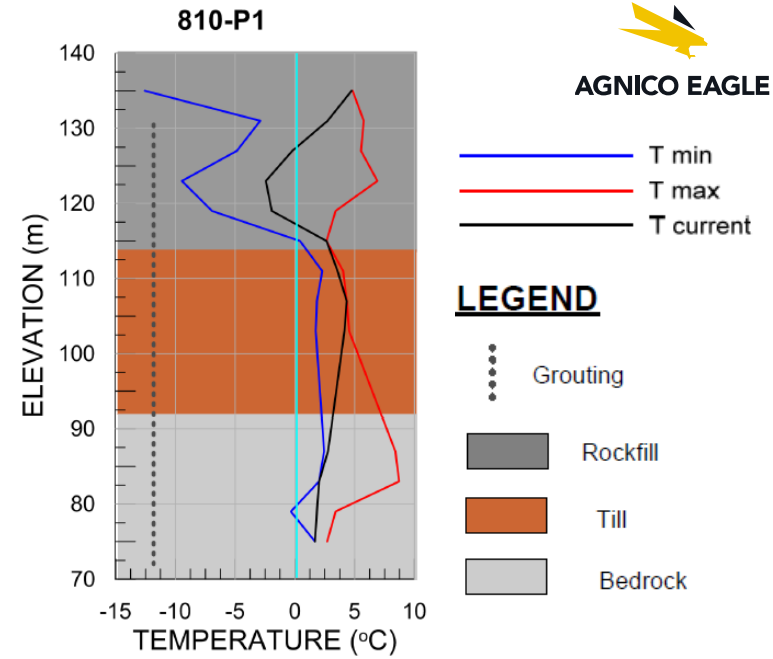

Temperature

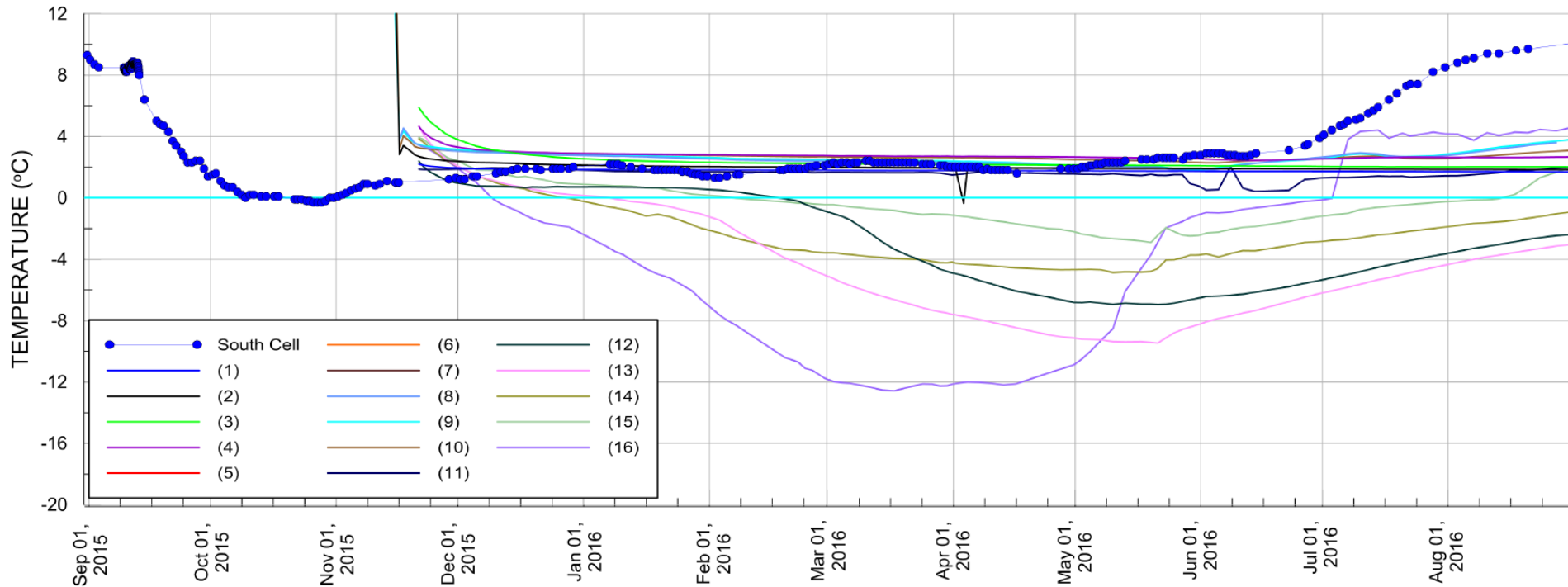

INSTRUMENTATION RESULTS

Piezometers 825

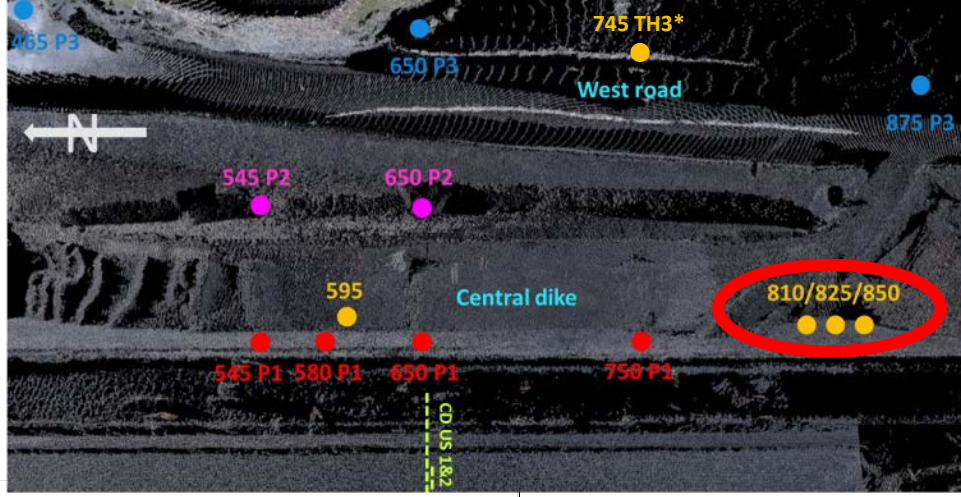

825 Hole - Piezometrics Elevation and Attenuation Pond Elevation vs Time

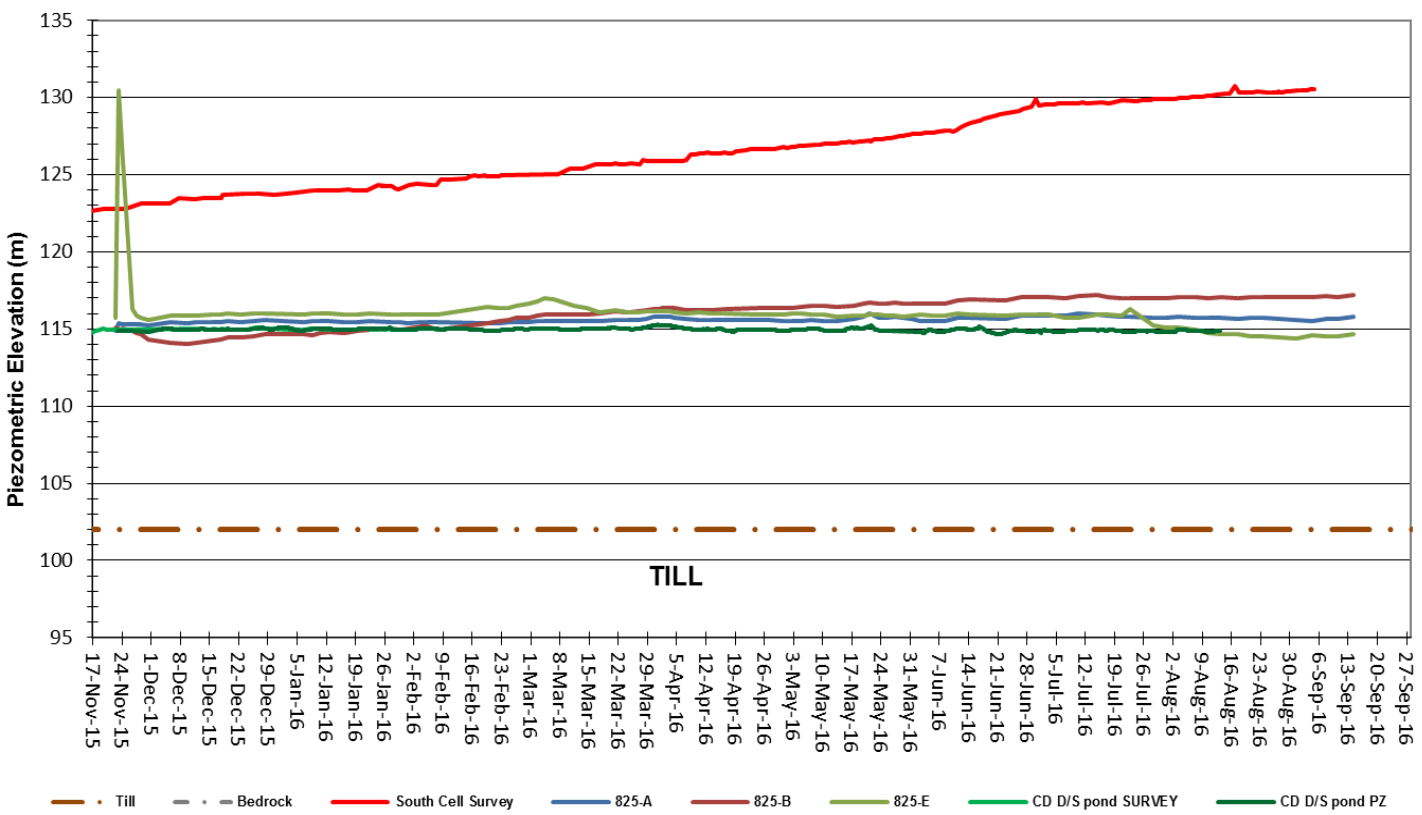

STA 825 Instrumentation

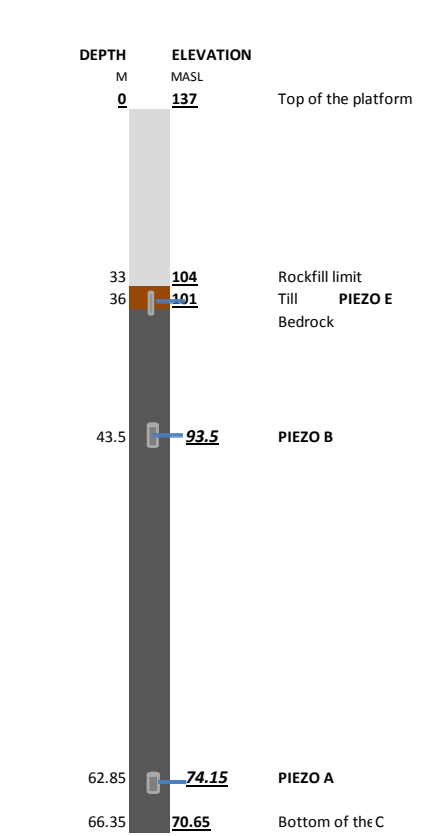

INSTRUMENTATION RESULTS

Thermistor 825

MAY 2016

Grapher

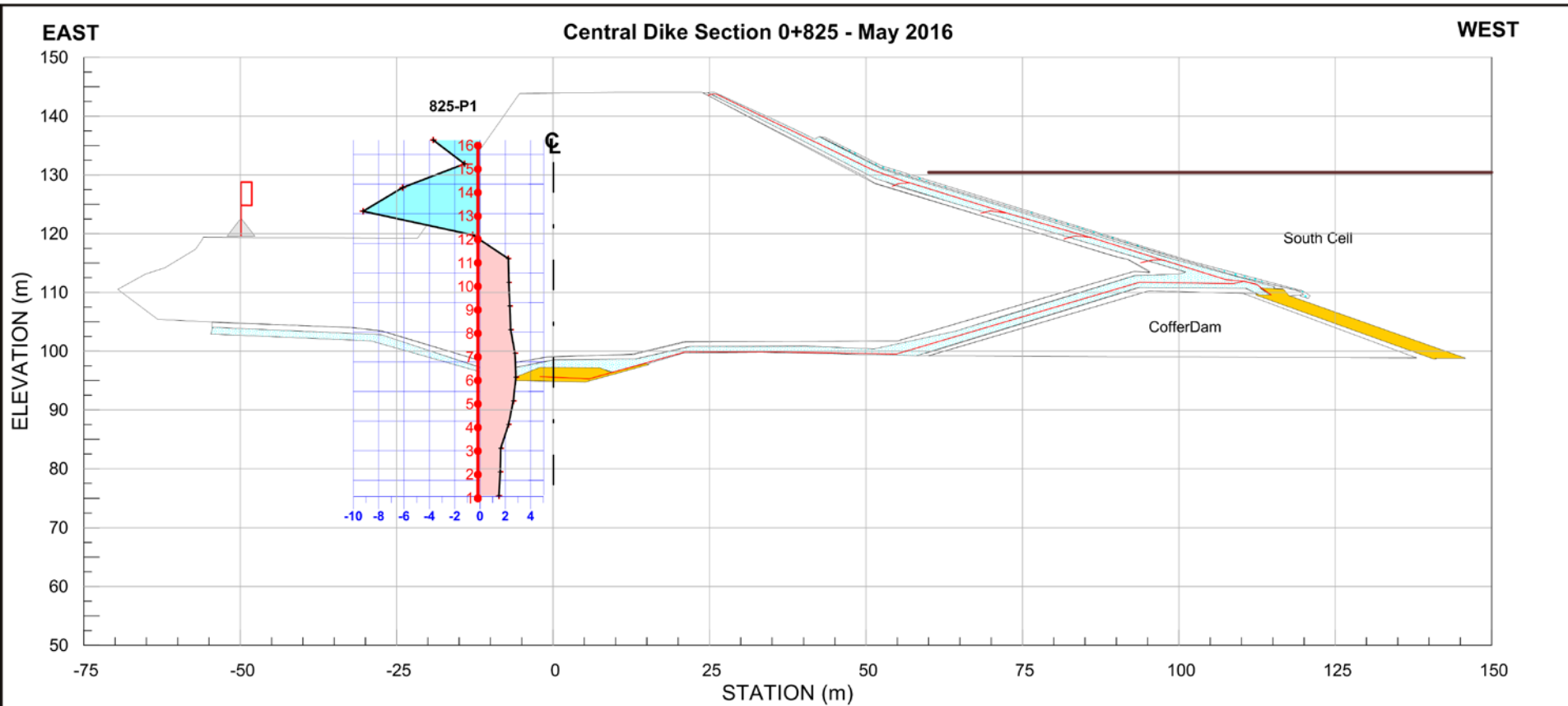
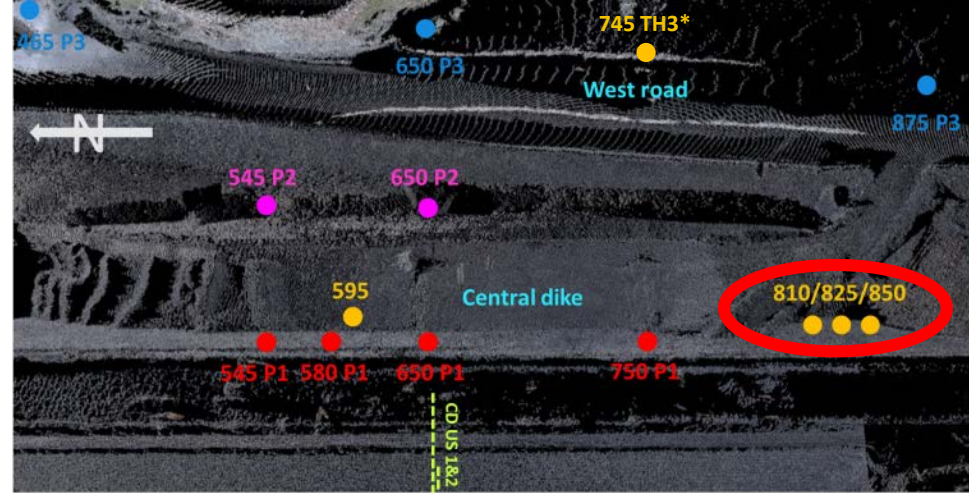

INSTRUMENTATION RESULTS

Thermistor 825

JUNE 2016

Grapher

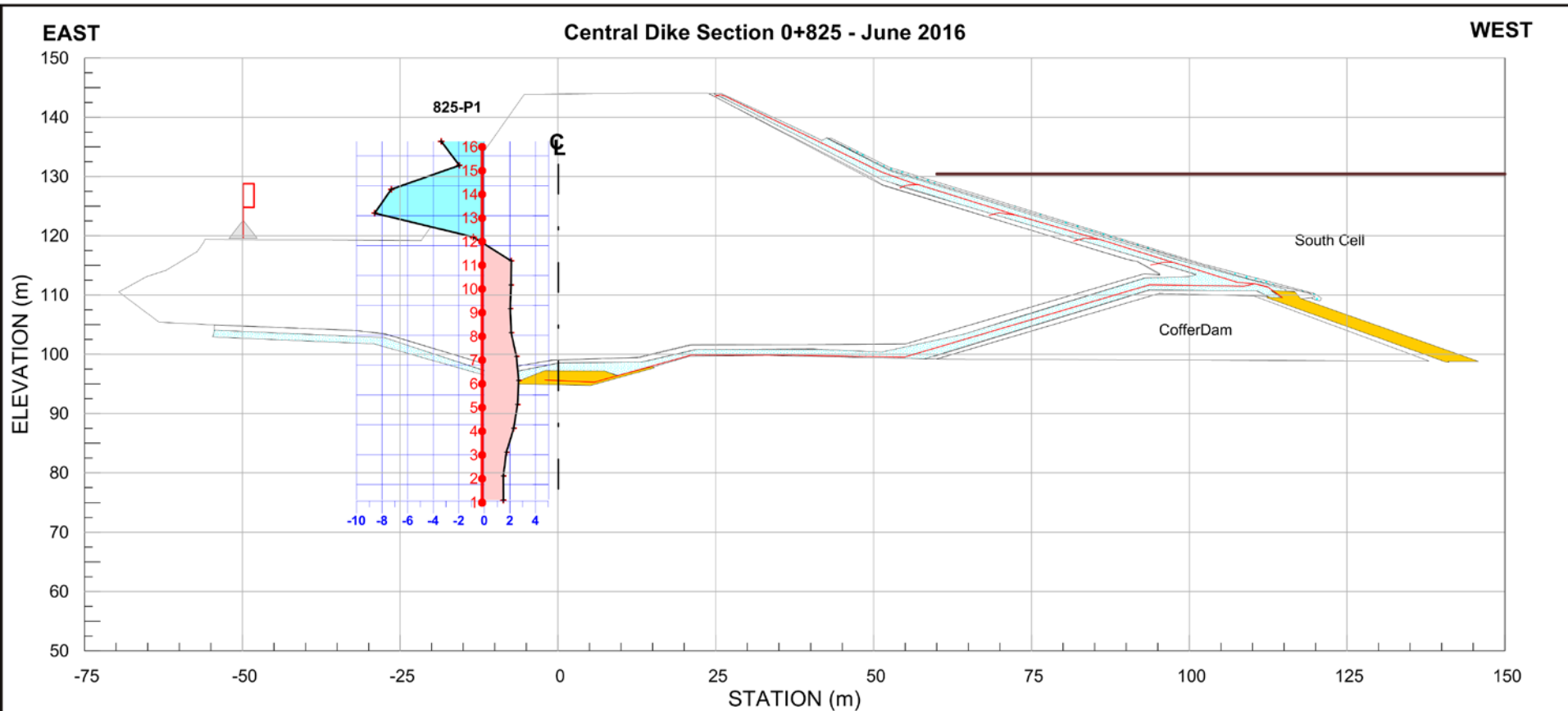
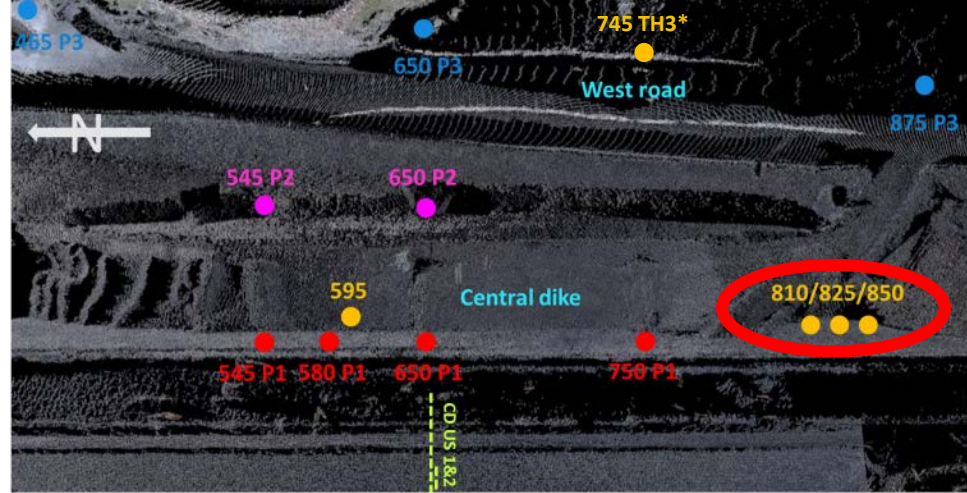

INSTRUMENTATION RESULTS

Thermistor 825

JULY 2016

Grapher

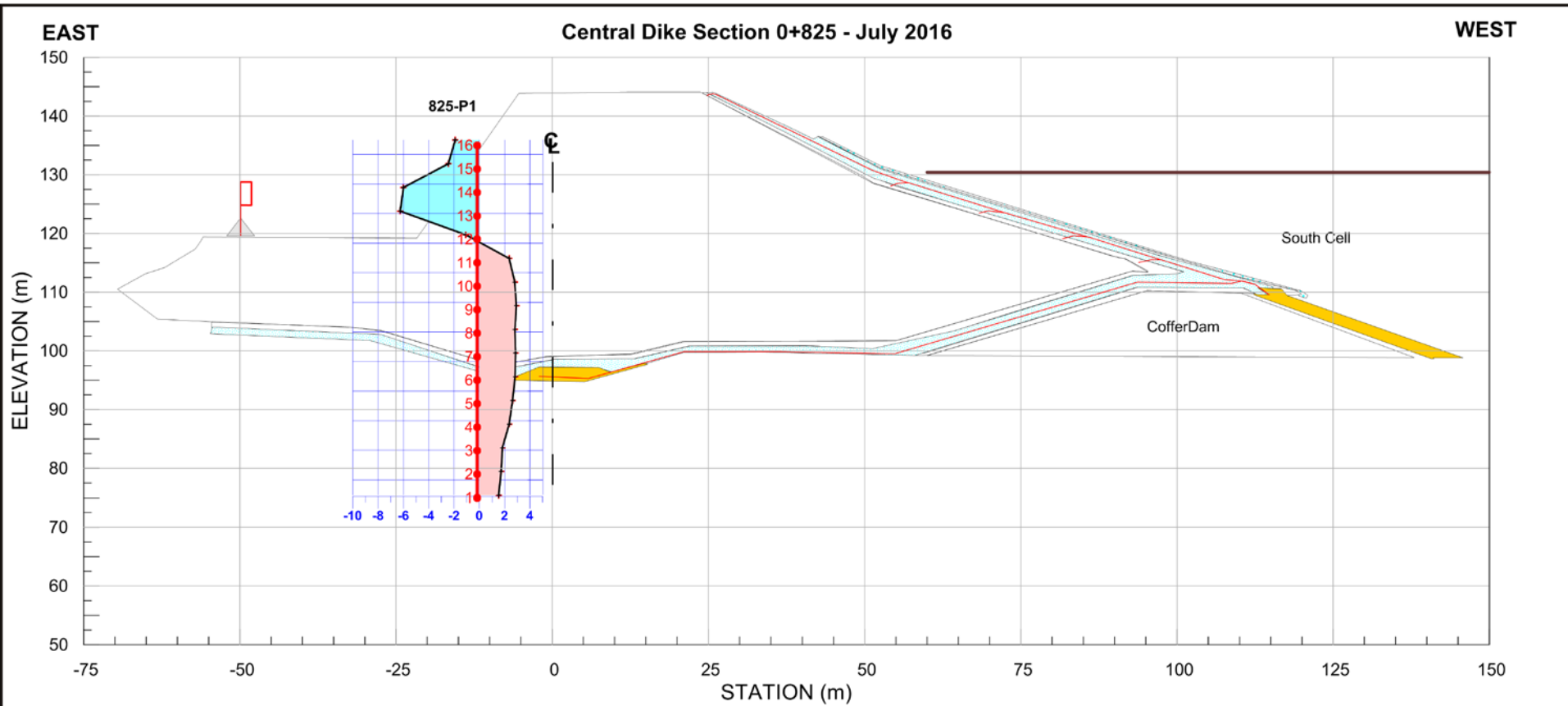
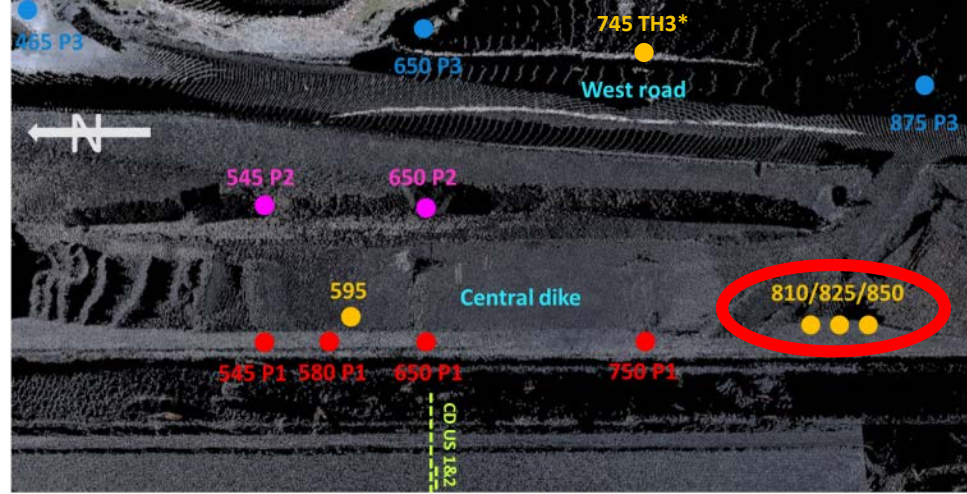

INSTRUMENTATION RESULTS

Thermistor 825

AUGUST 2016

Grapher

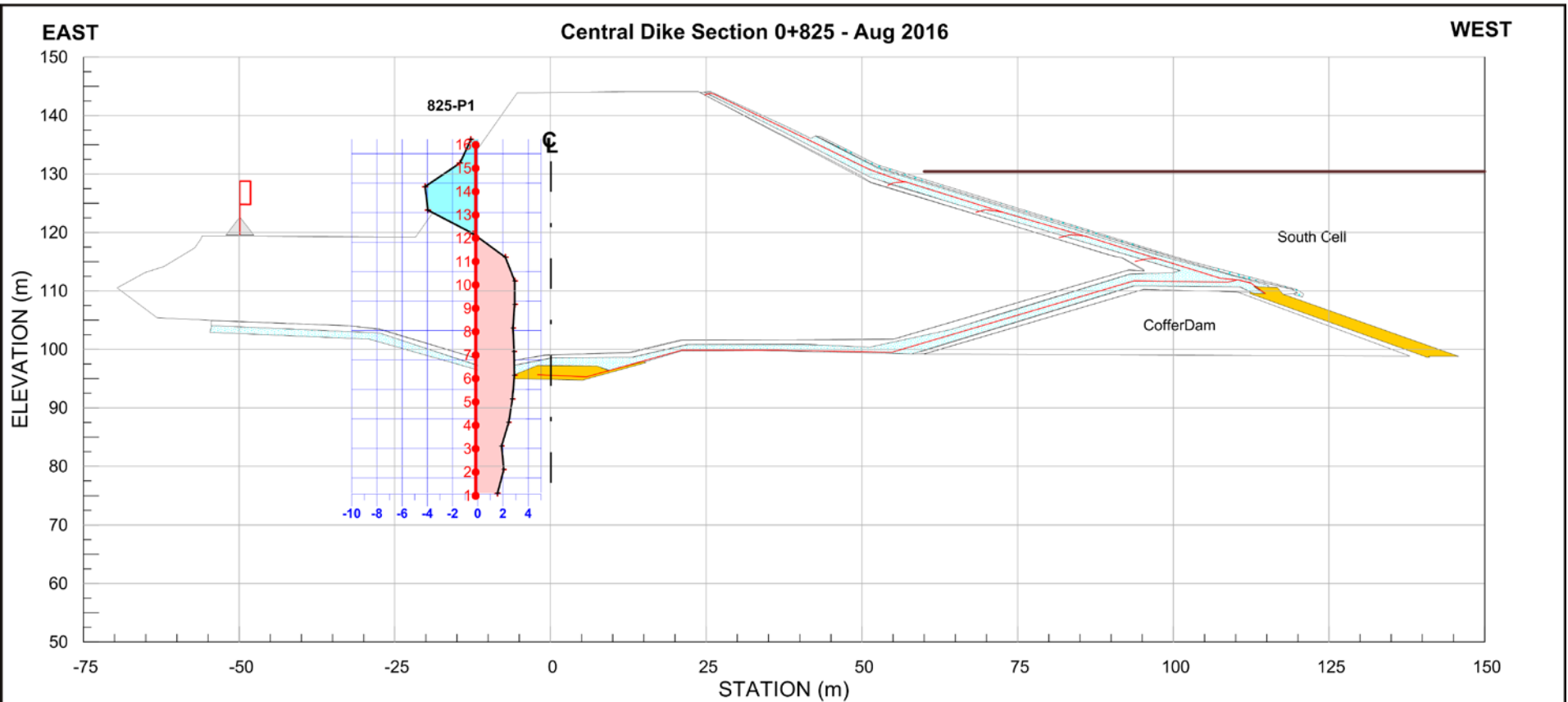
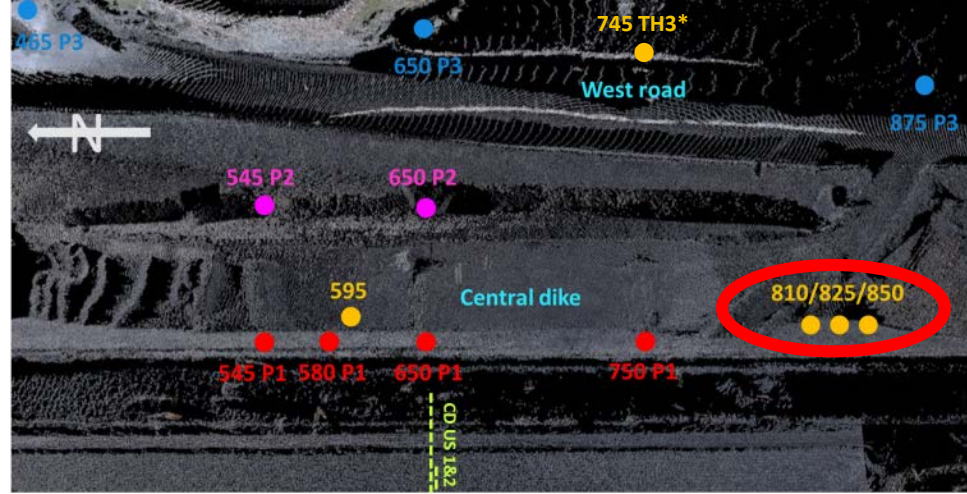

INSTRUMENTATION RESULTS

Thermistor 825

FULL YEAR



AGNICO EAGLE

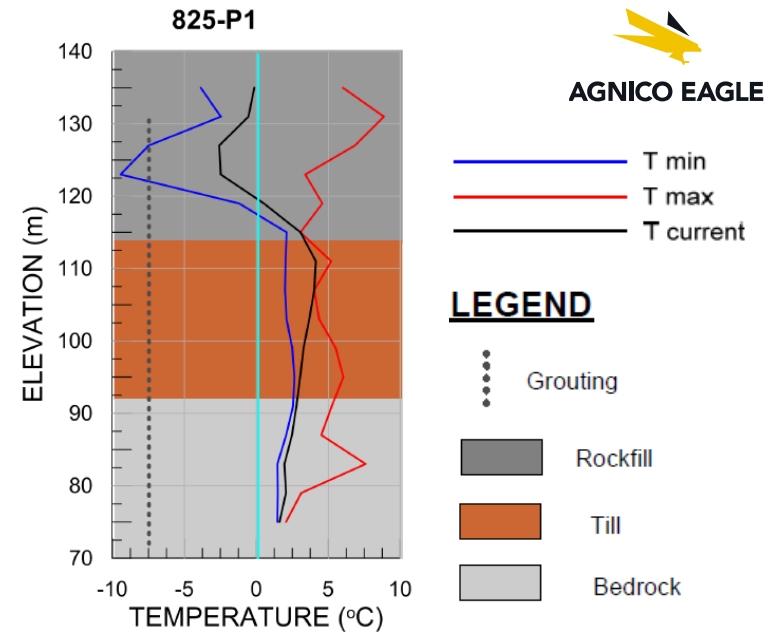

Temperature

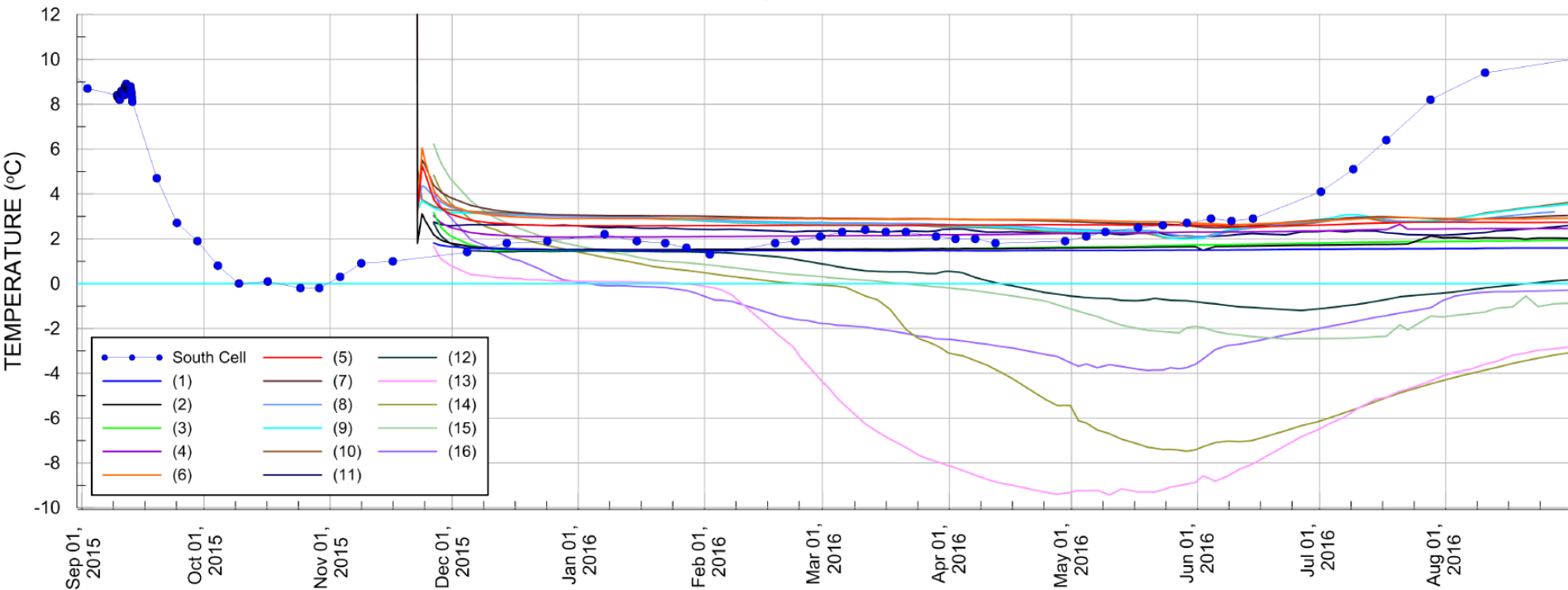

INSTRUMENTATION RESULTS

Piezometers 850

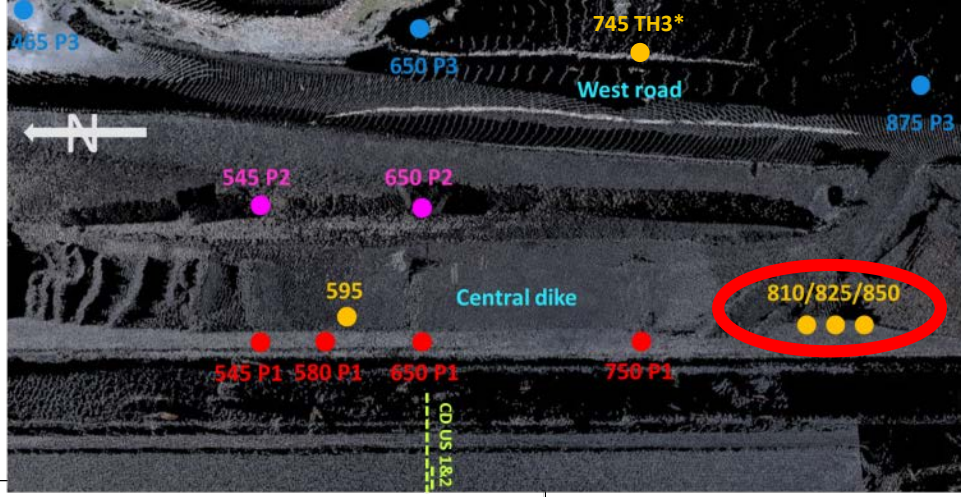

850 Hole - Piezometrics Elevation and Attenuation Pond Elevation vs Time

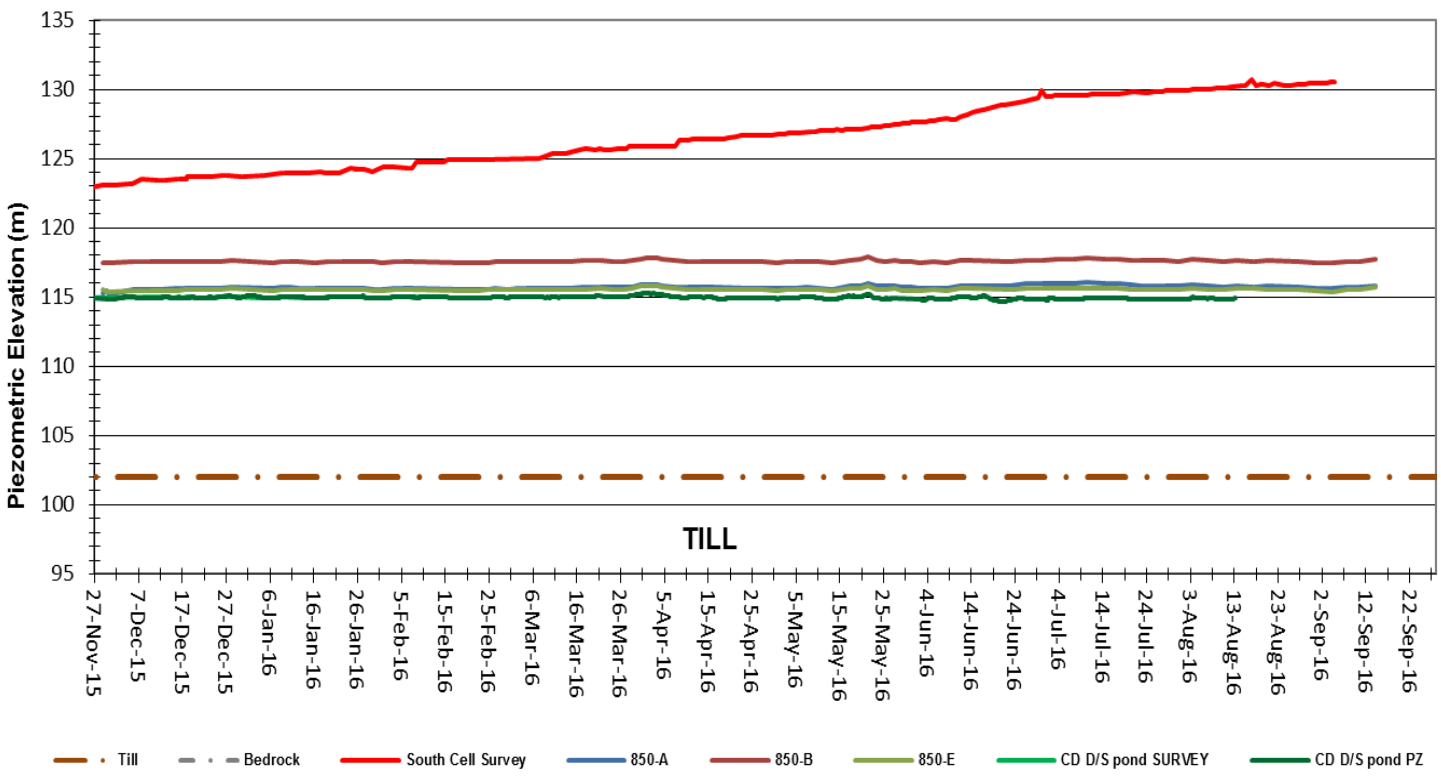

STA 850 Instrumentation

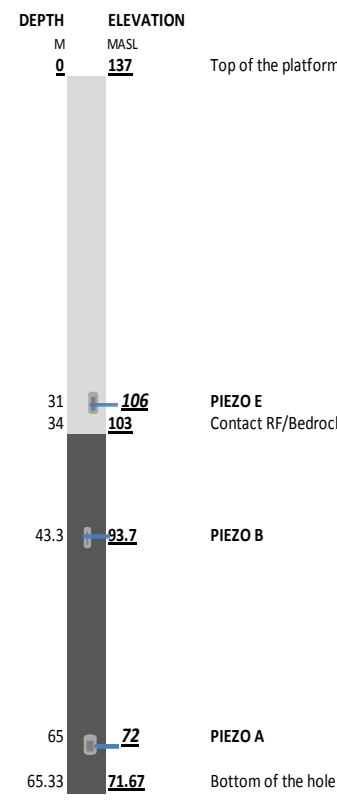

INSTRUMENTATION RESULTS

Thermistor 850

MAY 2016

Grapher

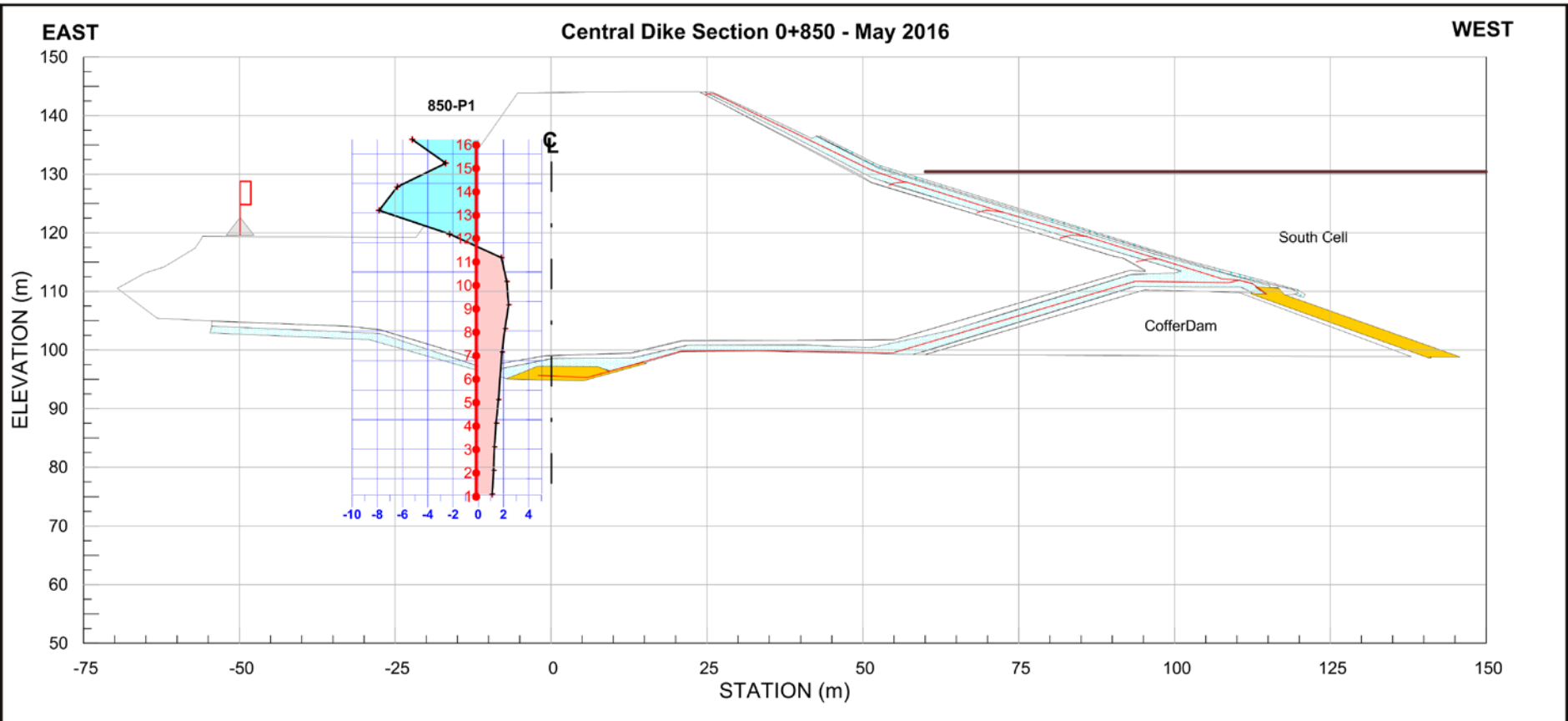
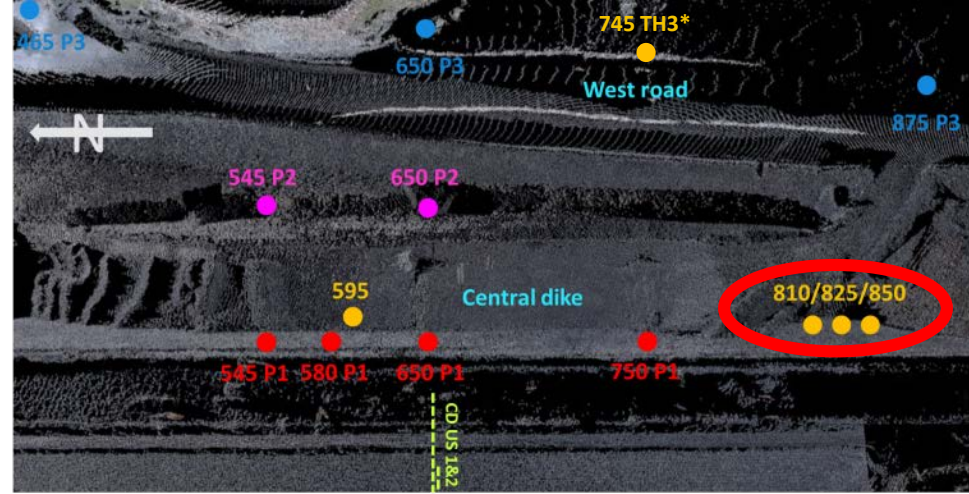

INSTRUMENTATION RESULTS

Thermistor 850

JUNE 2016

Grapher

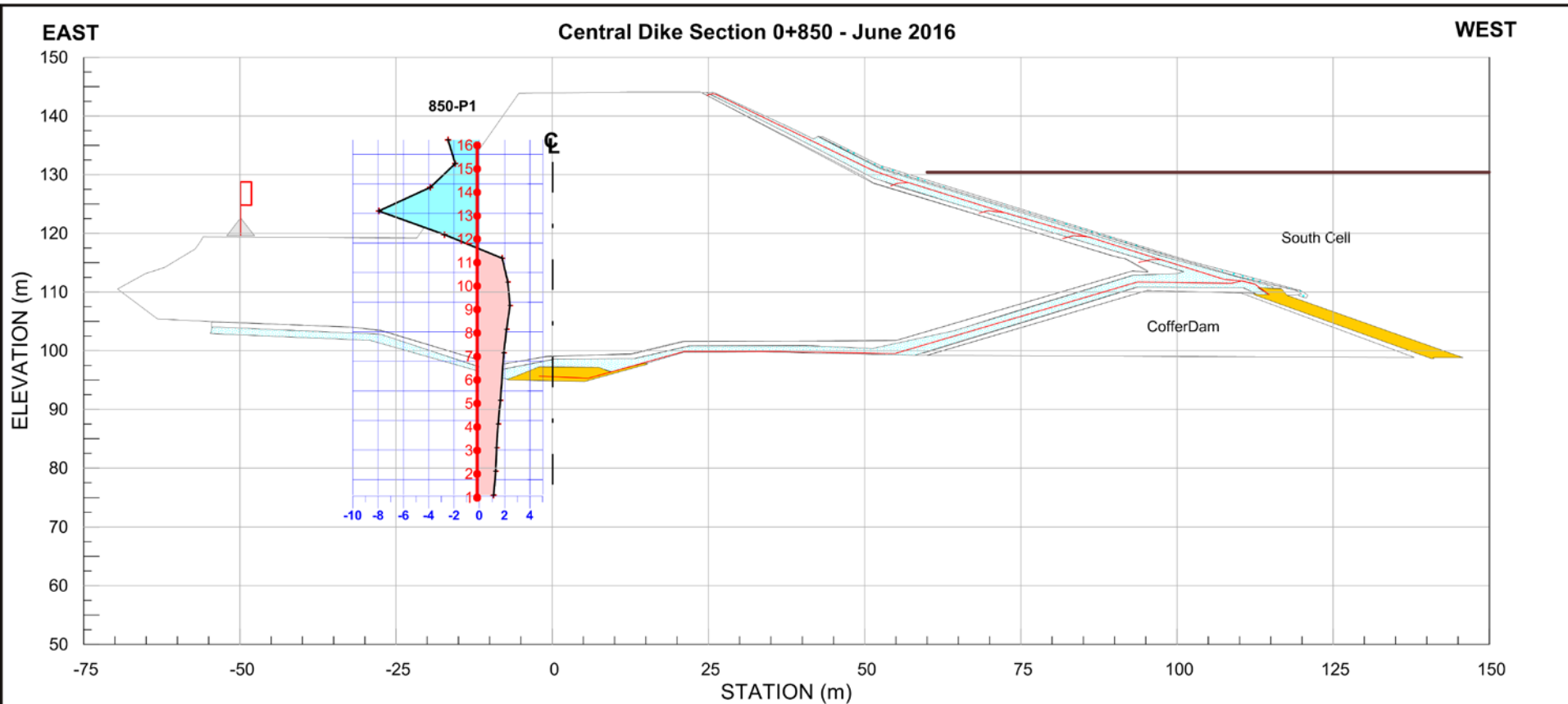
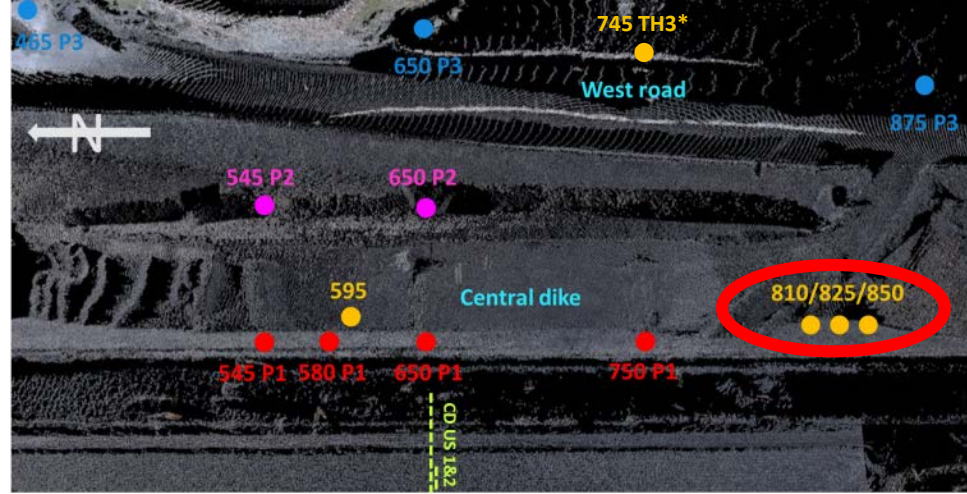

INSTRUMENTATION RESULTS

Thermistor 850

JULY 2016

Grapher

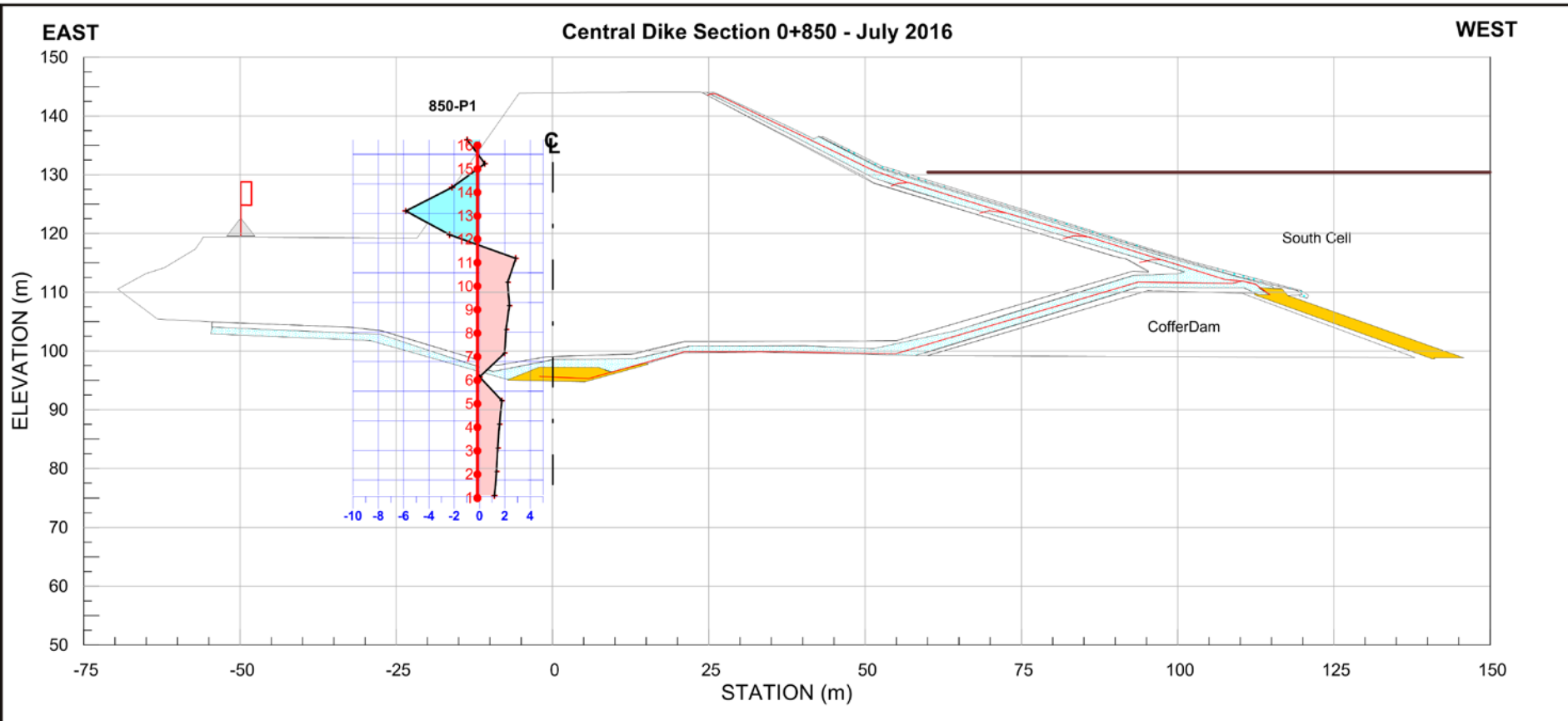
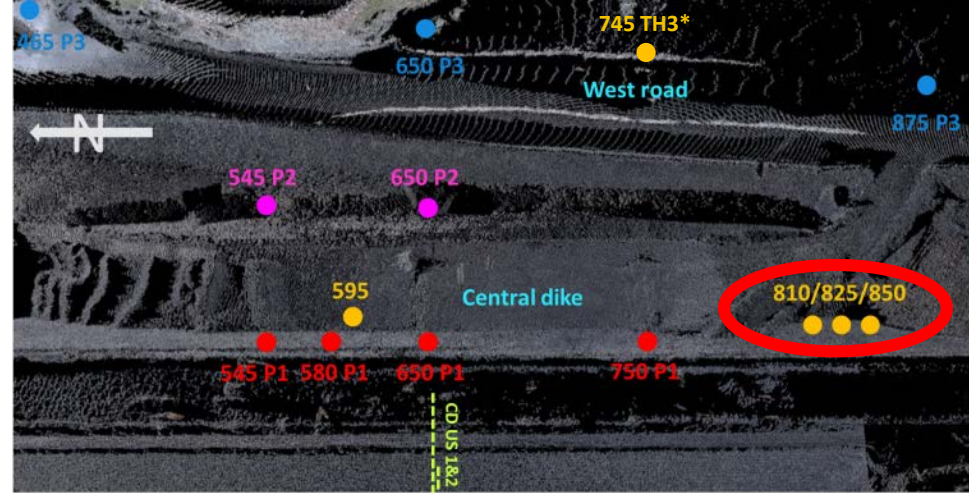

INSTRUMENTATION RESULTS

Thermistor 850

AUGUST 2016

Grapher

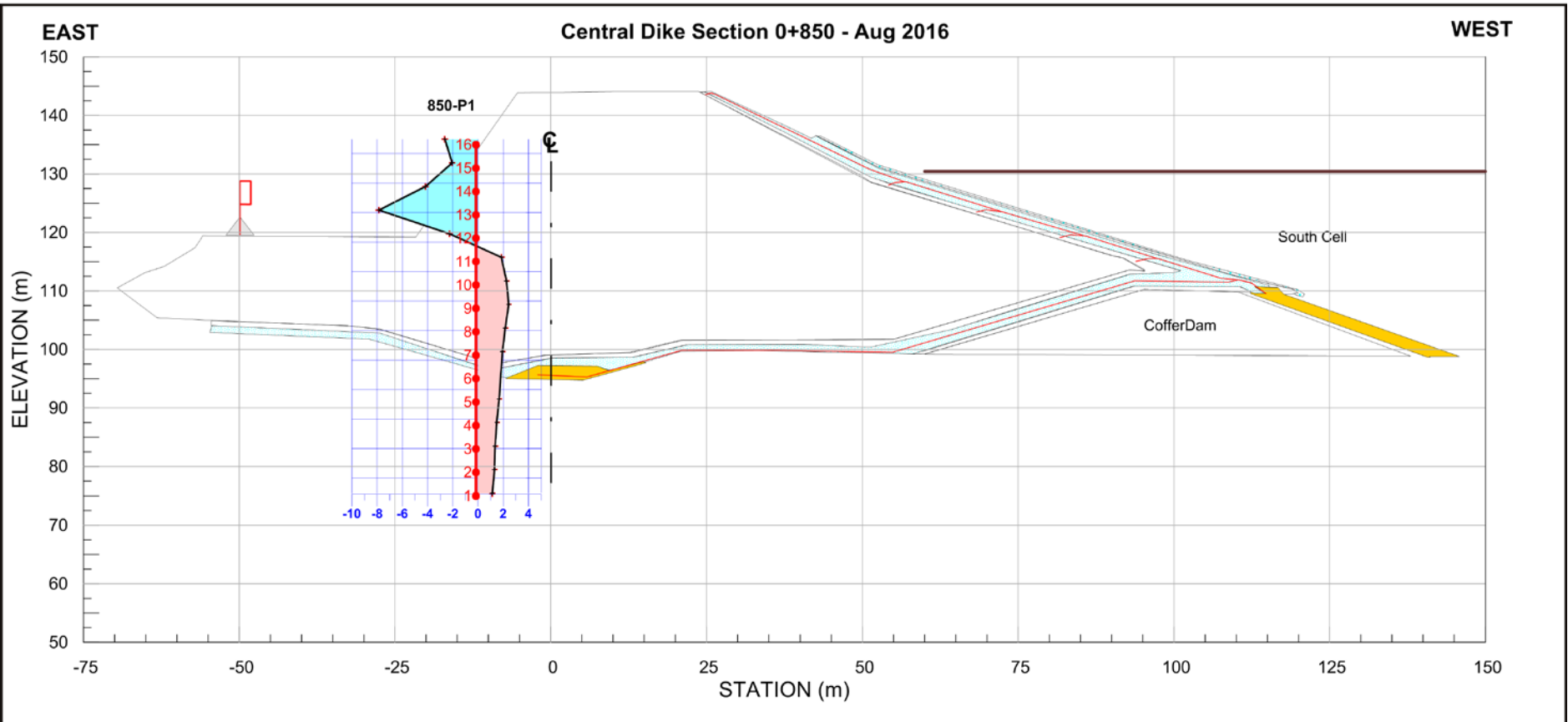
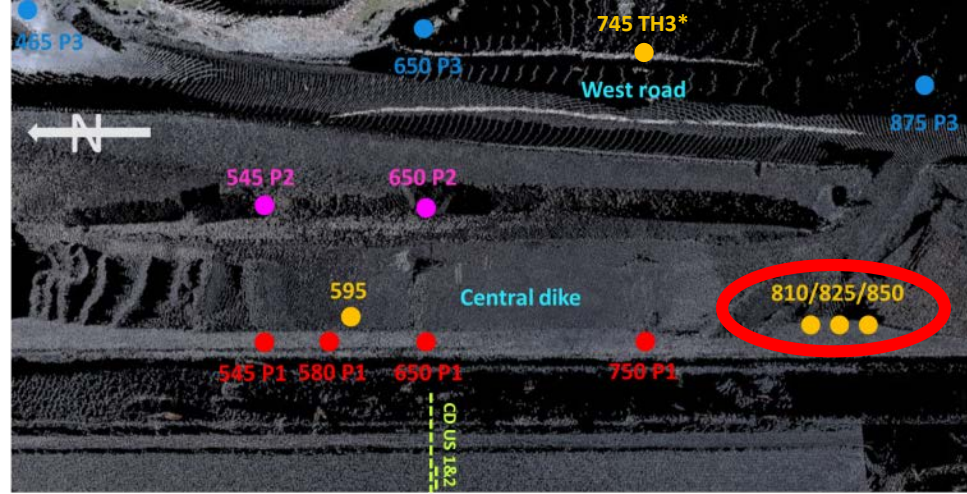

INSTRUMENTATION RESULTS

Thermistor 850

FULL YEAR



AGNICO EAGLE

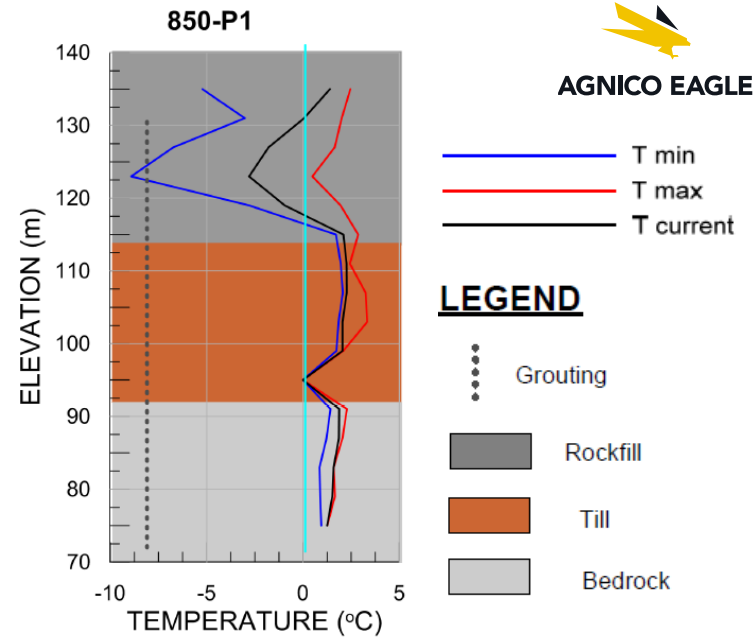

Temperature

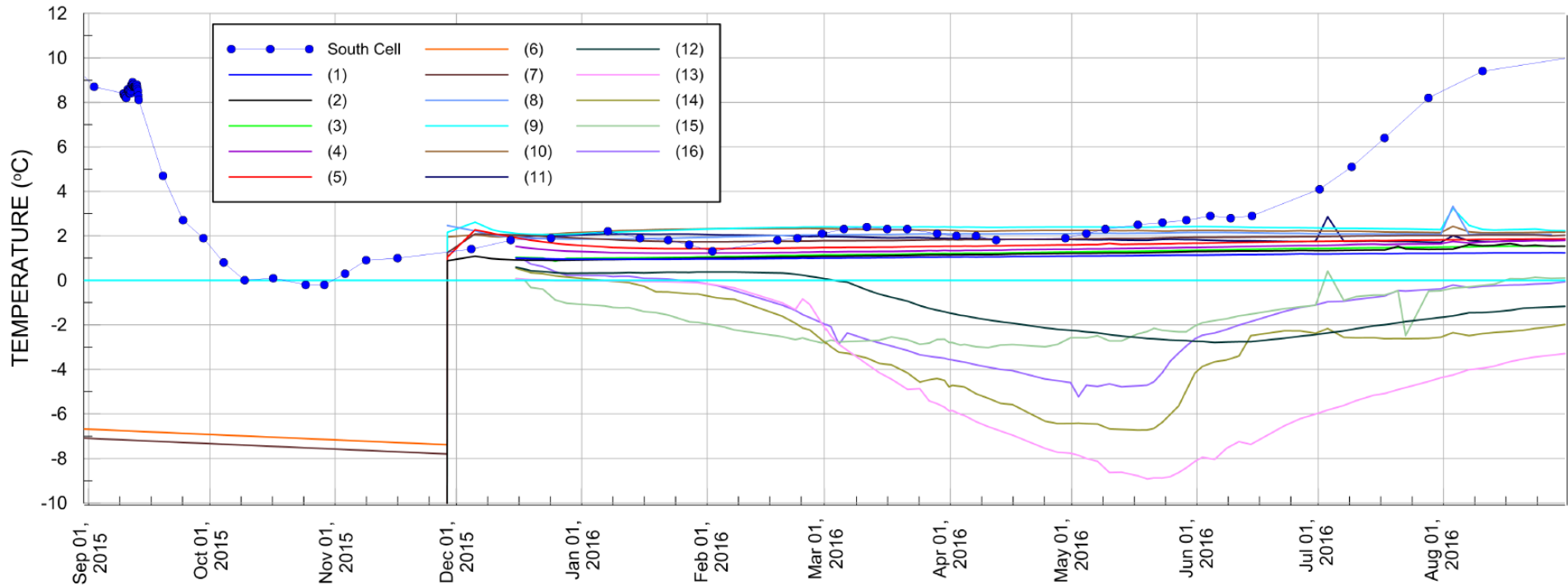

INSTRUMENTATION RESULTS

Piezometers 875 P3

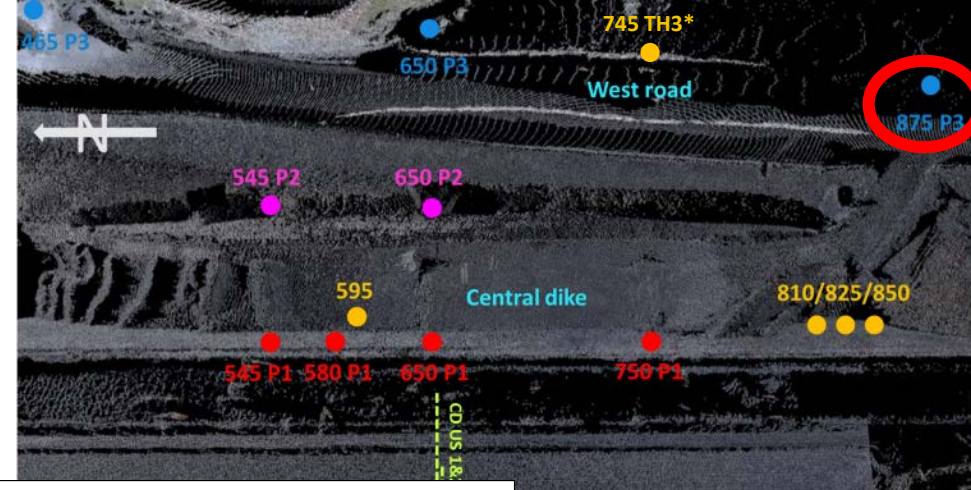

875-P3 Hole - Piezometrics Elevation and Attenuation Pond Elevation vs Time

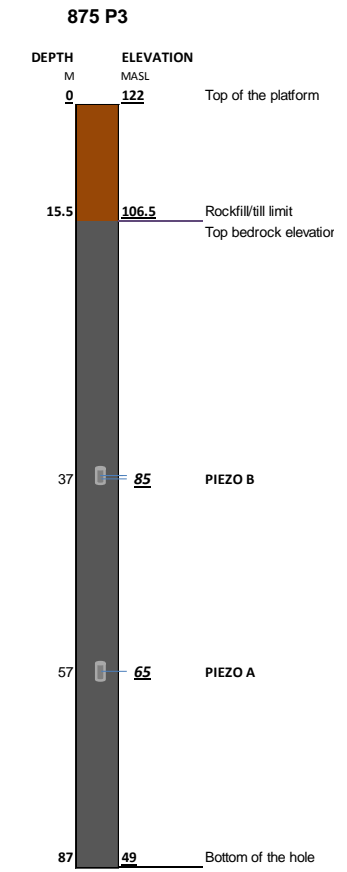
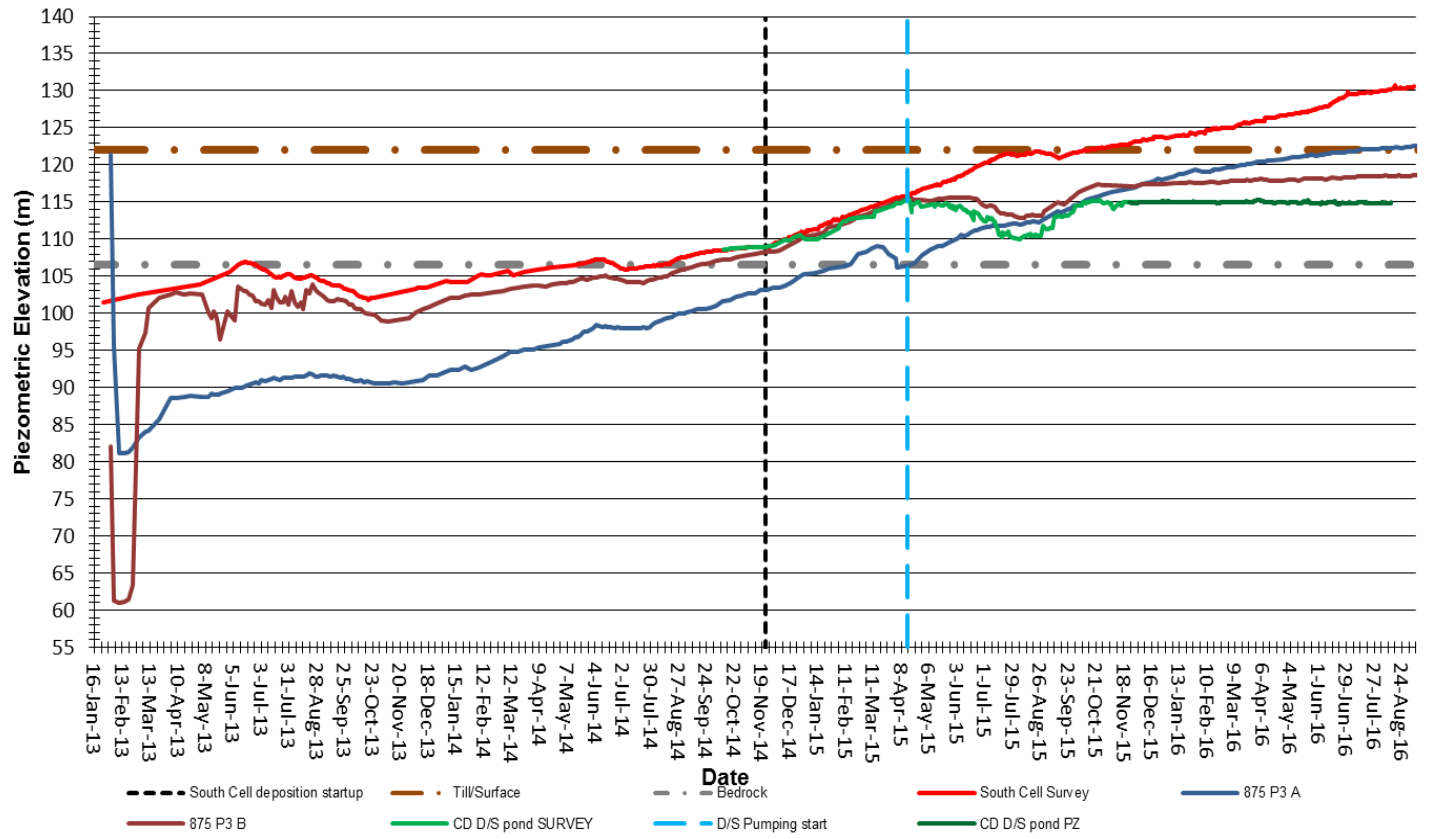

INSTRUMENTATION RESULTS

Thermistor 875 P3

MAY 2016

Grapher

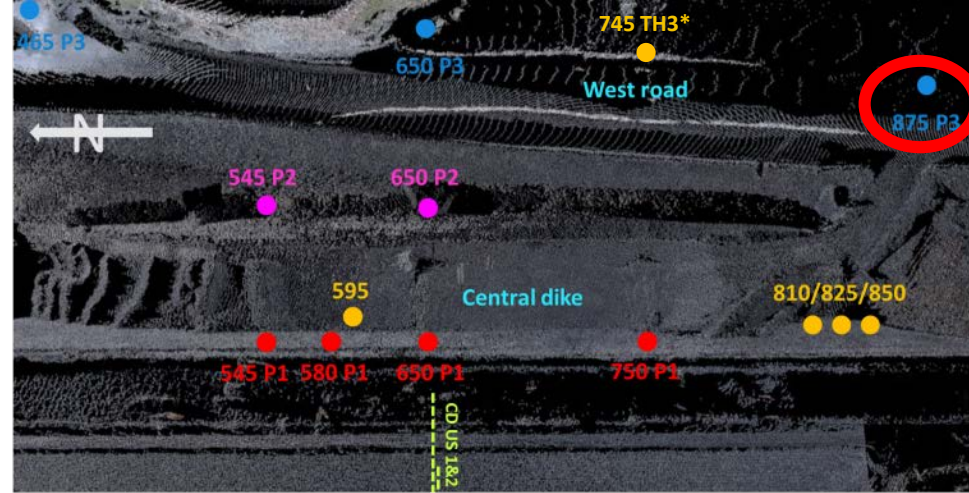

EAST

Central Dike Section 0+745 (WR P3) - May 2016

WEST

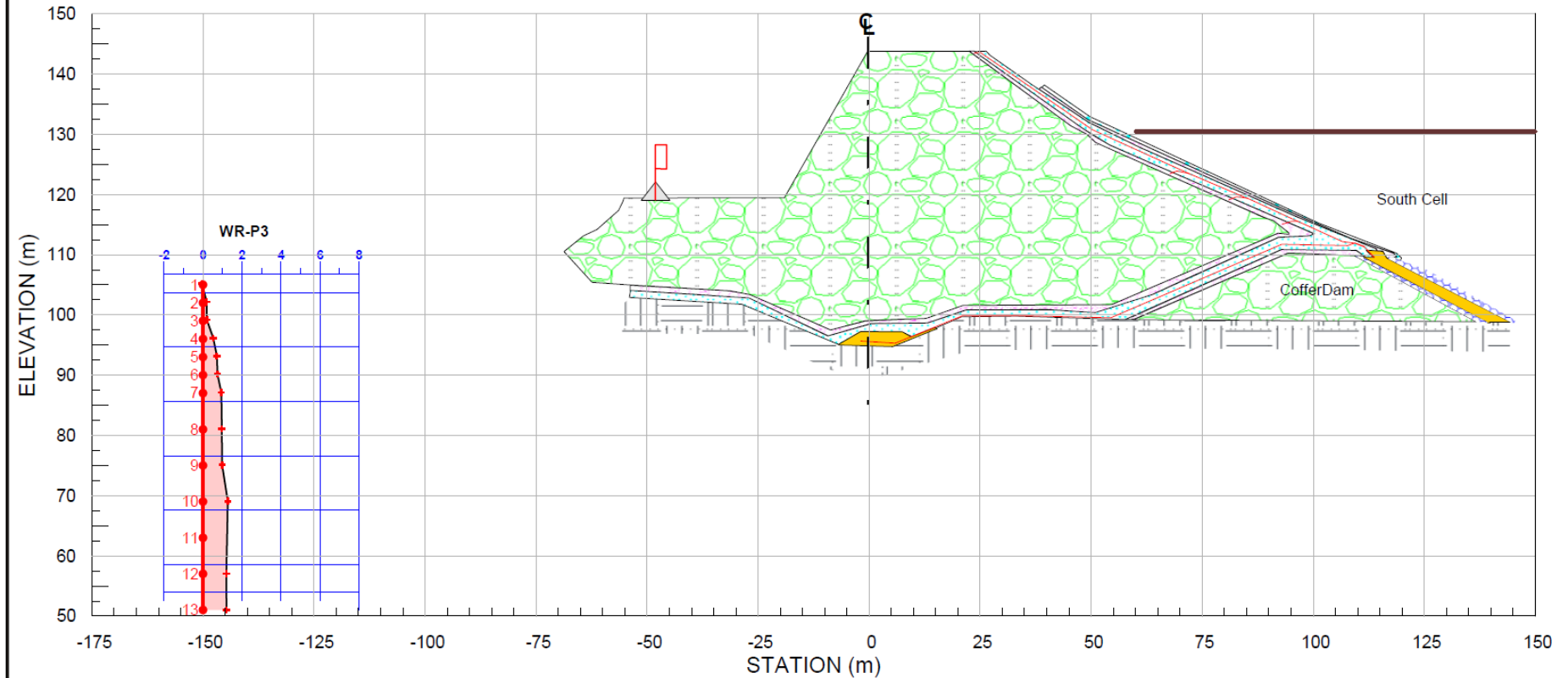

INSTRUMENTATION RESULTS

Thermistor 875 P3

JUNE 2016

Grapher

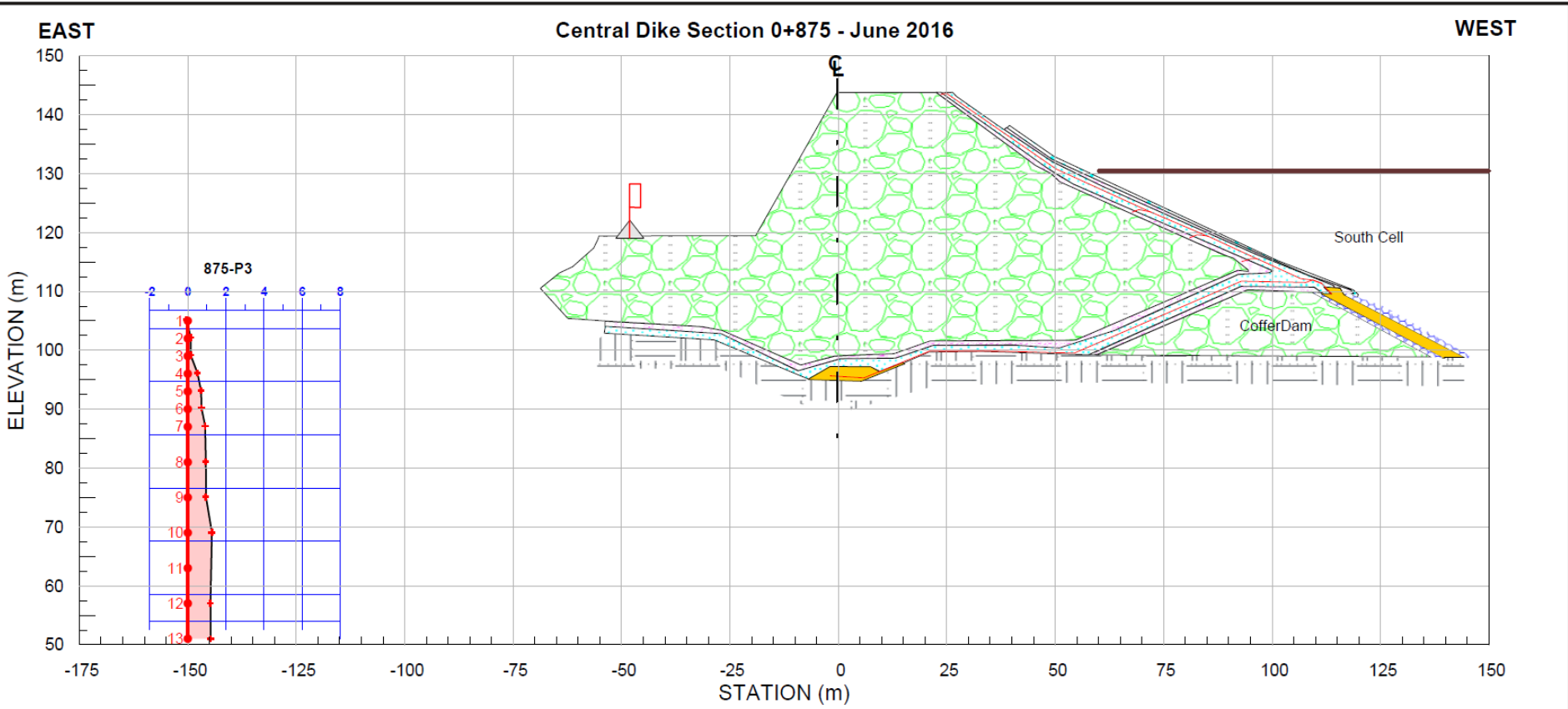
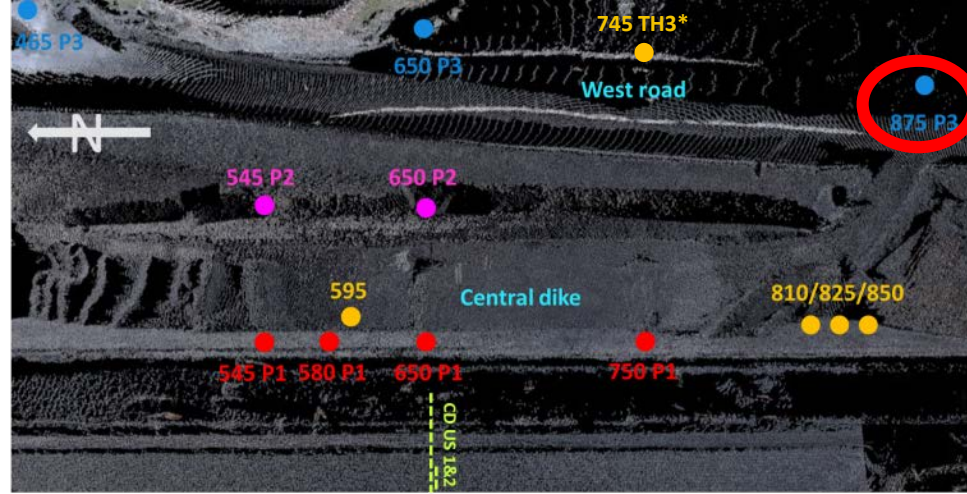

INSTRUMENTATION RESULTS

Thermistor 875 P3

JULY 2016

Grapher

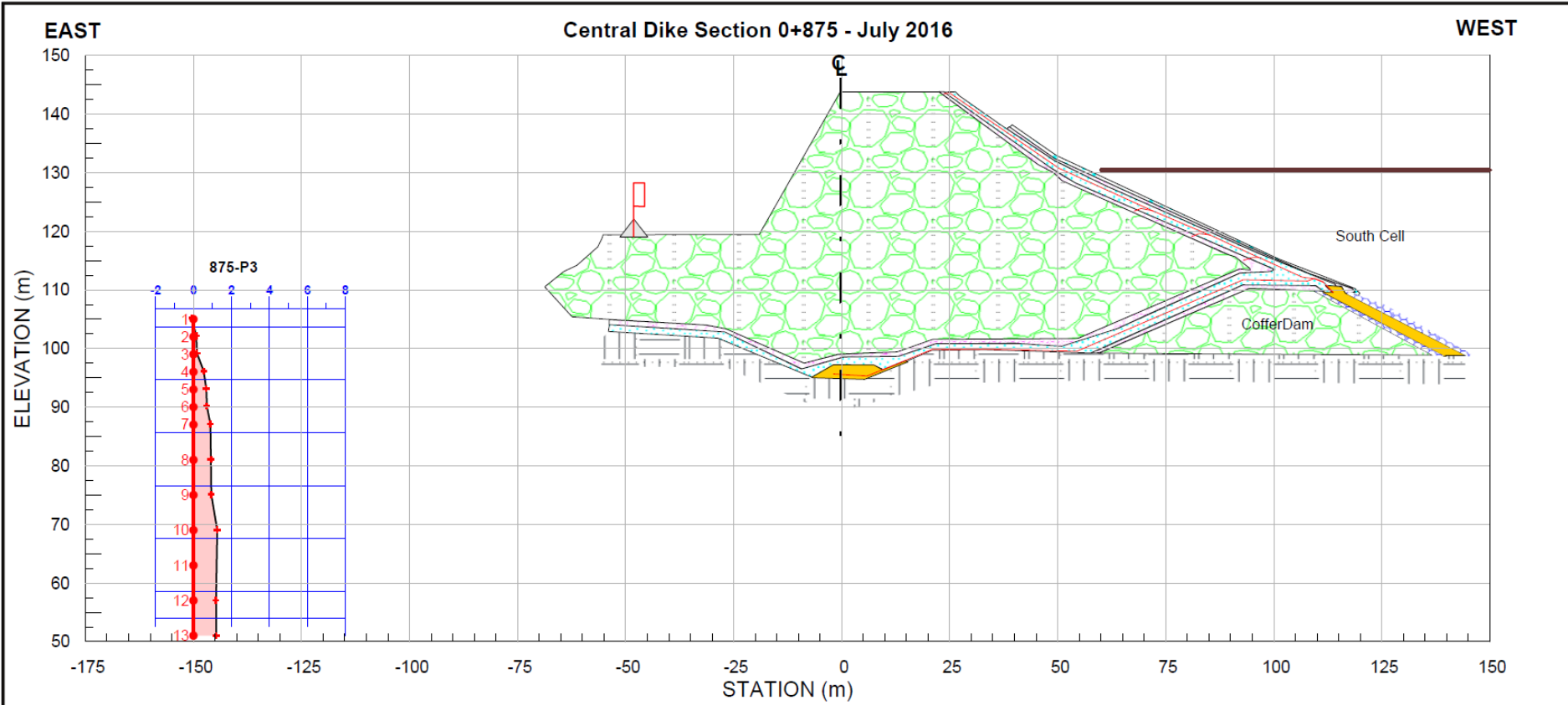
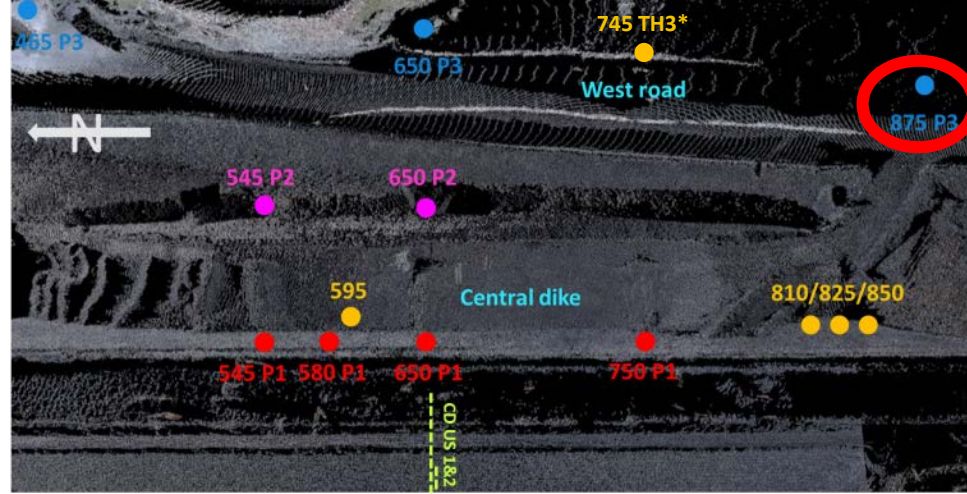

INSTRUMENTATION RESULTS

Thermistor 875 P3

AUGUST 2016

Grapher

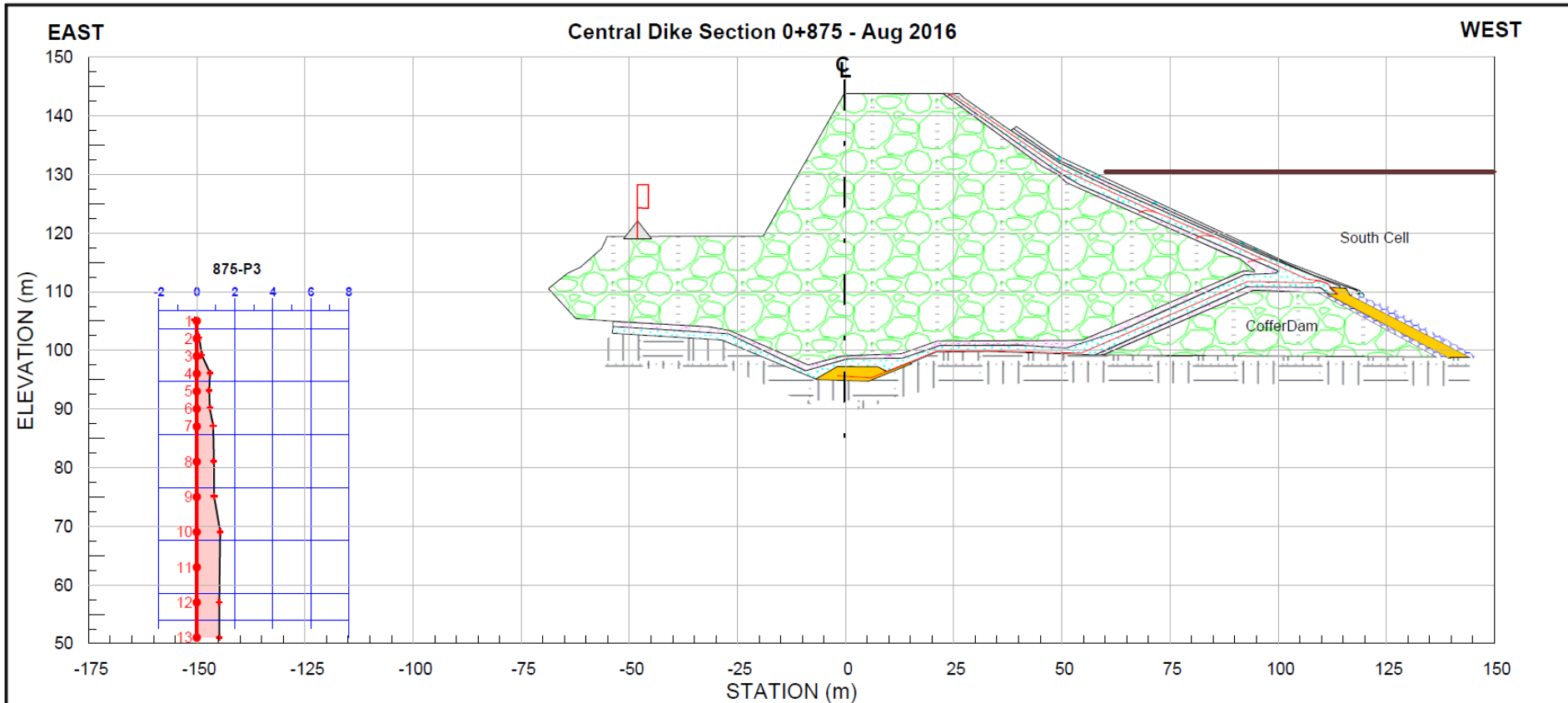
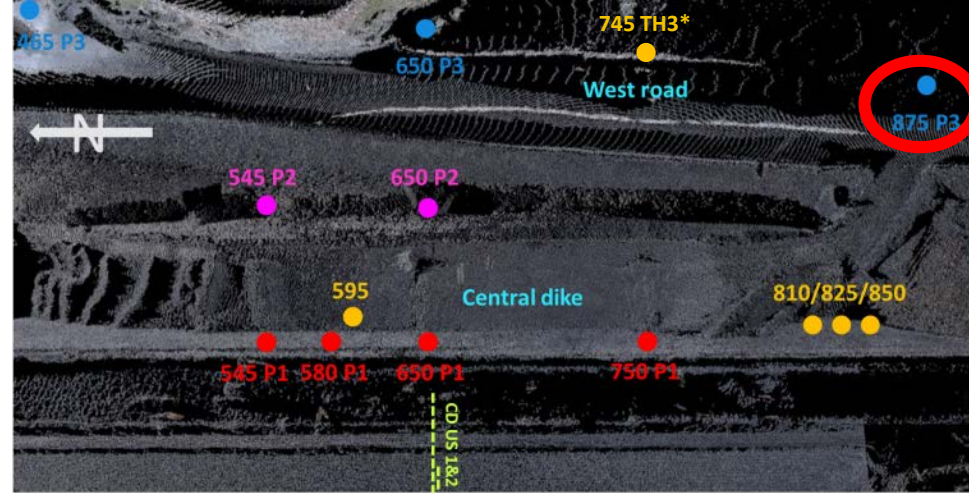

INSTRUMENTATION RESULTS

Thermistor 875 P3

FULL YEAR



AGNICO EAGLE

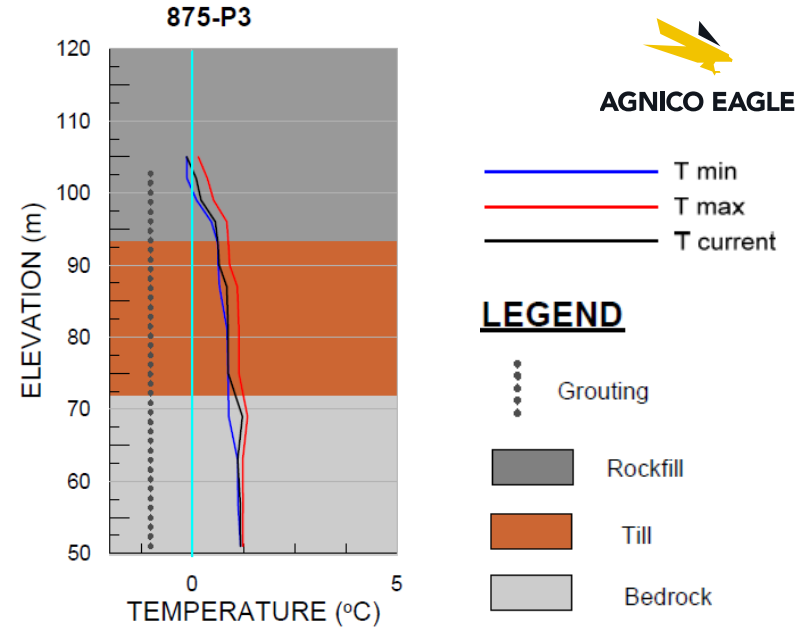

Temperature

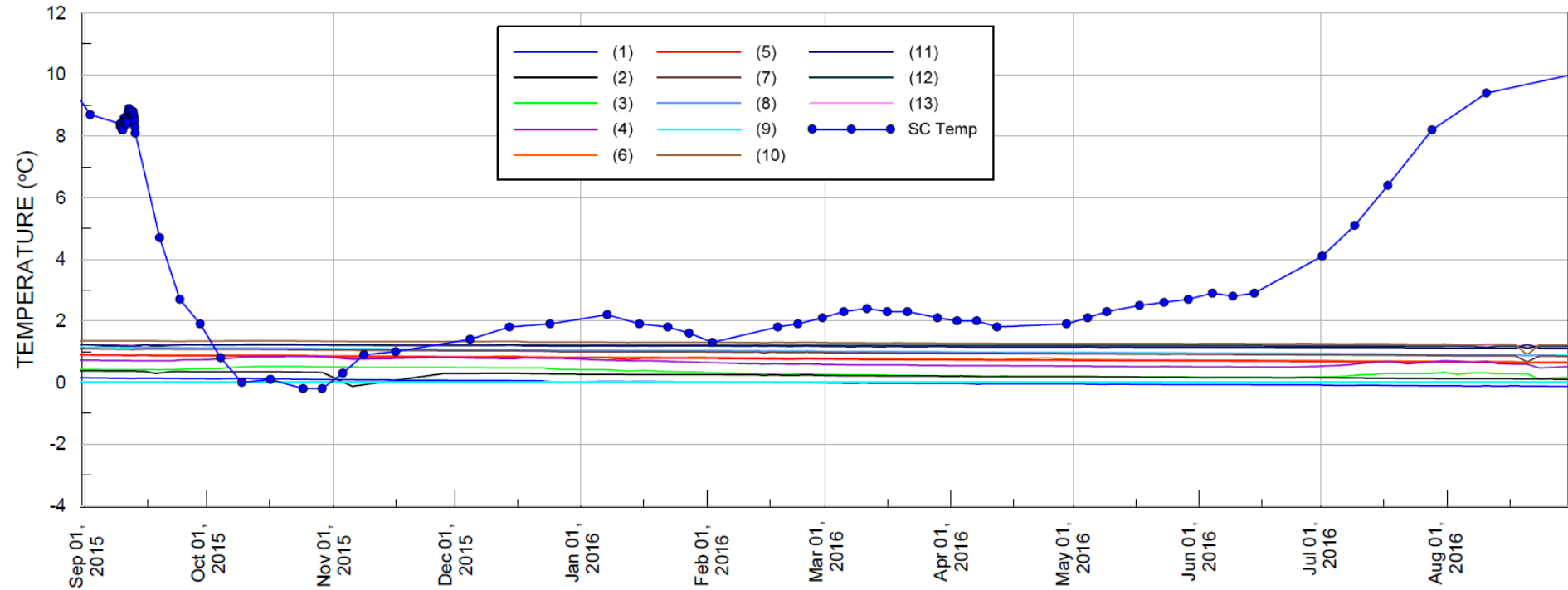



AGNICO EAGLE



THANK YOU



APPENDIX C3

TSF North Cell Instrumentation Data

STORMWATER DIKE : Summary of the movements in mm, as observed at 8 am daily.

Instruments	25-Aug	26-Aug	27-Aug	28-Aug	29-Aug	30-Aug	31-Aug	1-Sep	2-Sep	3-Sep	4-Sep	5-Sep	6-Sep	7-Sep
Extensometer (vertical movement)														
# 1	installation	7 *	11	18	24	30	35	41	46	51	54	56	58	60
# 2		installation	0	0	1	2	3	4	6	10	10	10	10	12
Cracks monitoring (horizontal movement)														
Station A	installation	2	7	8	13	14	17	17	18	19	22	/	/	/
Station B	installation	3	5	6	8	9	9	9	10	10	10	10	10	10
Station C	installation	1	4	5	6	7	9	11	12	12	12	12	13	13
Station D	installation	0	0	0	0	0	0	1	2	2	2	2	2	2
Prisms (3D movement)														
# A	installation	0	0	0	16.1		25	34	37	41	43	49	52	56
# B	installation	0	0	0	23		33	43	45	51	55	59	62	66
# C	installation	0	0	0	19.6		31	39	40	44	47	51	53	58

* very windy on the crest

Instruments	8-Sep	9-Sep	10-Sep	11-Sep	12-Sep	13-Sep	14-Sep	15-Sep	16-Sep	17-Sep	18-Sep	19-Sep	20-Sep	21-Sep
Extensometer (vertical movement)														
# 1	63	66	68	70	71.5	74	76	78	79	80	81.5	82.5	83	84
# 2	12	14	14	15.4	16	17	18	20	21	21	21	19.5	19	20
Cracks monitoring (horizontal movement)														
Station A	/	/	/	/	/	/	/	/	/	/	/	/	/	/
Station B	10	10	10	10	9	9	8	8	8	8	9	9	8	9
Station C	13	13	13	13	13	13	12	13	13	13	13	13	12	12
Station D	2	2	2	2	2	2	1	1	1	2	2	1	0	1
Prisms (3D movement)														
# A	59	No readings	63	67	72	76	77	81	83	No readings	89	90	94	99
# B	69	due to heavy	75	80	83	85	88	91	93	due to heavy	100	100	103	108
# C	61	fog all day	62	71	72	74	75	76	79	fog all day	83	82	85	90

Instruments	22-Sep	23-Sep	24-Sep	25-Sep	26-Sep	27-Sep	28-Sep	29-Sep	30-Sep	3-Oct
Extensometer (vertical movement)										
# 1	85	84	84	85	87	89	90	90	90	90
# 2	20	19	19	20	20	20	20	20	20	20
Cracks monitoring (horizontal movement)										
Station A	/	/								
Station B	9	9	9	8	7	8	8	8	8	8
Station C	13	13	13	12	11	12	12	12	12	12
Station D	1	0	0	1	1	1	1	1	1	1
Prisms (3D movement)										
# A	101	102	102	no reading			No readings	108	102	103
# B	108	110	110	118			due to heavy	117	116	117
# C	90	90	90	90			fog this morning	92	90	86



AGNICO EAGLE



MDRB #19 TAILINGS STORAGE FACILITIES INSTRUMENTATION REVIEW

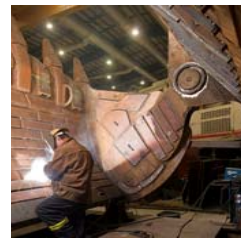

TSF- OPERATIONAL STRUCTURES



NORTH CELL

Rockfill Road 1 and 2

Thermistor – 3 Total
T121-1, T122-1 and T73-6

Saddle Dam 1

Thermistor – 4 Total
T1, T2, T3 and T4



Saddle Dam 2

Thermistor – 4 Total
T1, T2, T3 and T4

Stormwater Dike

Piezometer – 1 Total VWP 13265
Thermistor – 1 Total T147-1

SADDLE DAM 1 - REVIEW OF INSTRUMENTATION



THERMISTORS EMPLACEMENT - T1, T2, T3 AND T4

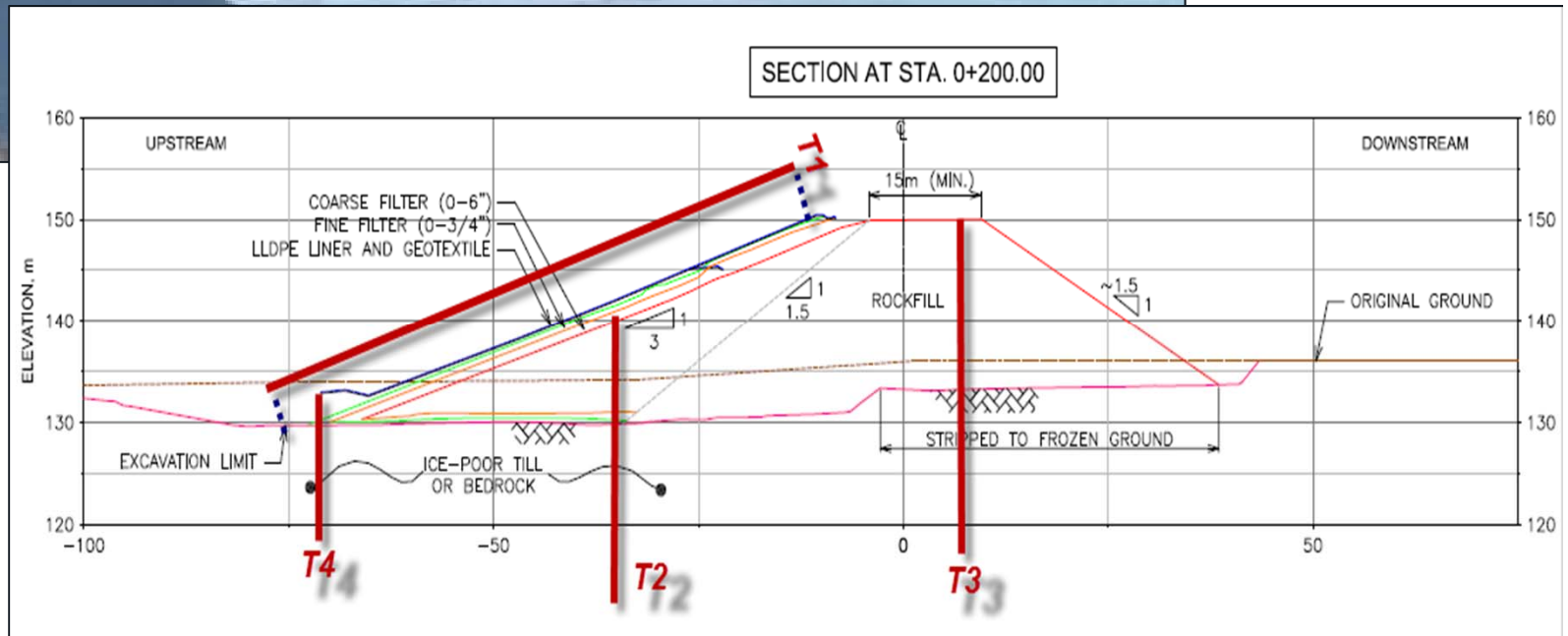

SADDLE DAM 1 - T1

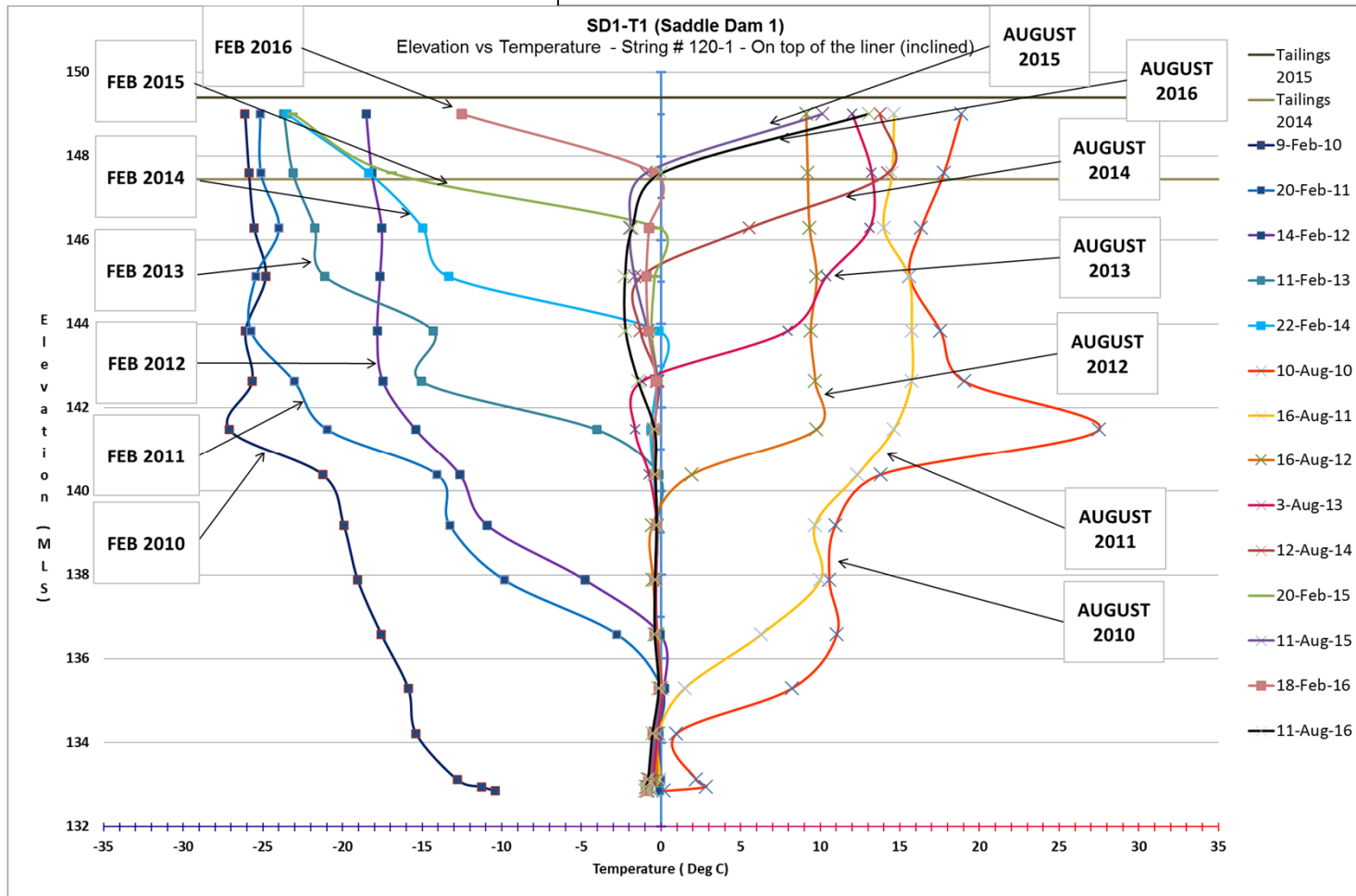
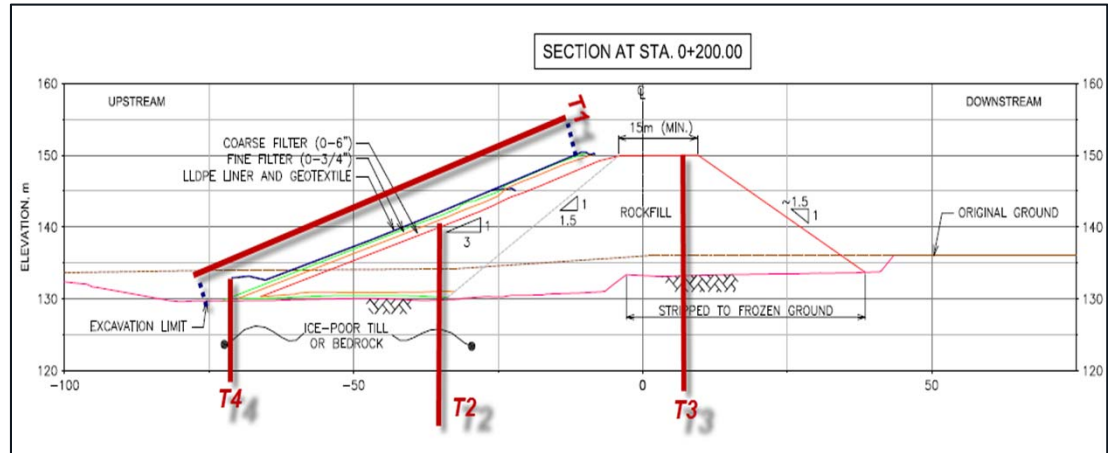

SADDLE DAM 1 - T1

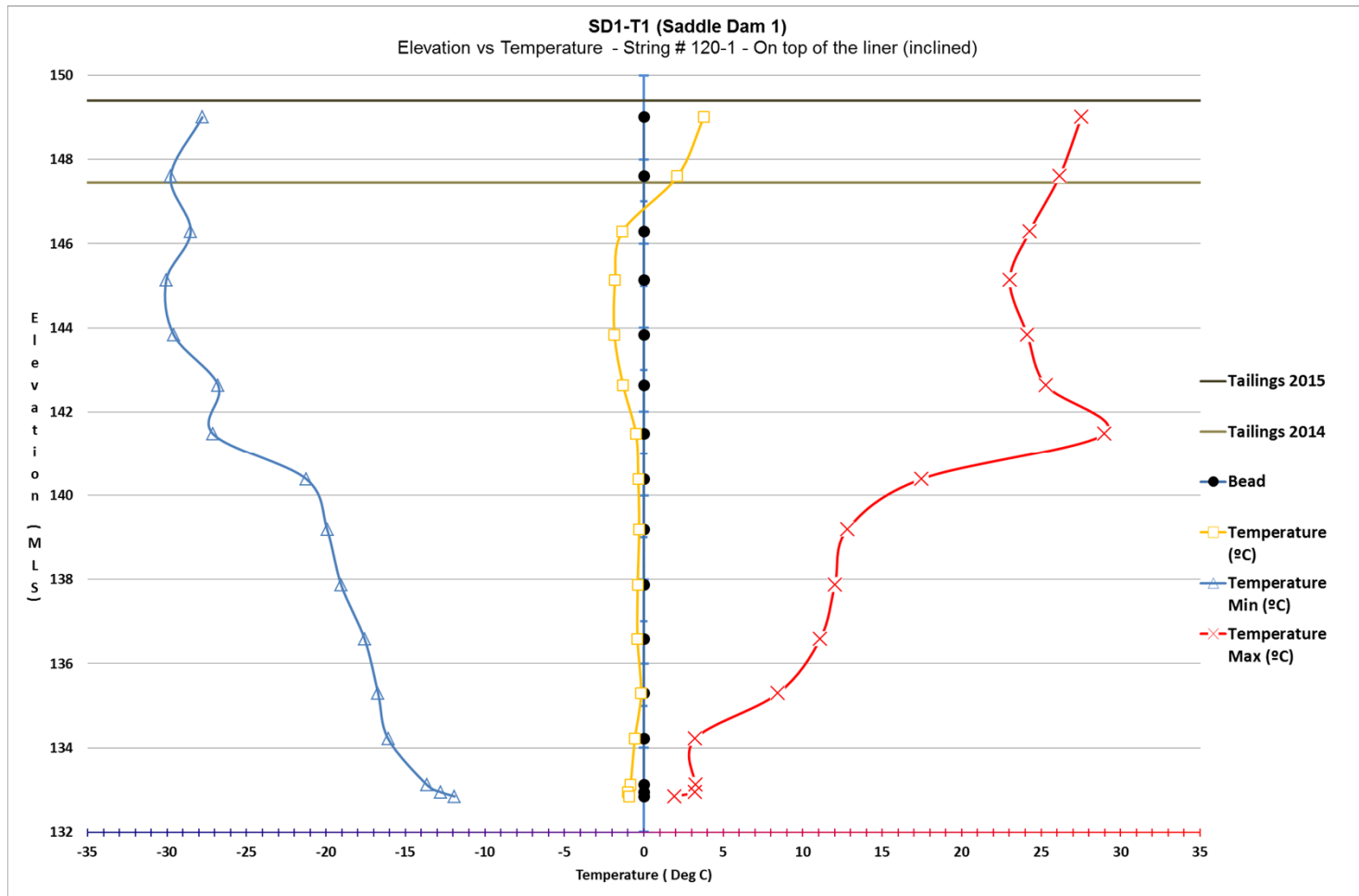
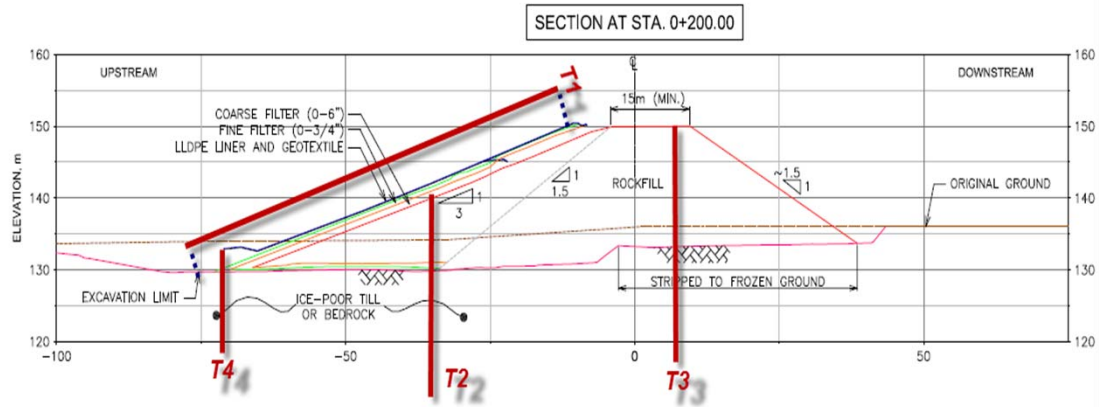

SADDLE DAM 1 - T2

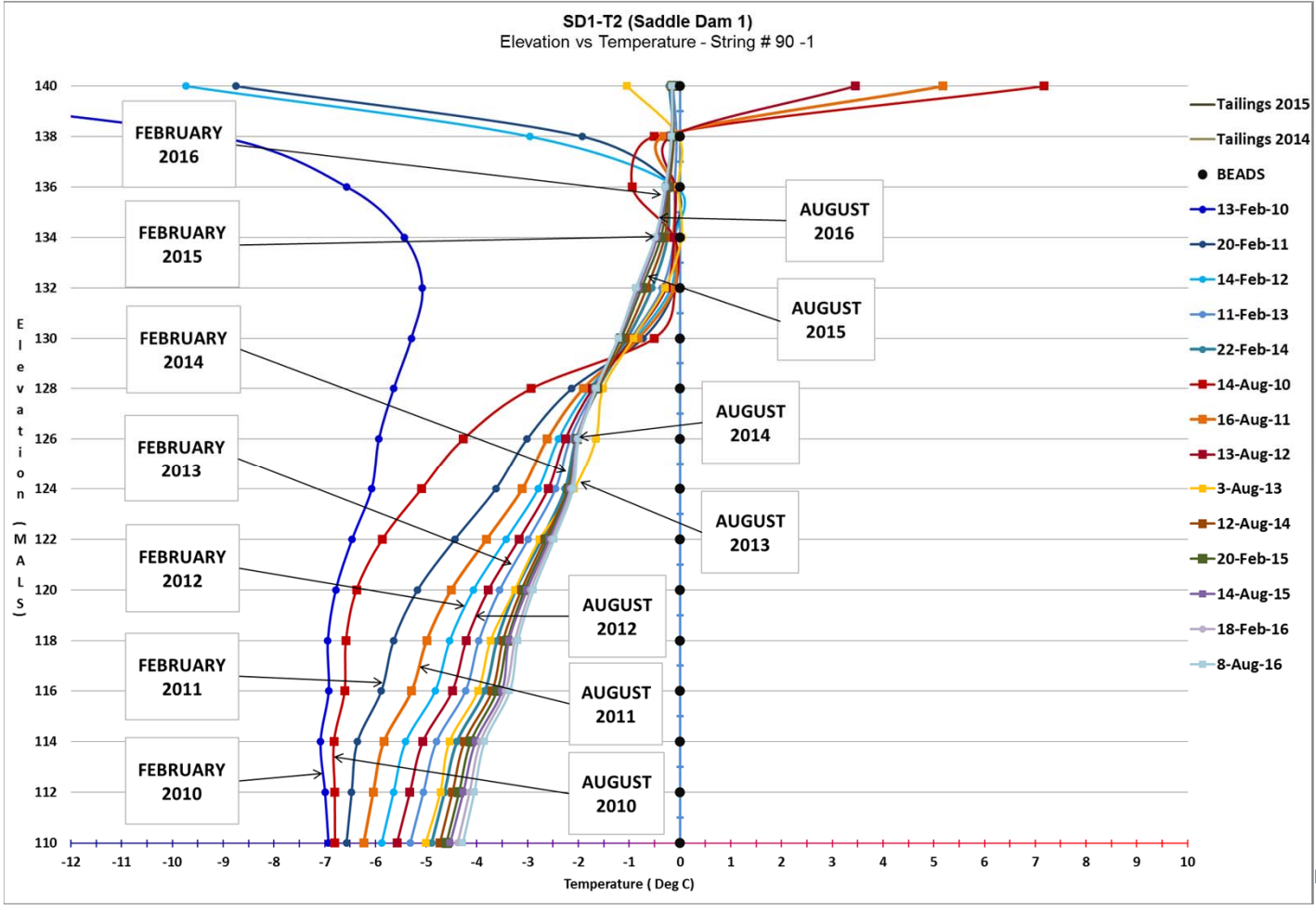
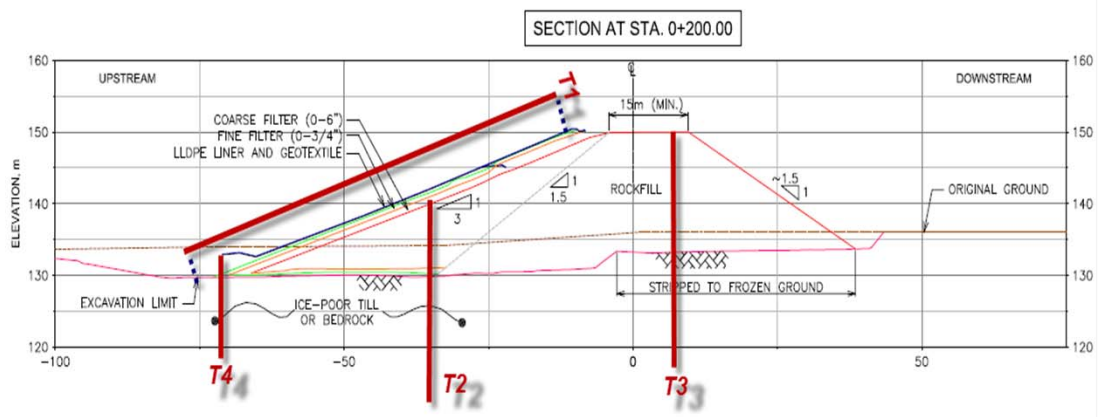

SADDLE DAM 1 - T2

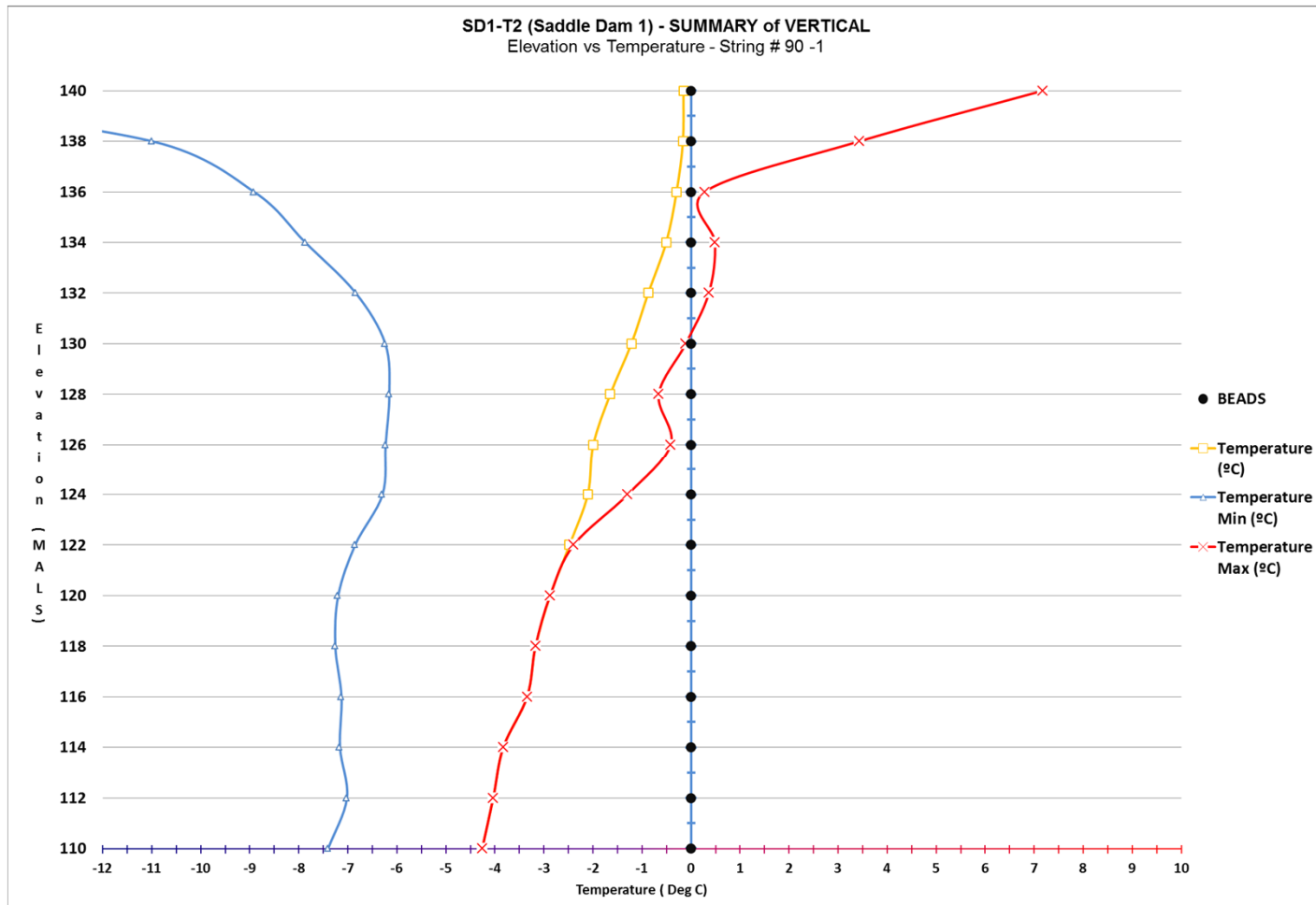
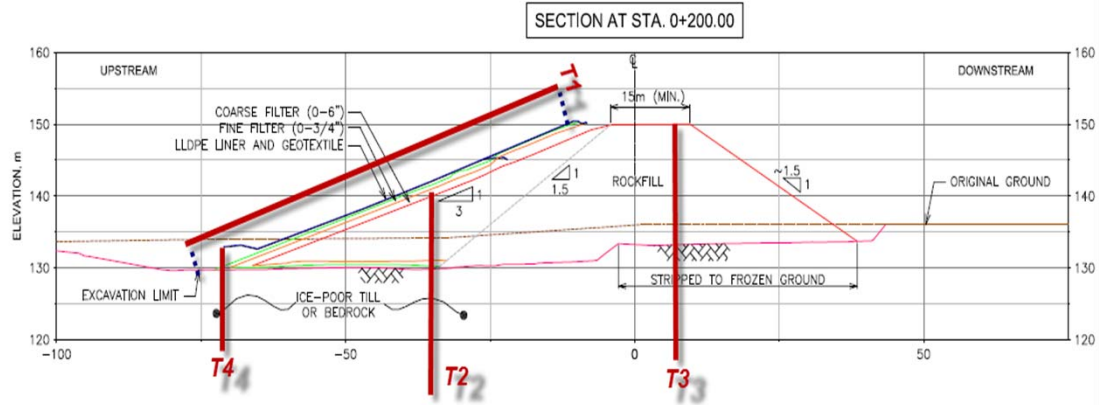

SADDLE DAM 1 - T3

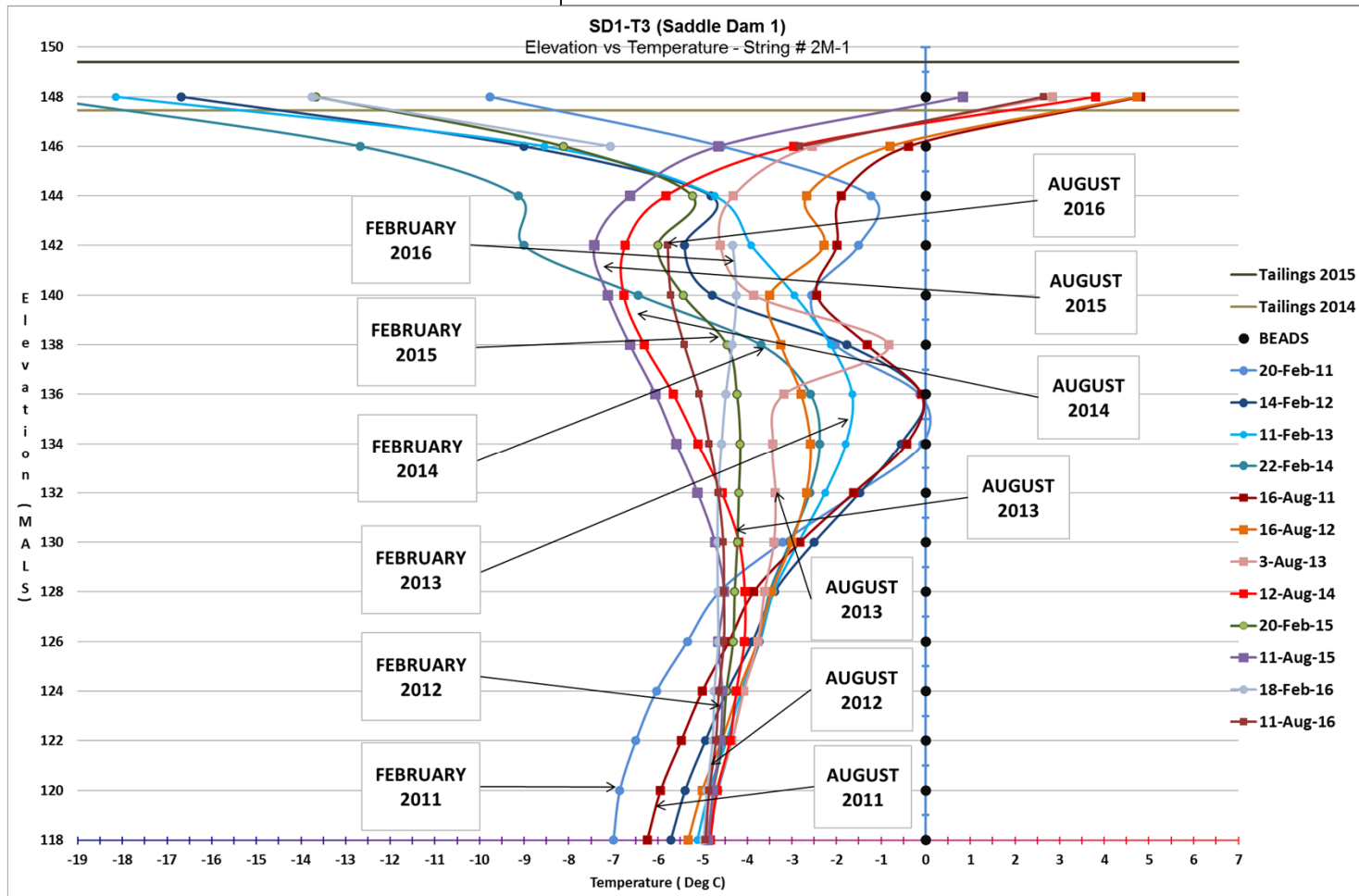
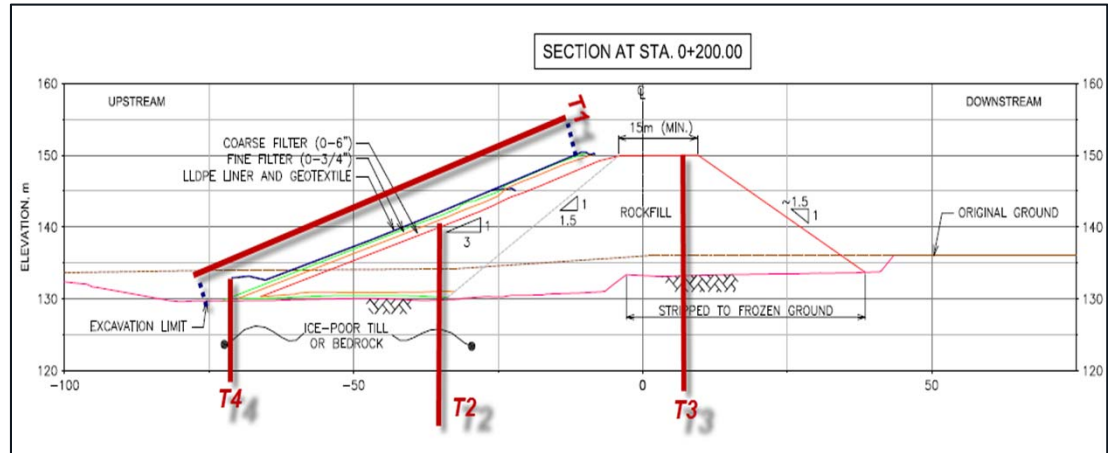

SADDLE DAM 1 - T3

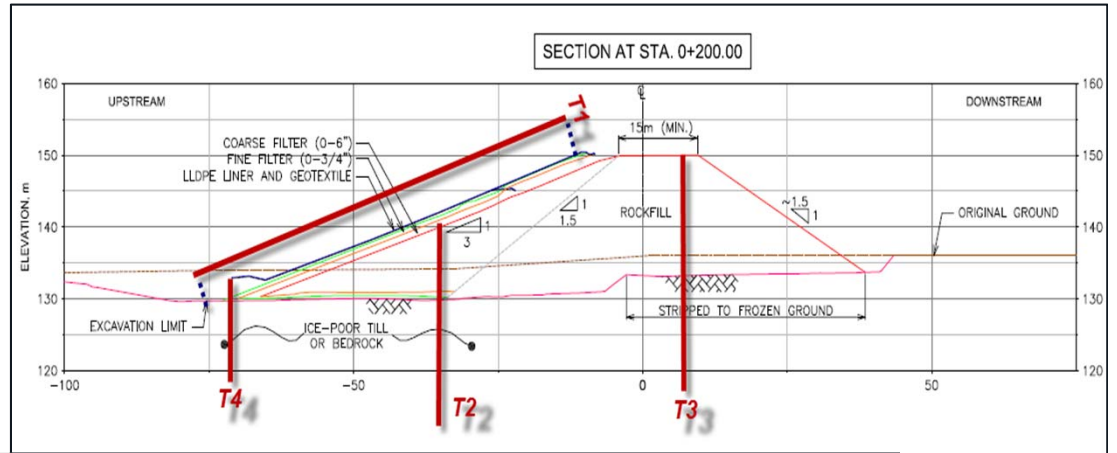

SD1-T3 (Saddle Dam 1) - SUMMARY OF VERTICAL Elevation vs Temperature - String # 2M-1

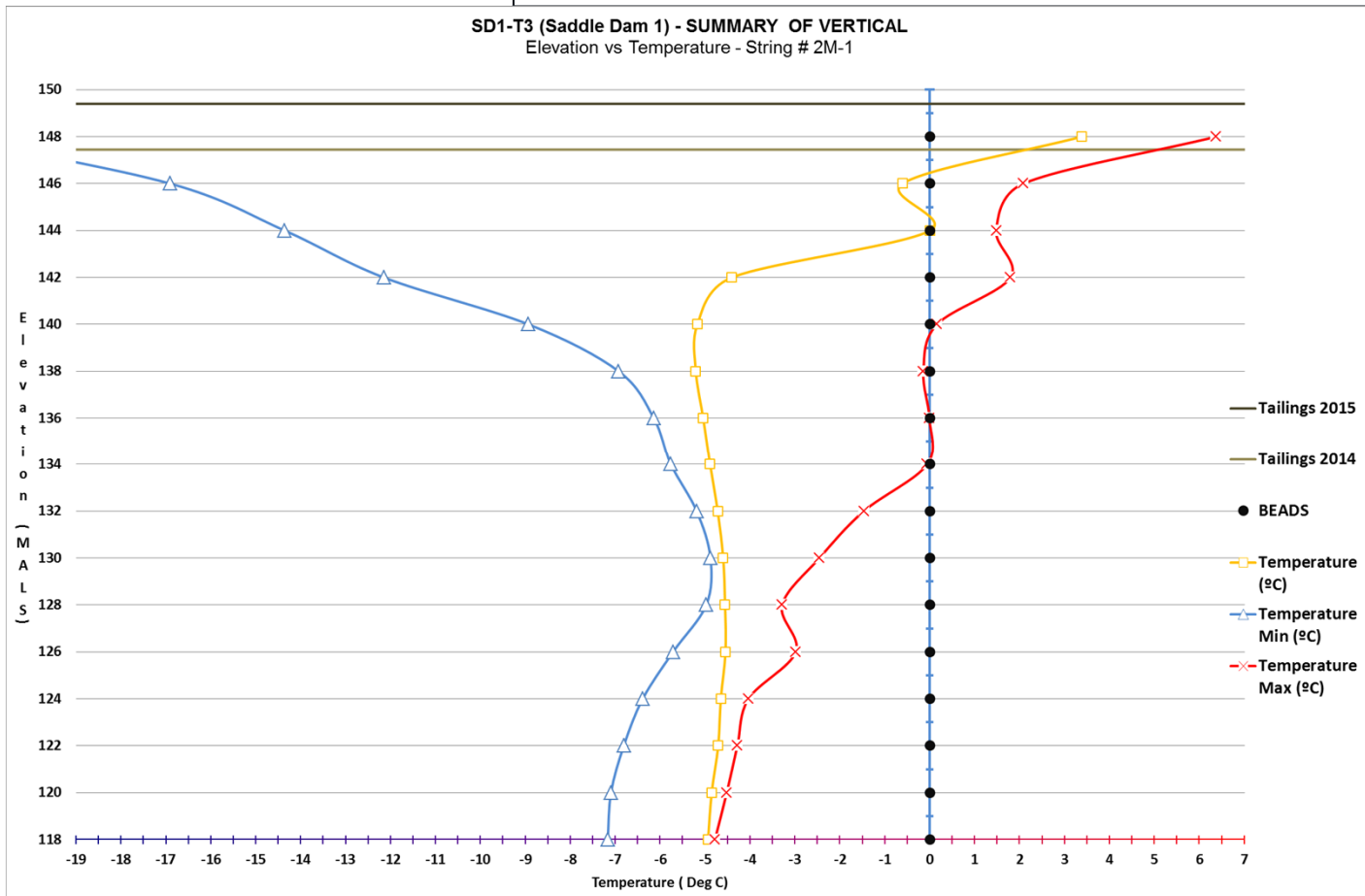

SADDLE DAM 1 - T4

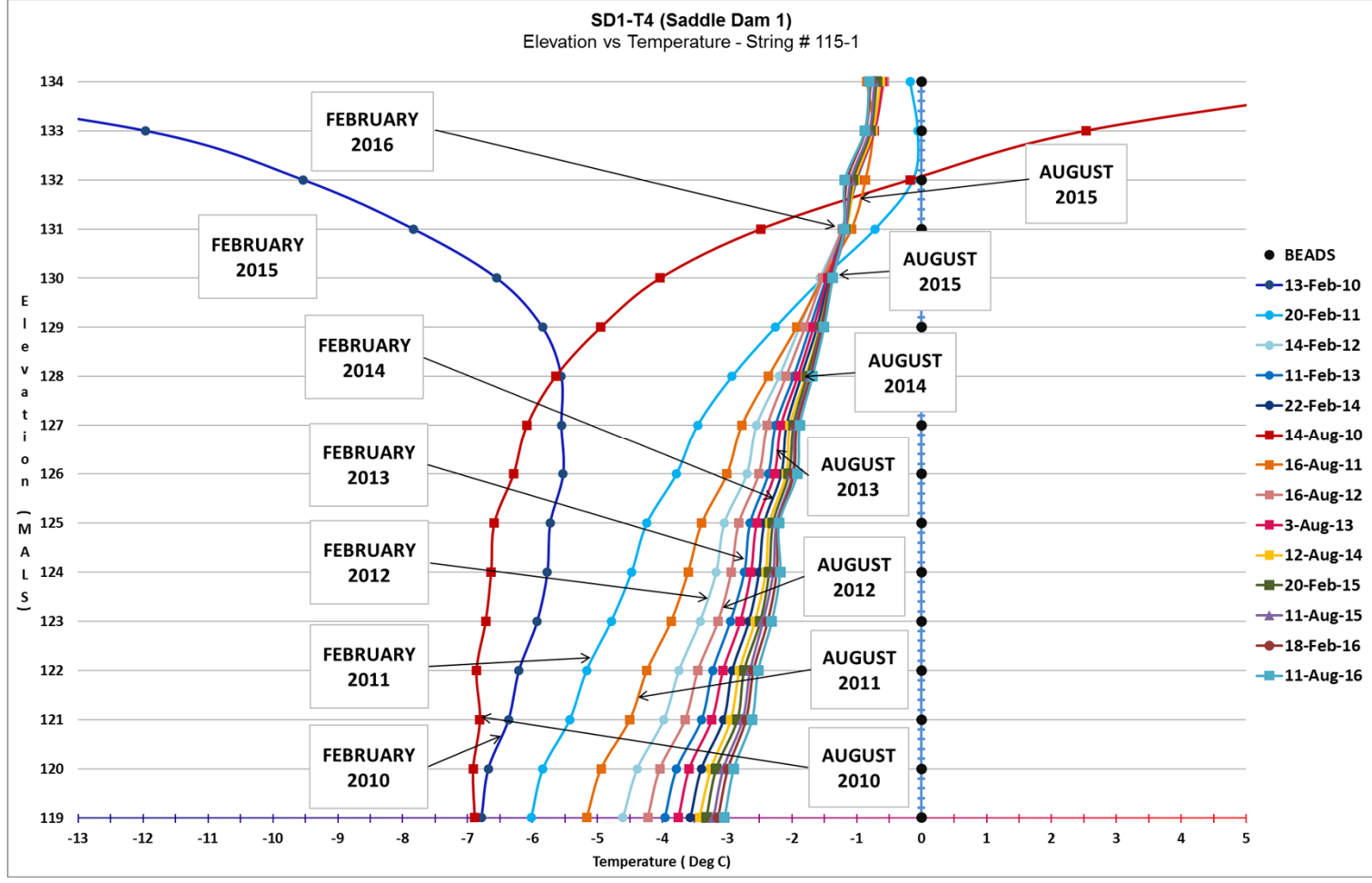
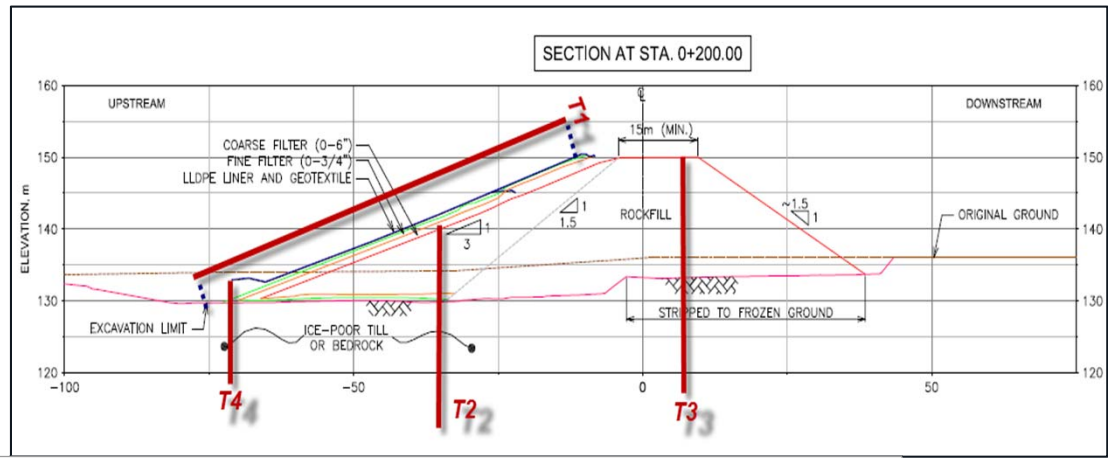

SADDLE DAM 1 - T4

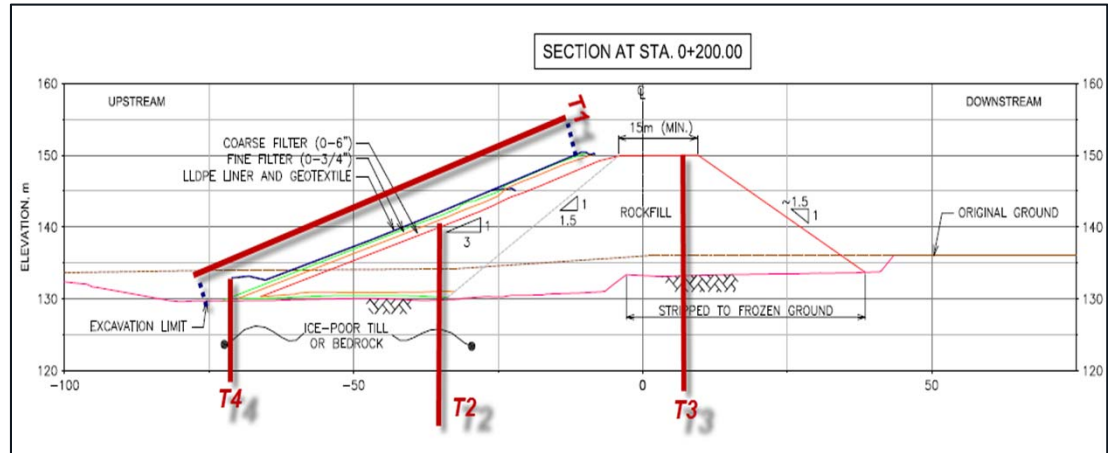

SD1-T4 (Saddle Dam 1) - SUMMARY OF VERTICAL
Summary of Vertical- String # 115-1

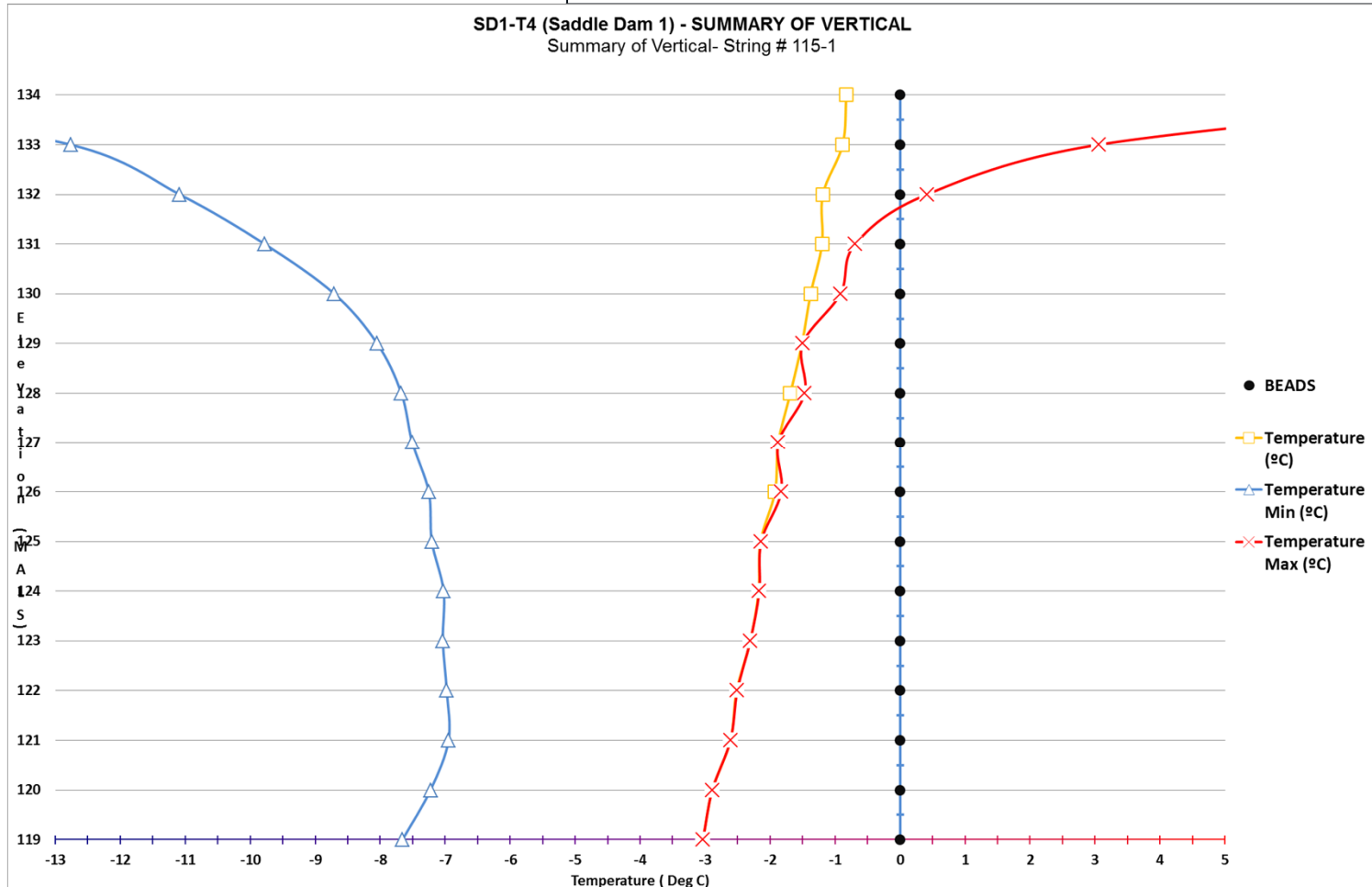

SADDLE DAM 2 - REVIEW OF INSTRUMENTATION

THERMISTORS EMPLACEMENT - T1, T2, T3 AND T4

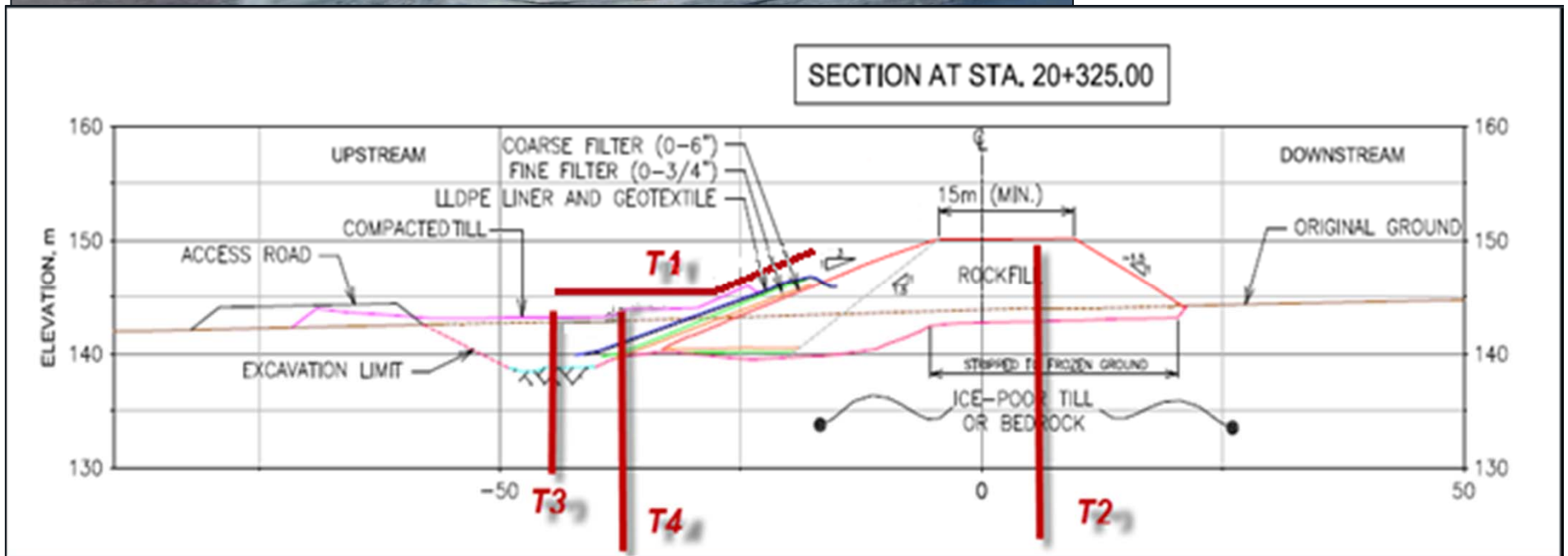

SADDLE DAM 2

- T1

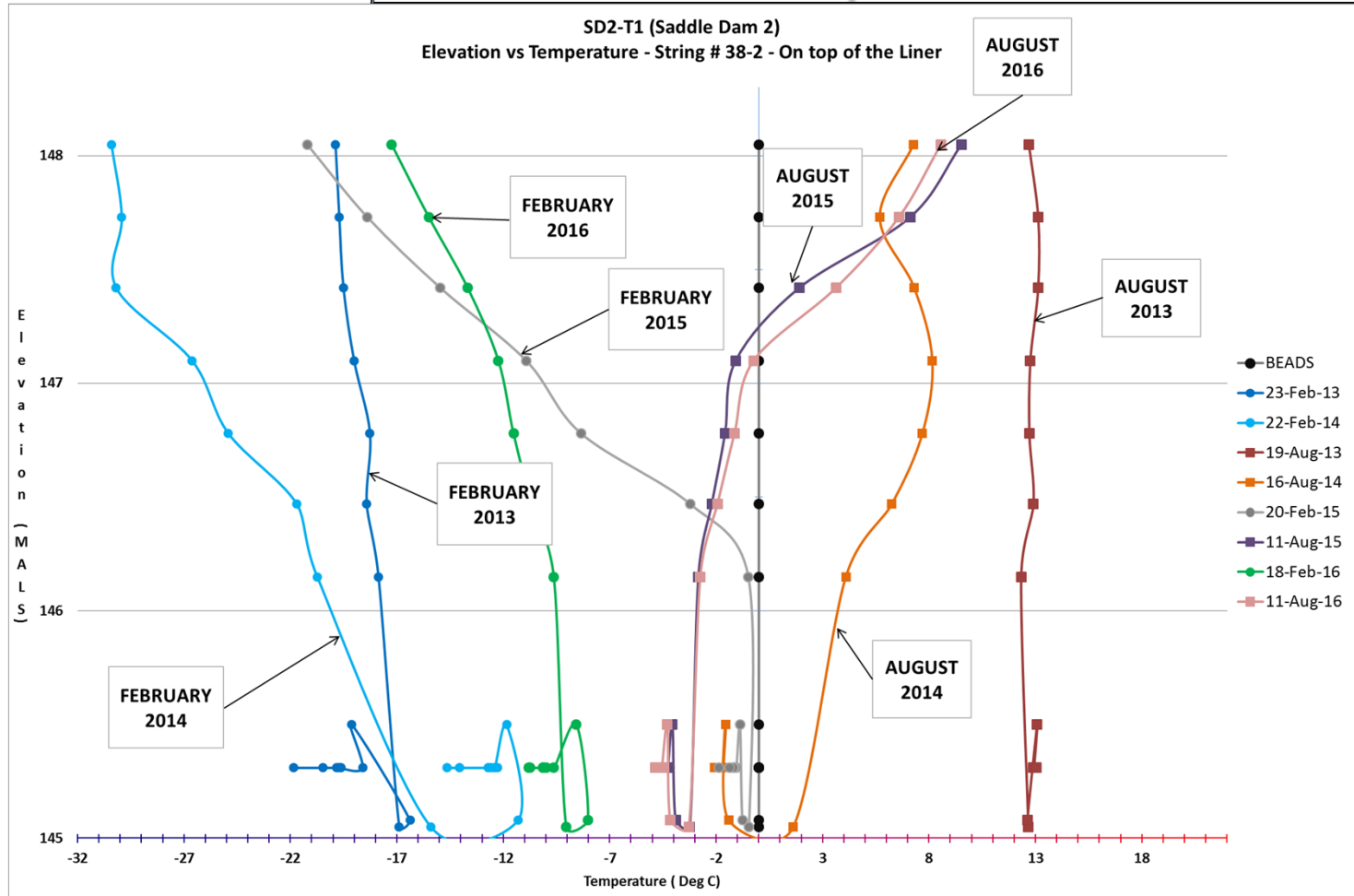
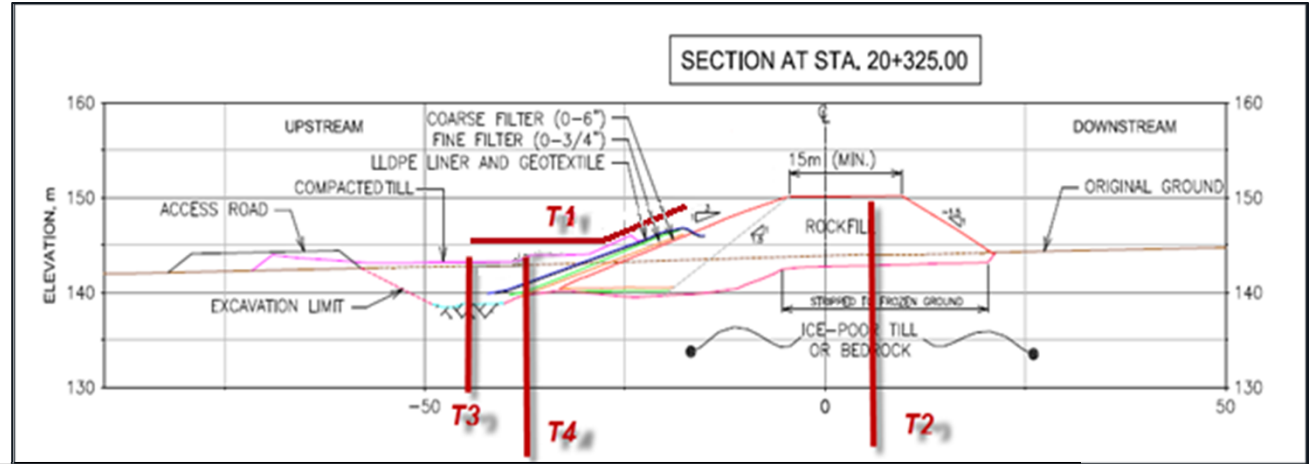

SADDLE DAM 2

- T1

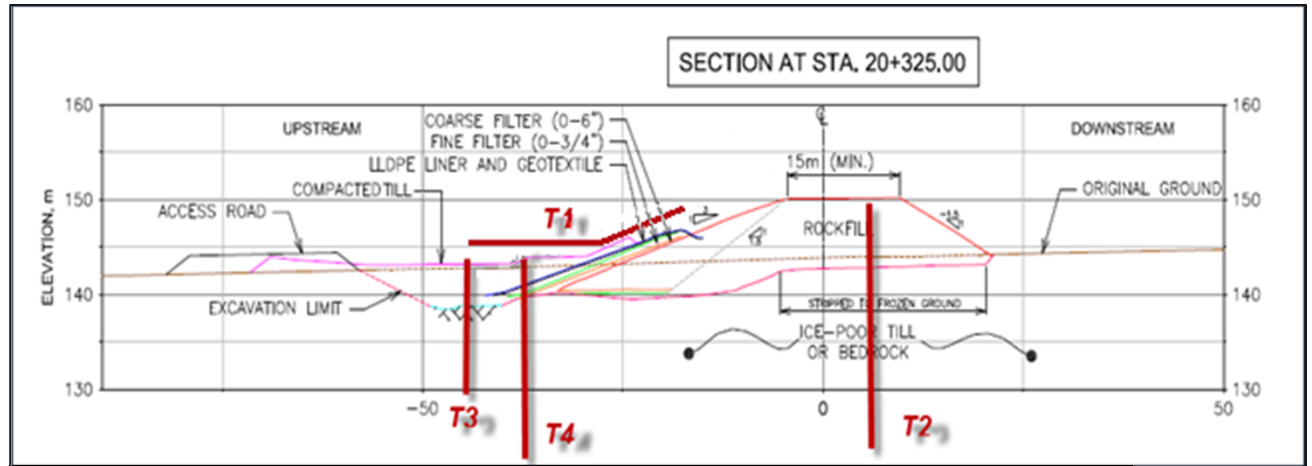

SD2-T1 (Saddle Dam 1) SUMMARY OF VERTICAL
Elevation vs Temperature - String # 38-2 - On top of Liner

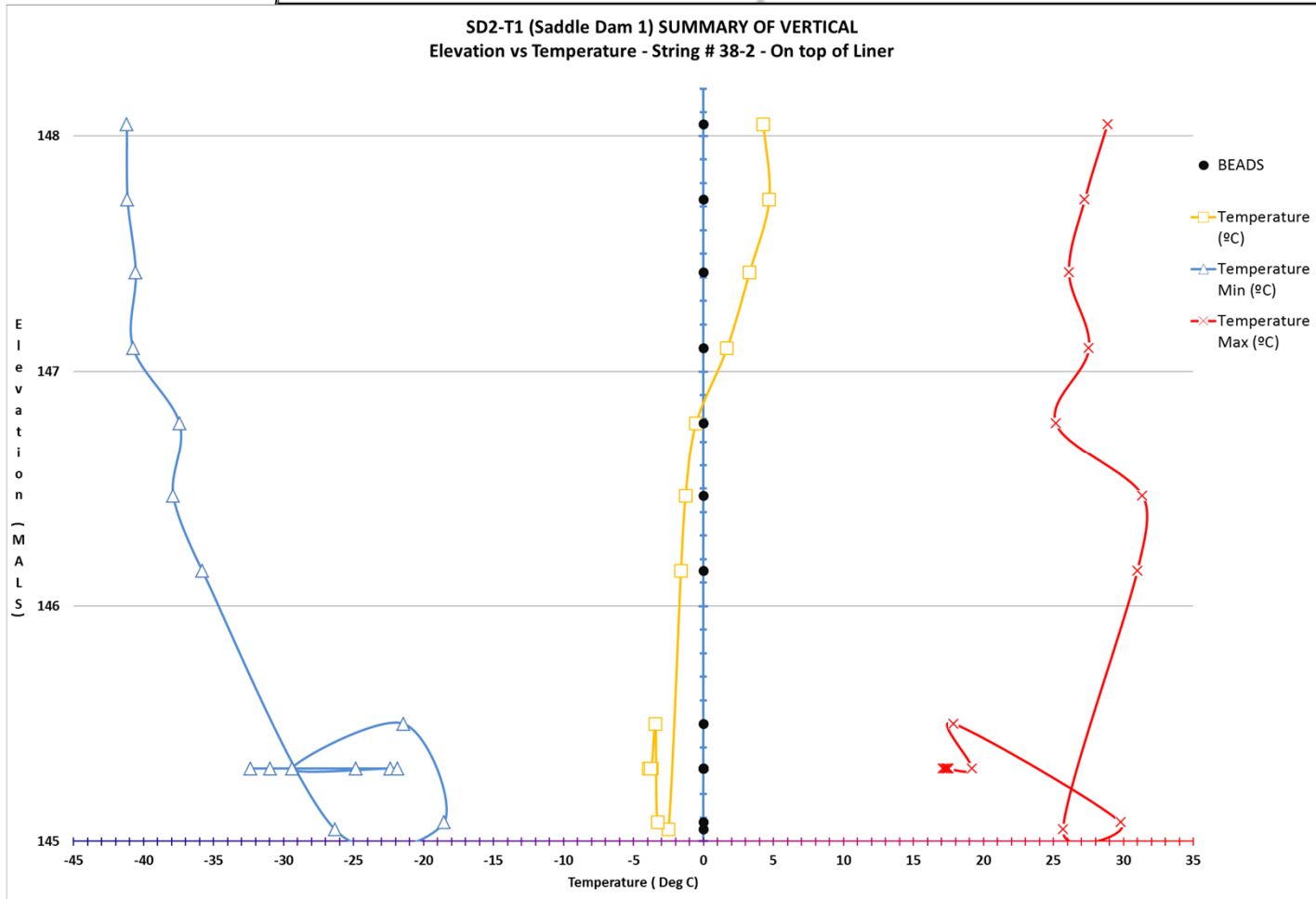

SADDLE DAM 2

- T2

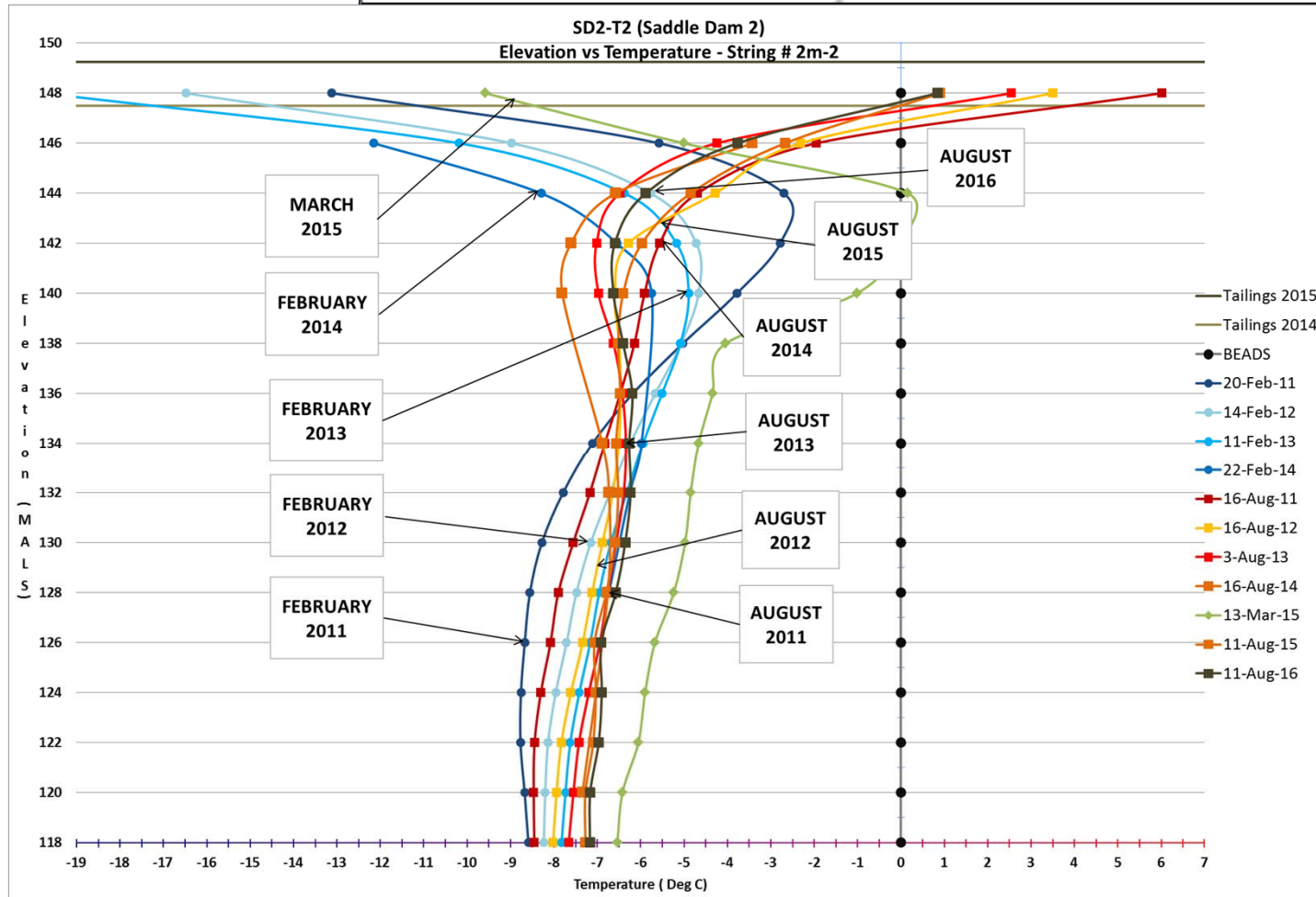
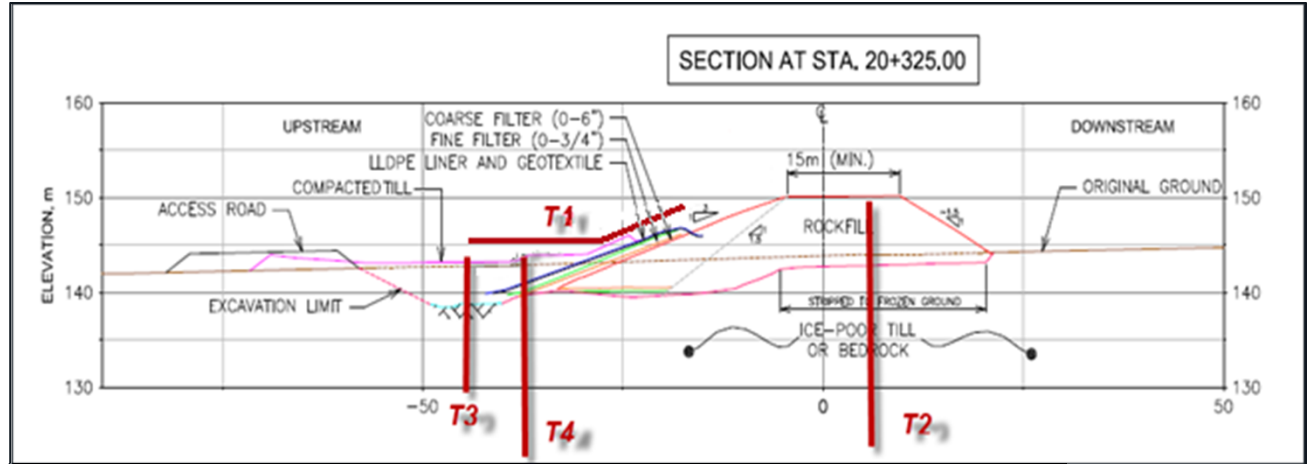

SADDLE DAM 2

- T2

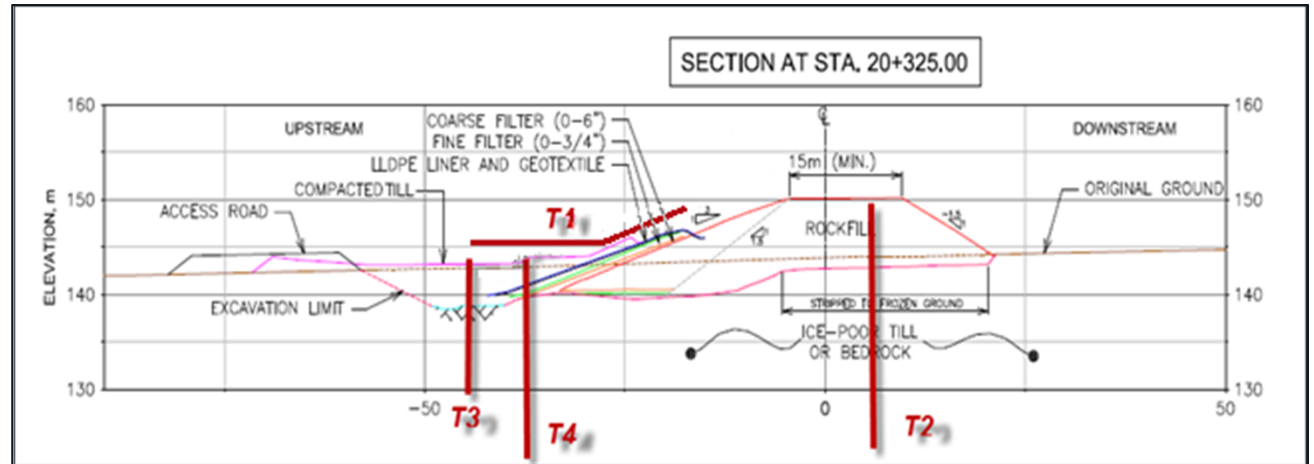

SD2-T2 (Saddle Dam 2) SUMMARY OF VERTICAL Elevation vs Temperature - String # 2M-2

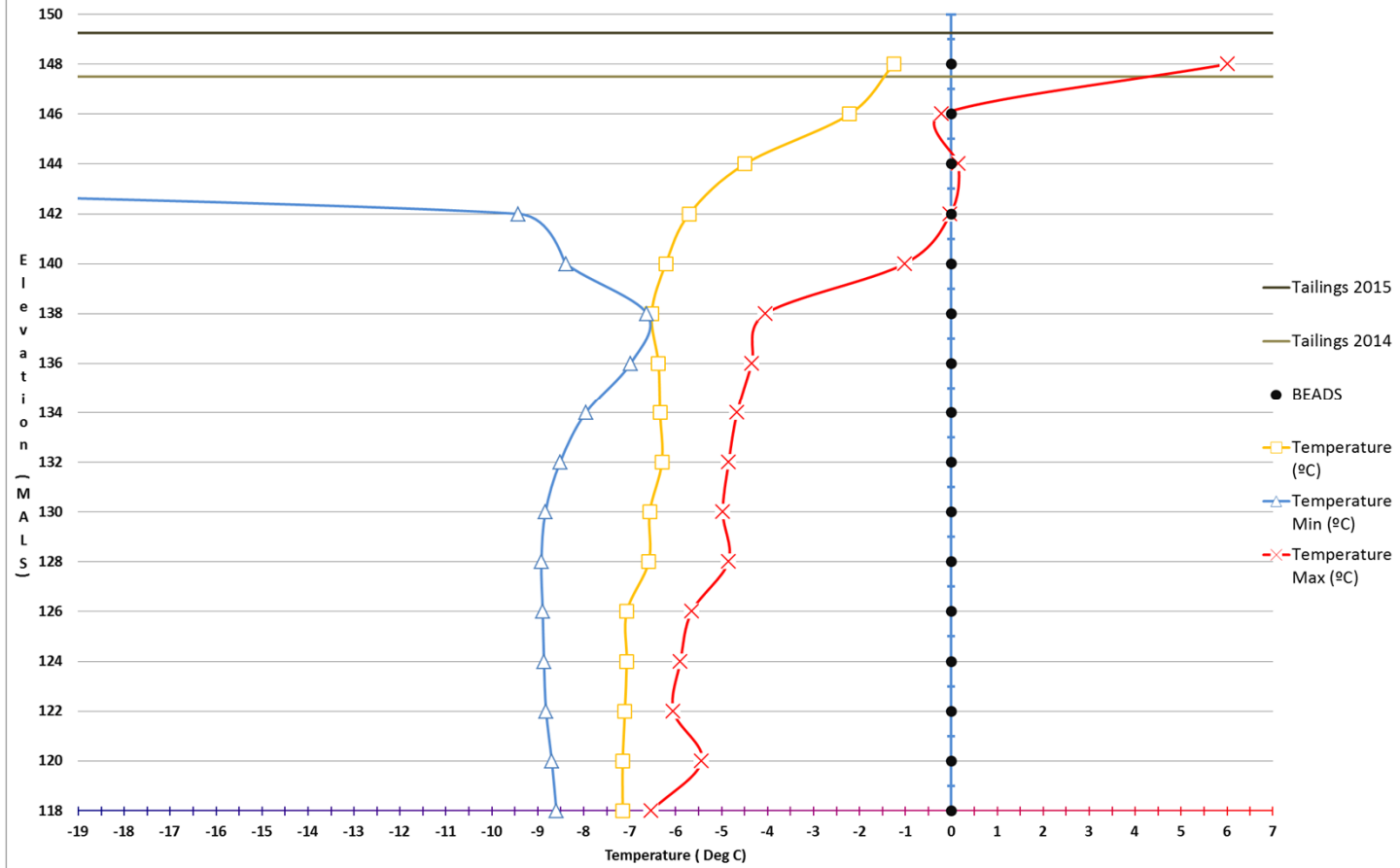

SADDLE DAM 2

- T3

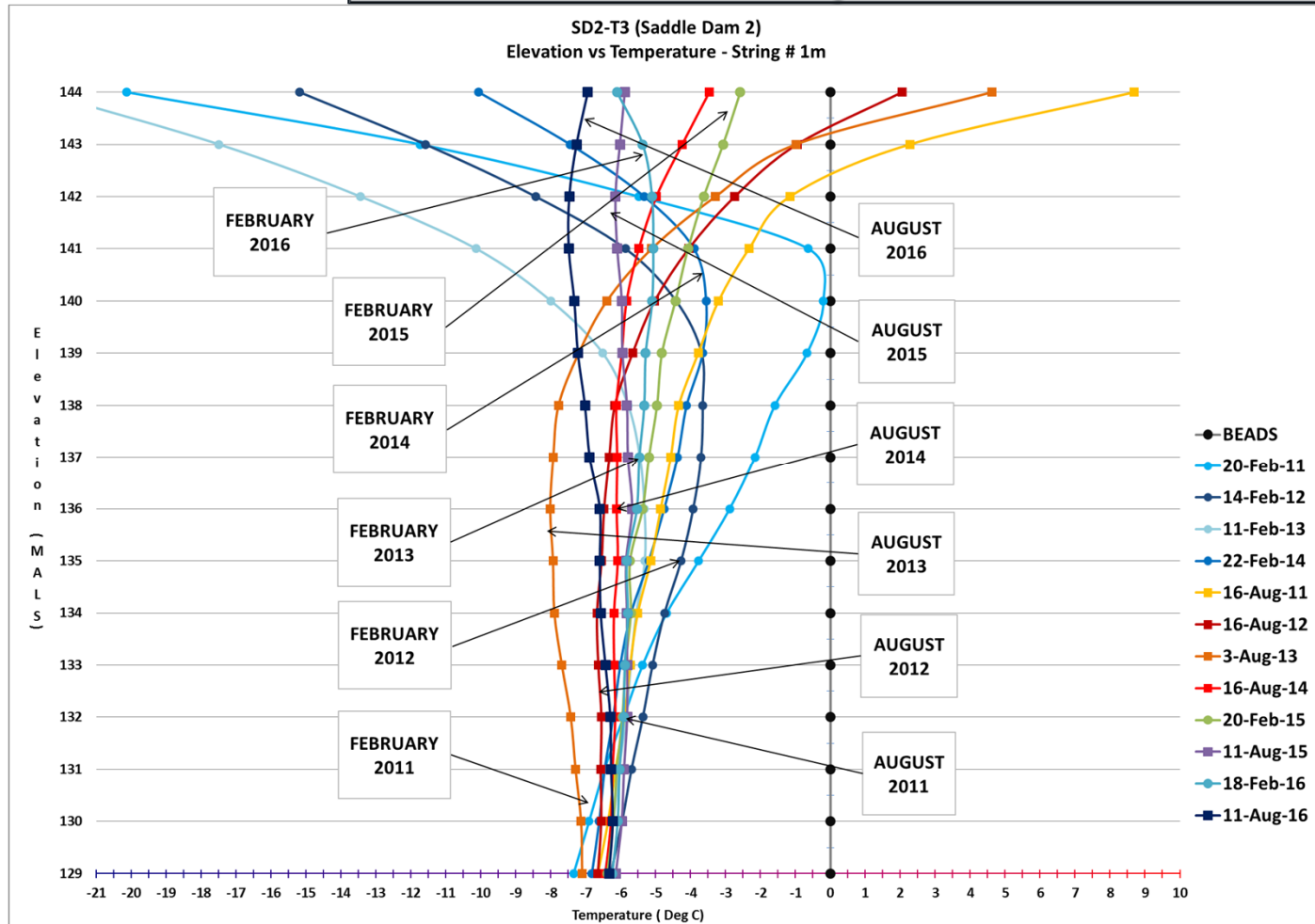
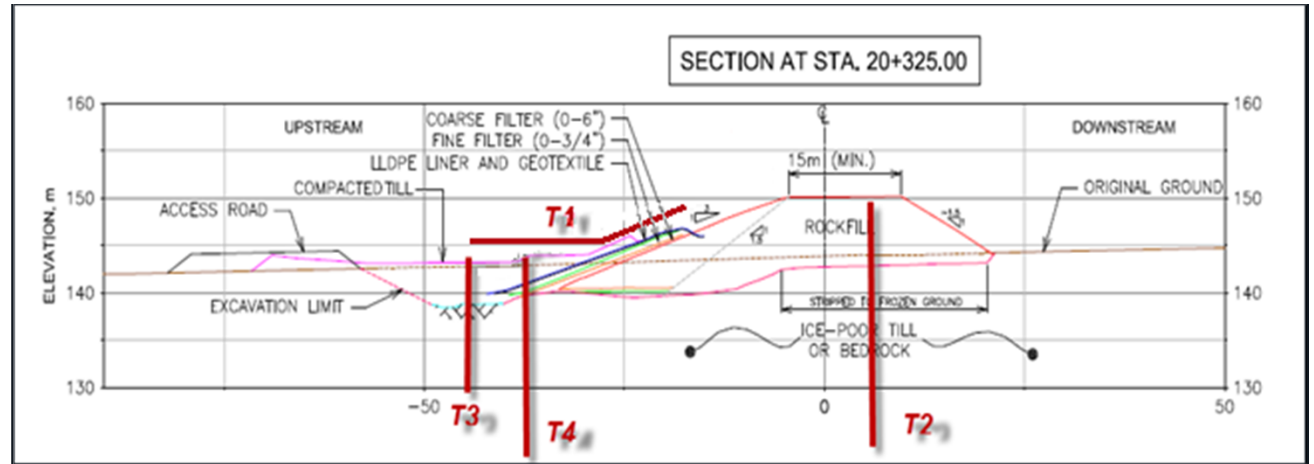

SADDLE DAM 2

- T3

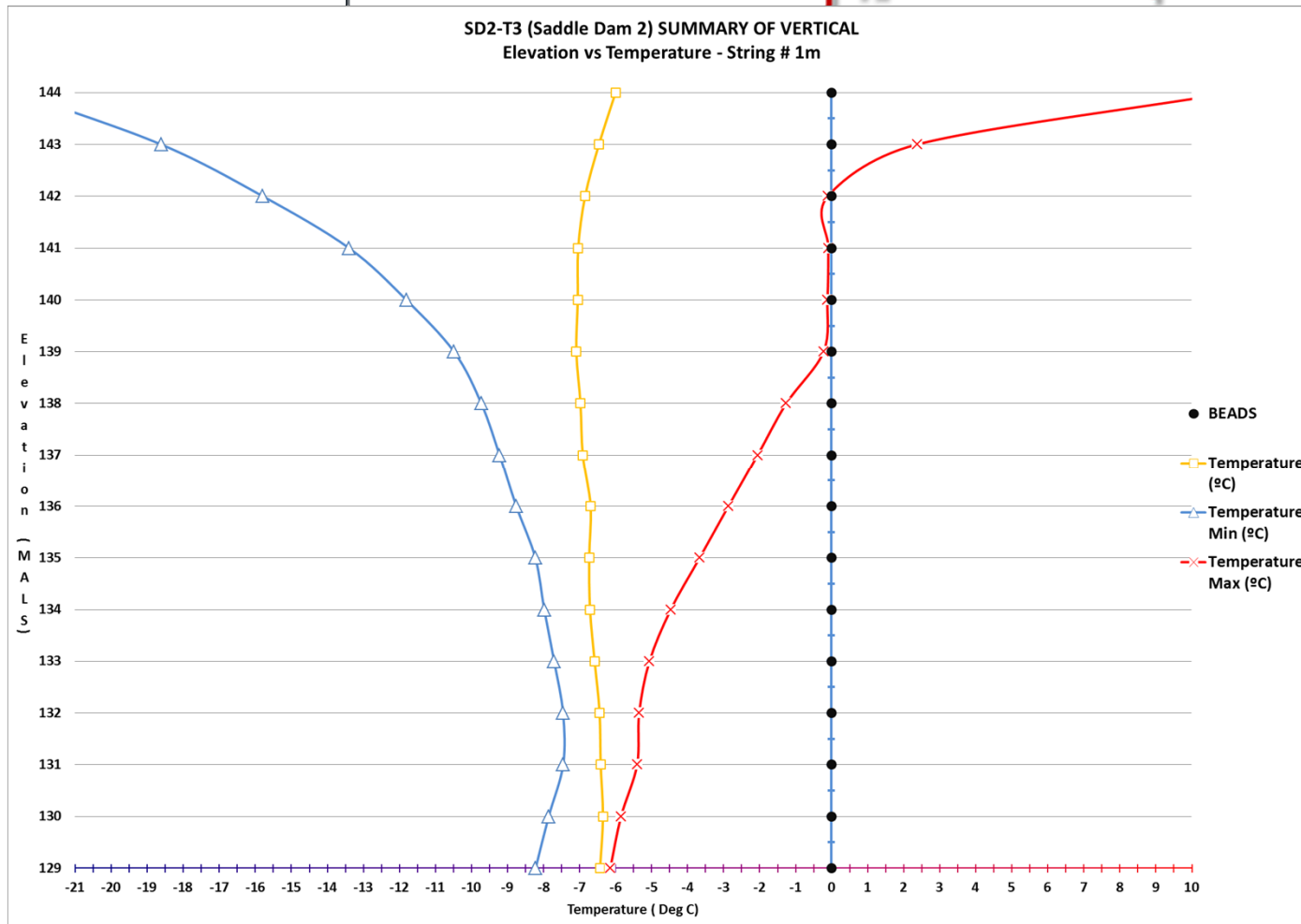
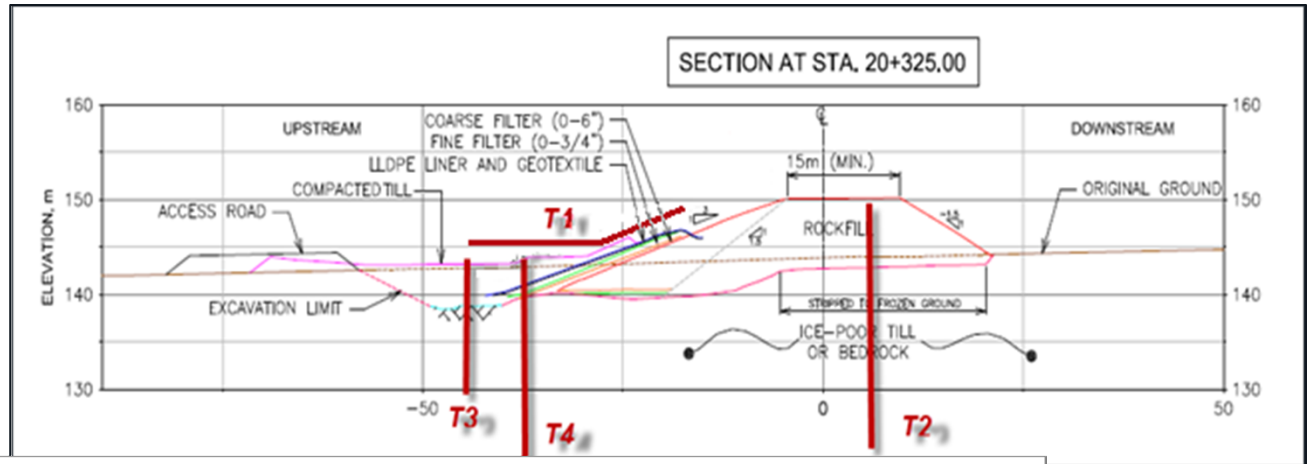

SADDLE DAM 2

- T4

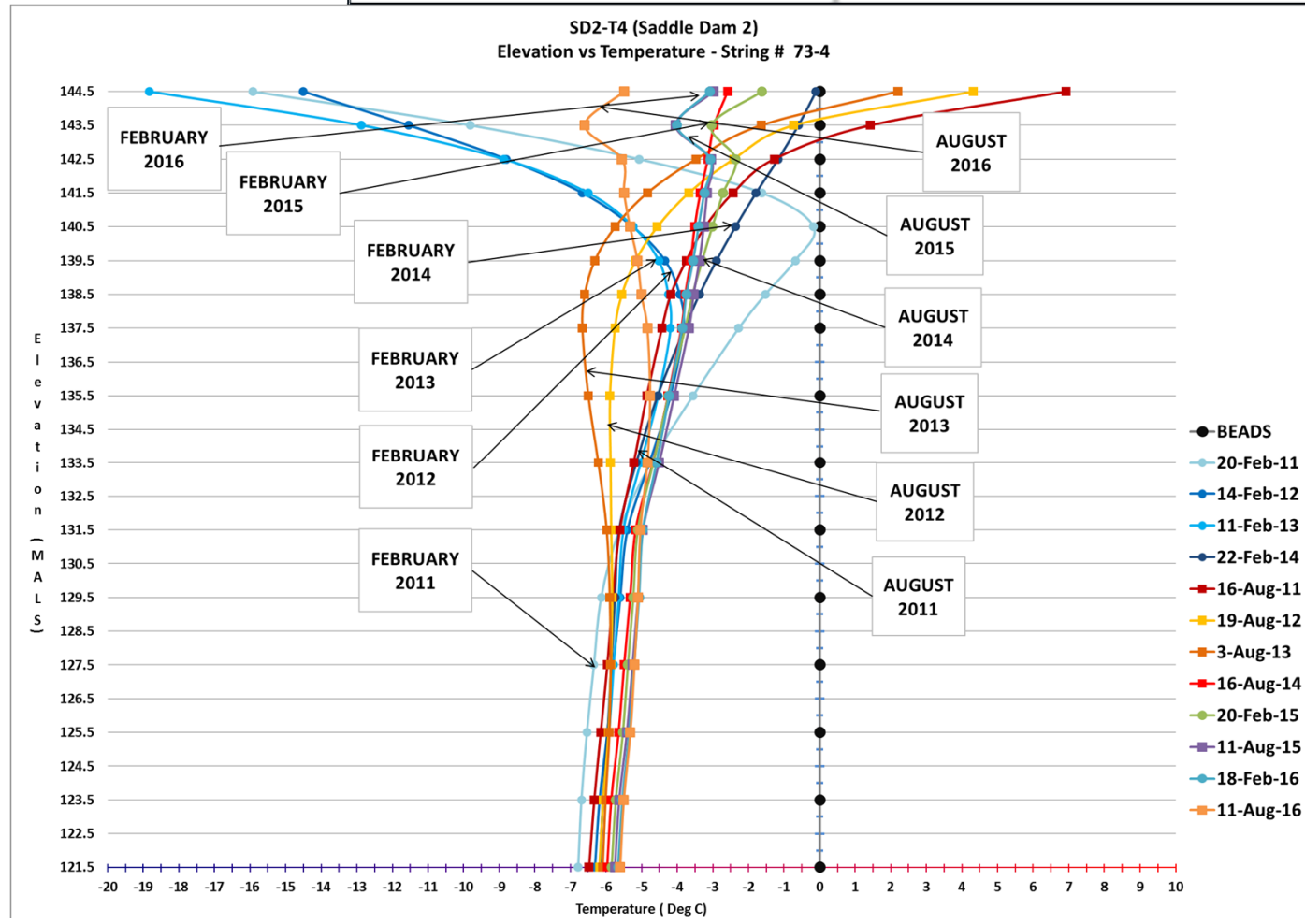
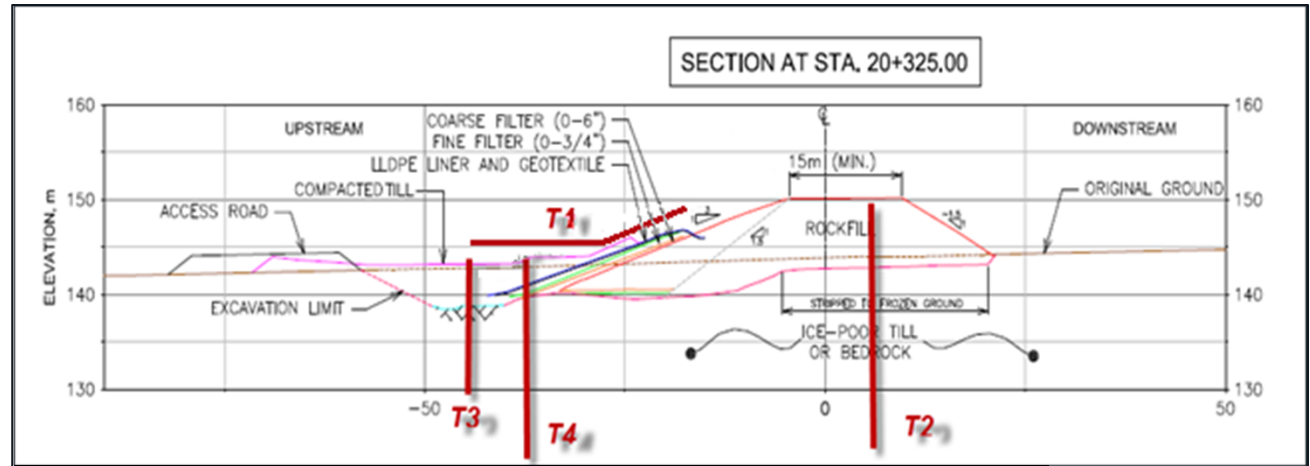

SADDLE DAM 2

- T4

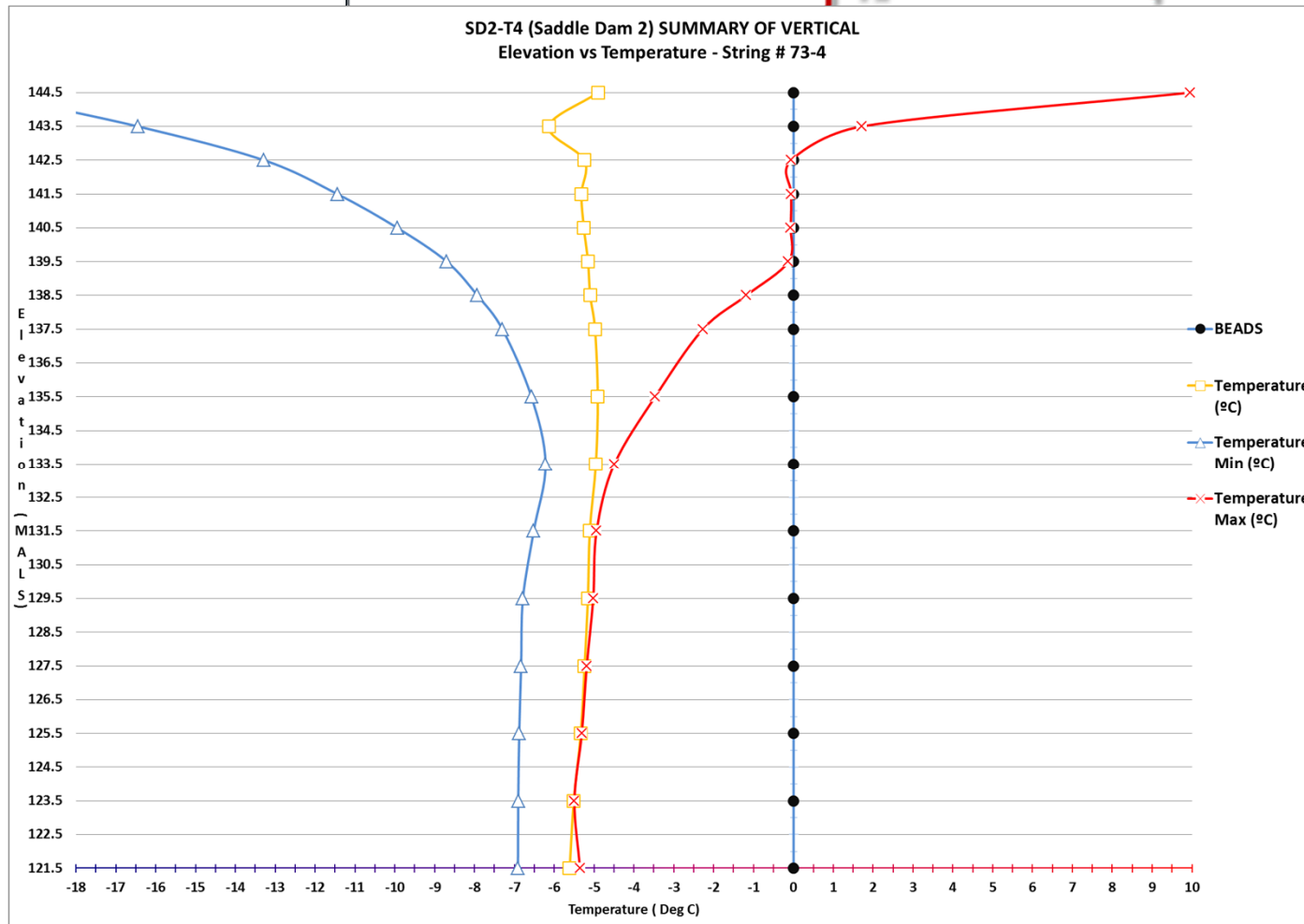
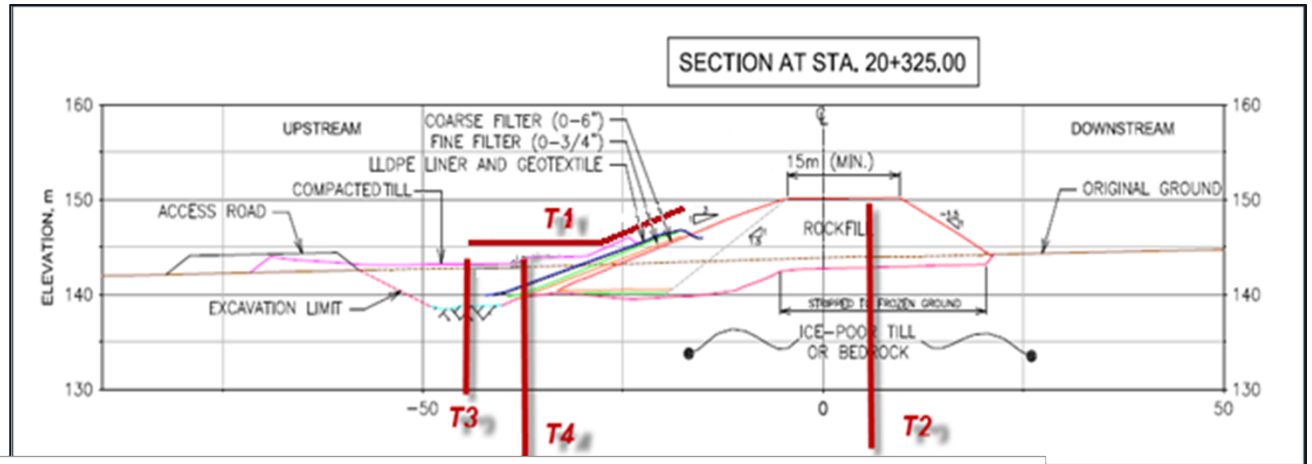

STORMWATER – REVIEW OF INSTRUMENTATION

- Piezo – 1 Total **P 13265**
- Thermistor – 1 Total **T147-1**



STORMWATER - T147-1

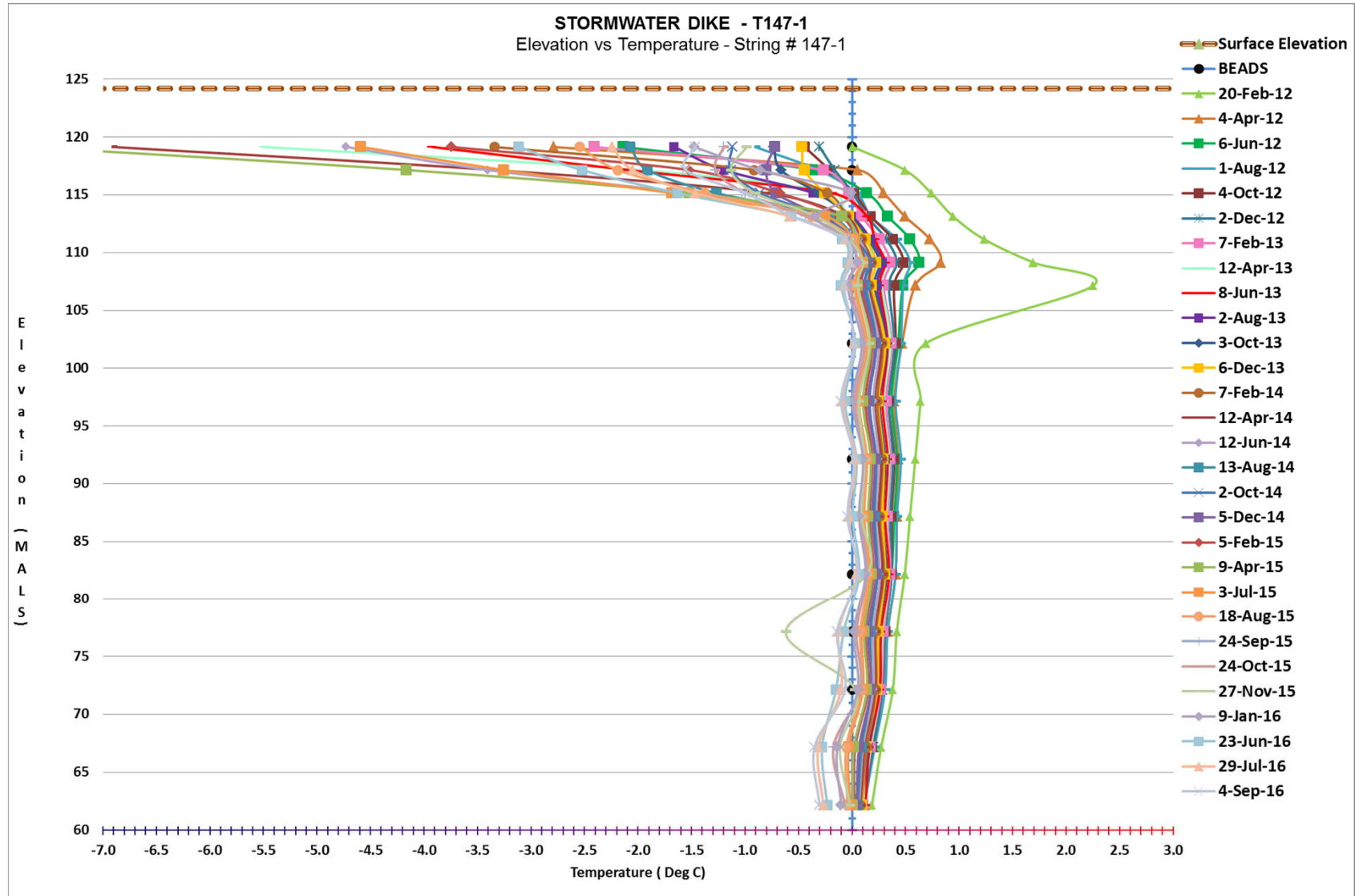

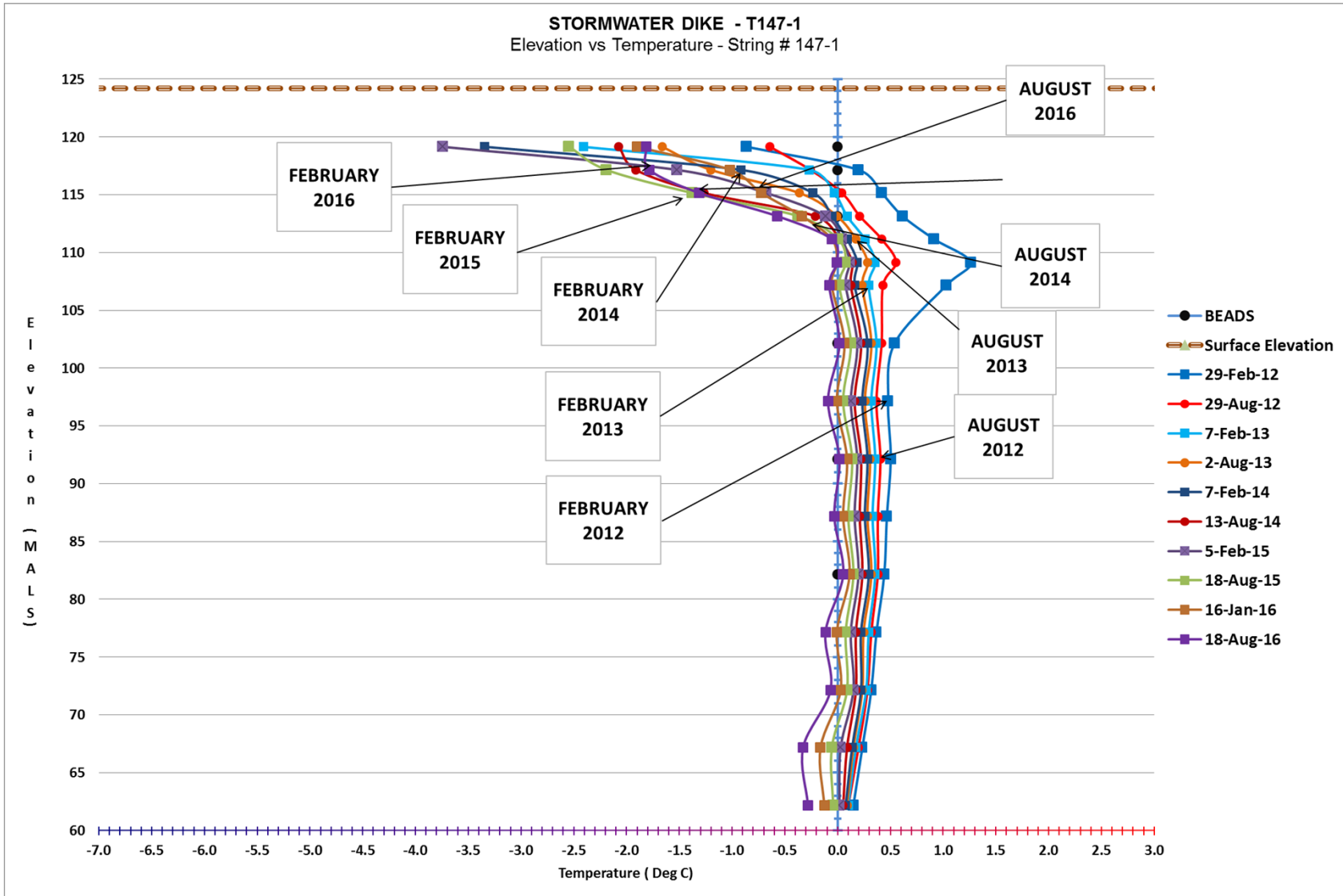

STORMWATER - VWP 13265

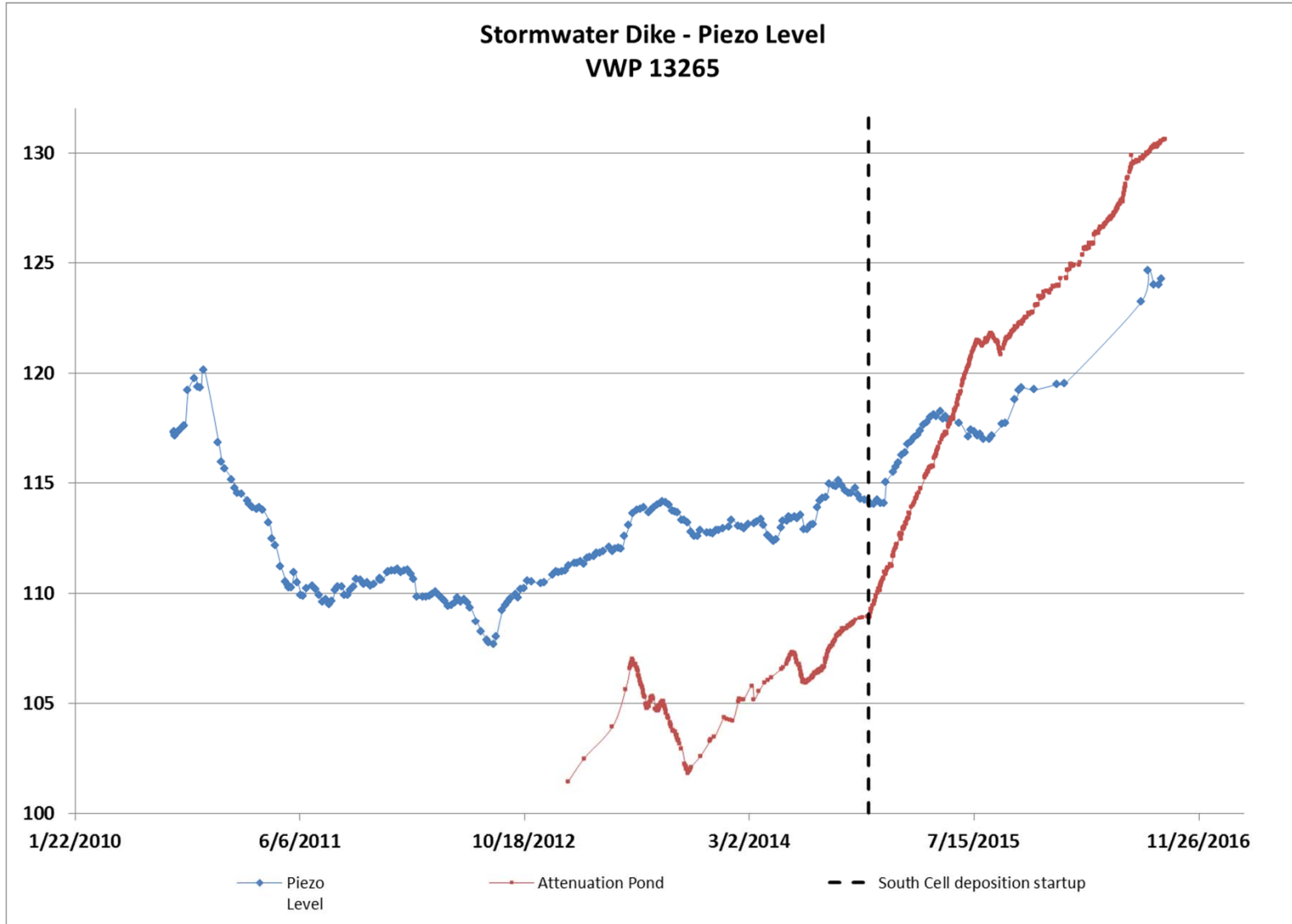

RF1 AND RF2 – REVIEW OF INSTRUMENTATION

- **RF 1 Thermistor – 3 Total T121-1, T122-1, RF1-3 and T73-6**

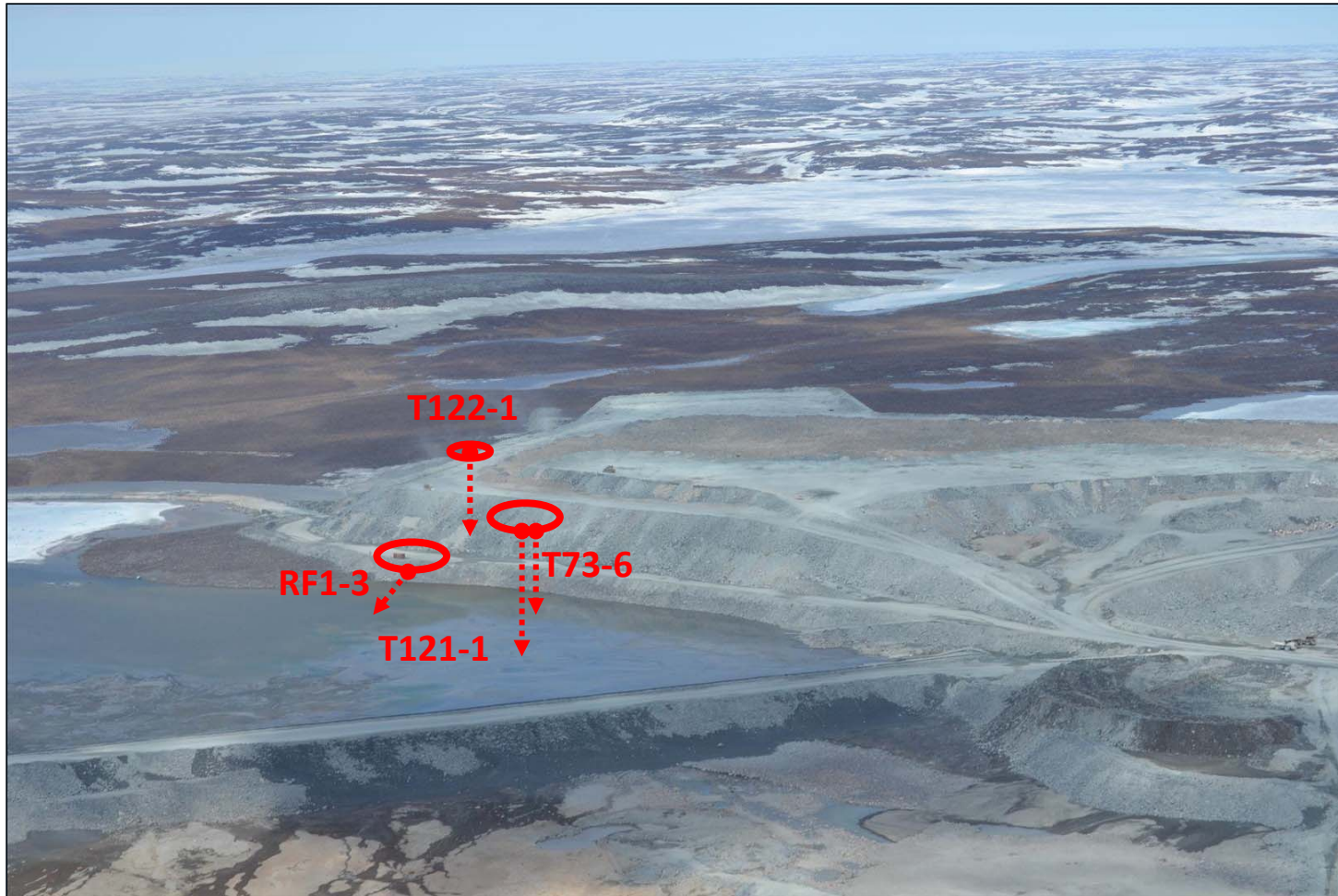

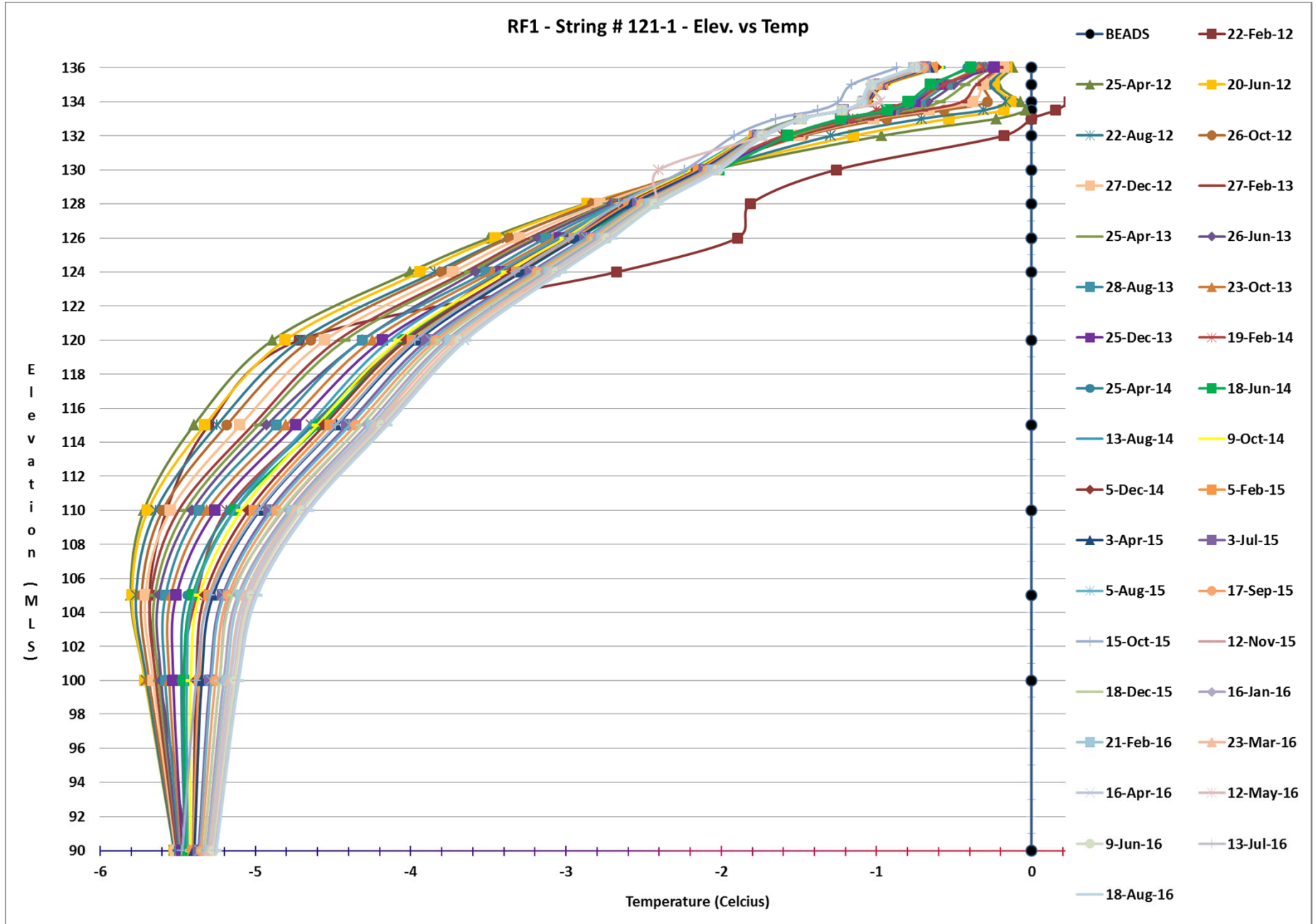

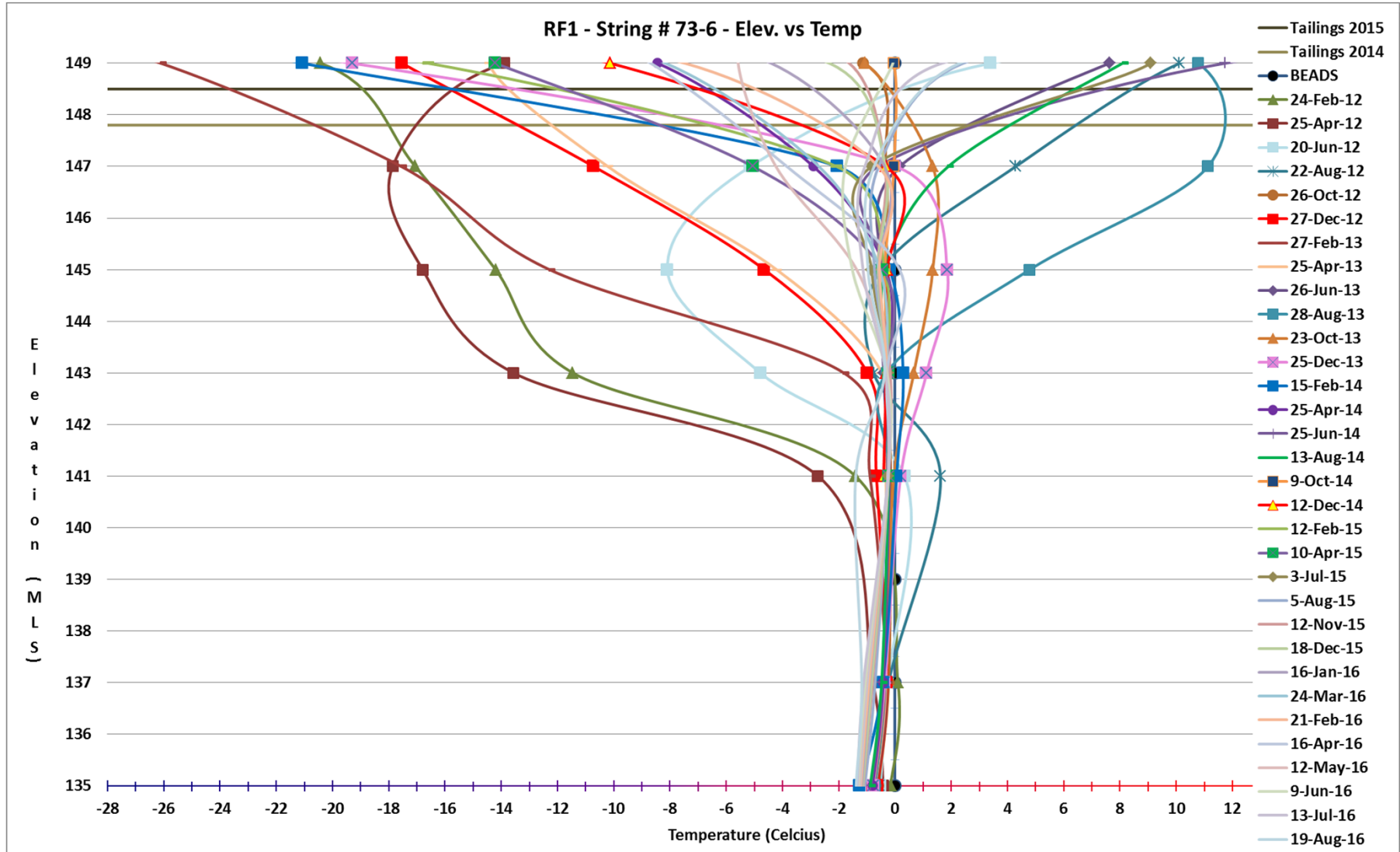

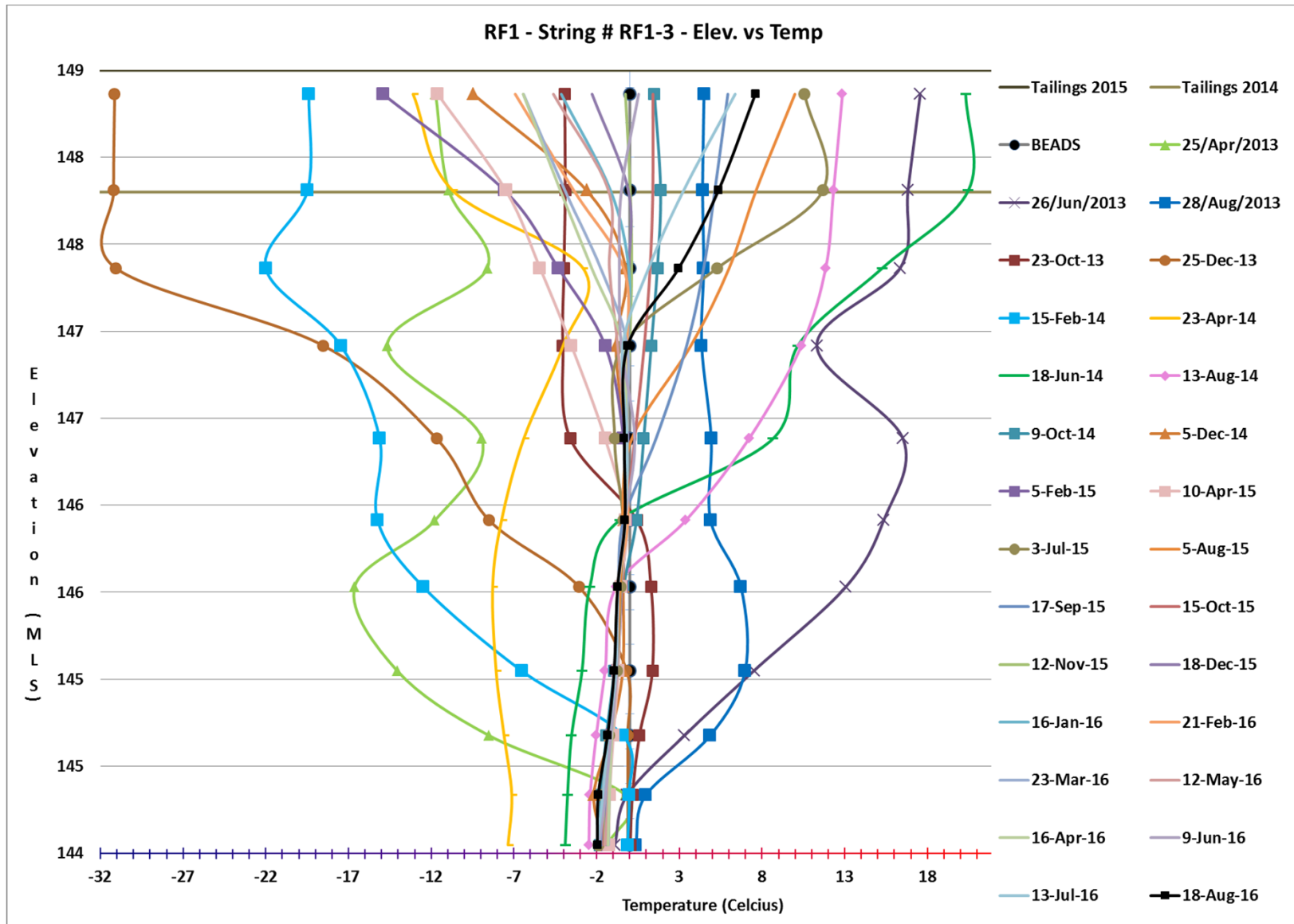

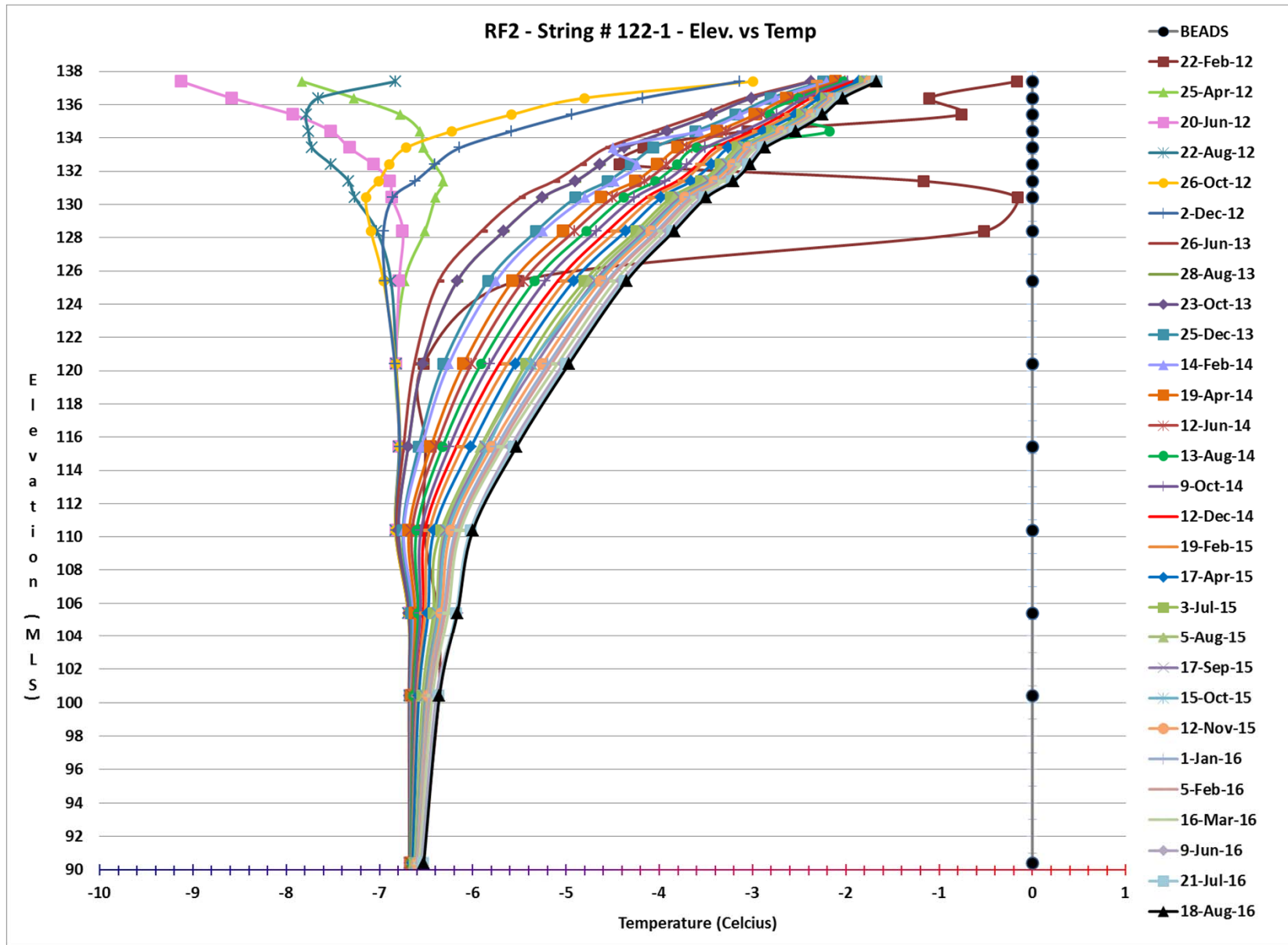

THERMISTORS INSIDE THE TAILINGS

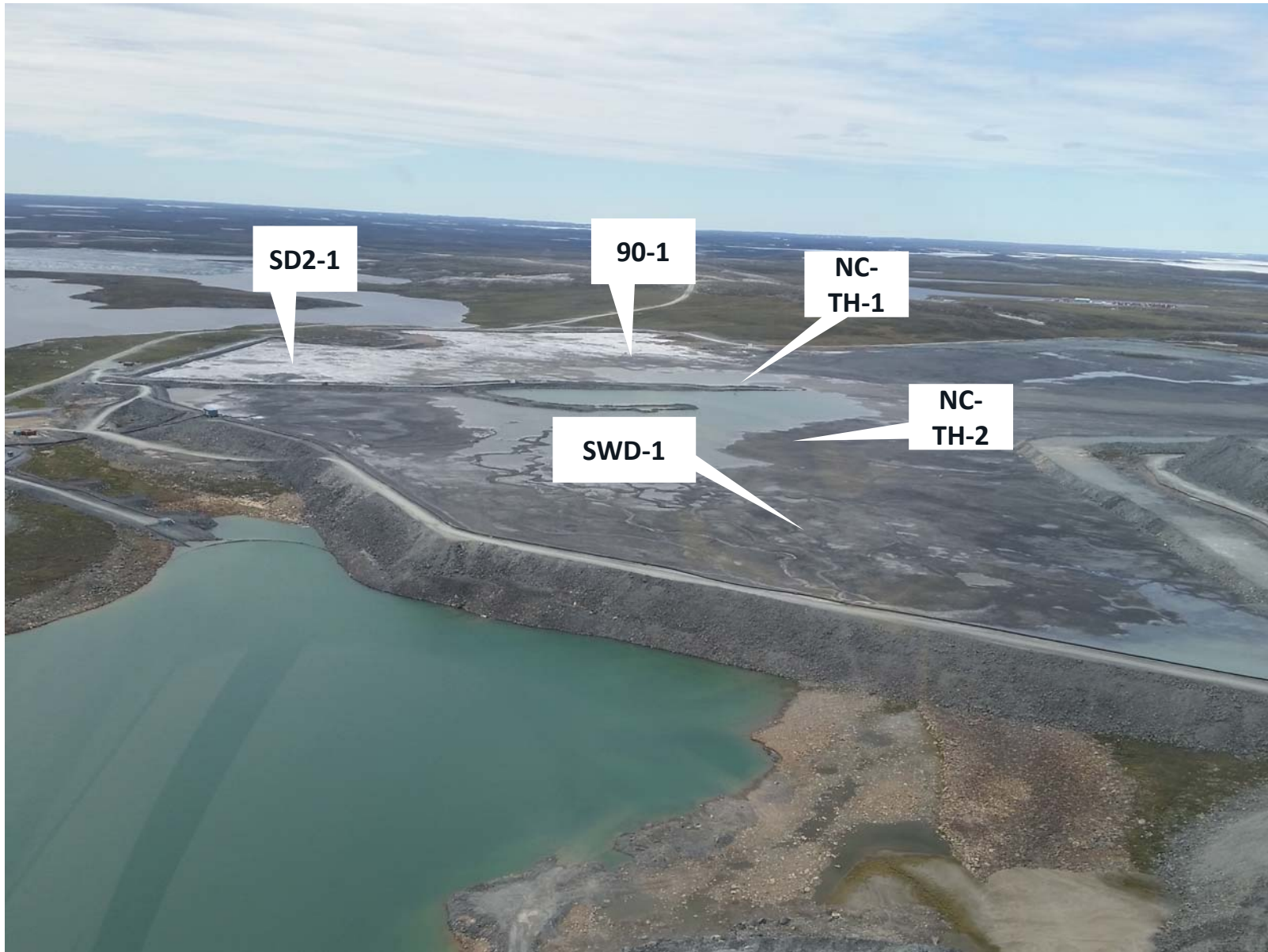

THERMISTOR SD2-1



AGNICO EAGLE

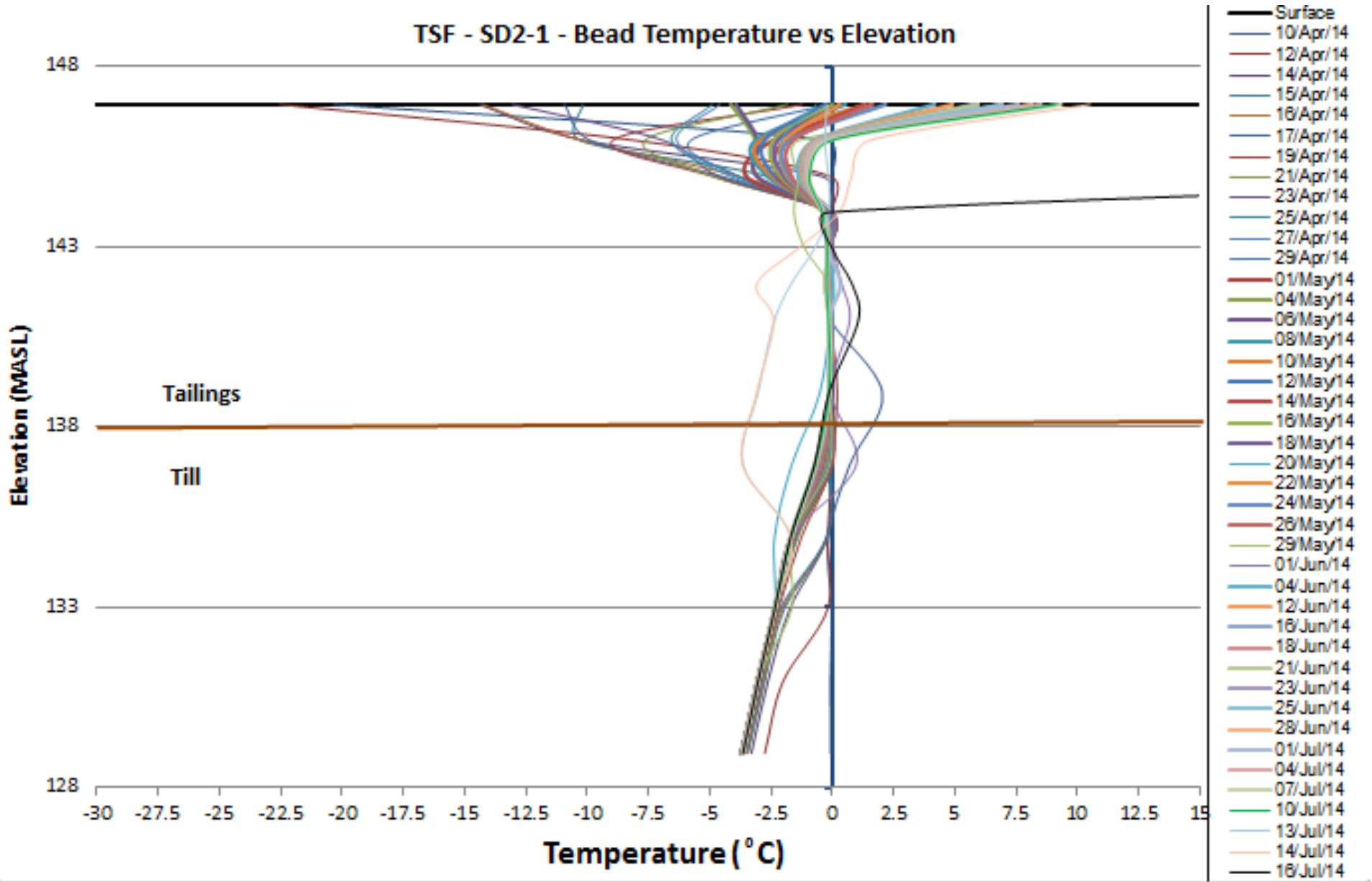

THERMISTOR SWD-1



TSF - SWD-1 - Bead Temperature vs Elevation

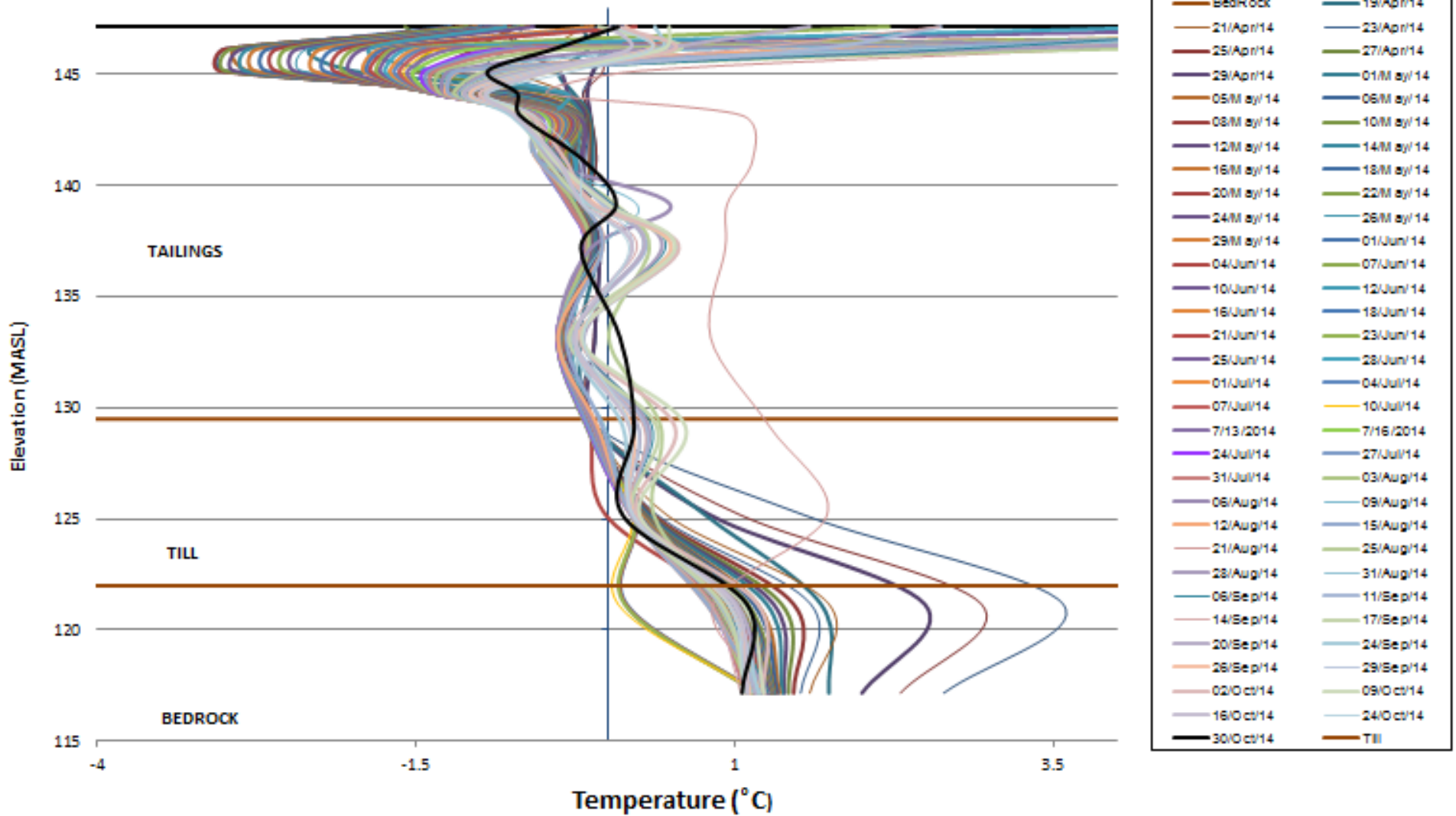



THERMISTOR 90-1 (SD-1)

TH 90-1 (Saddle Dam 1)

Elevation vs Temperature - String #90-1 . Into the tailings

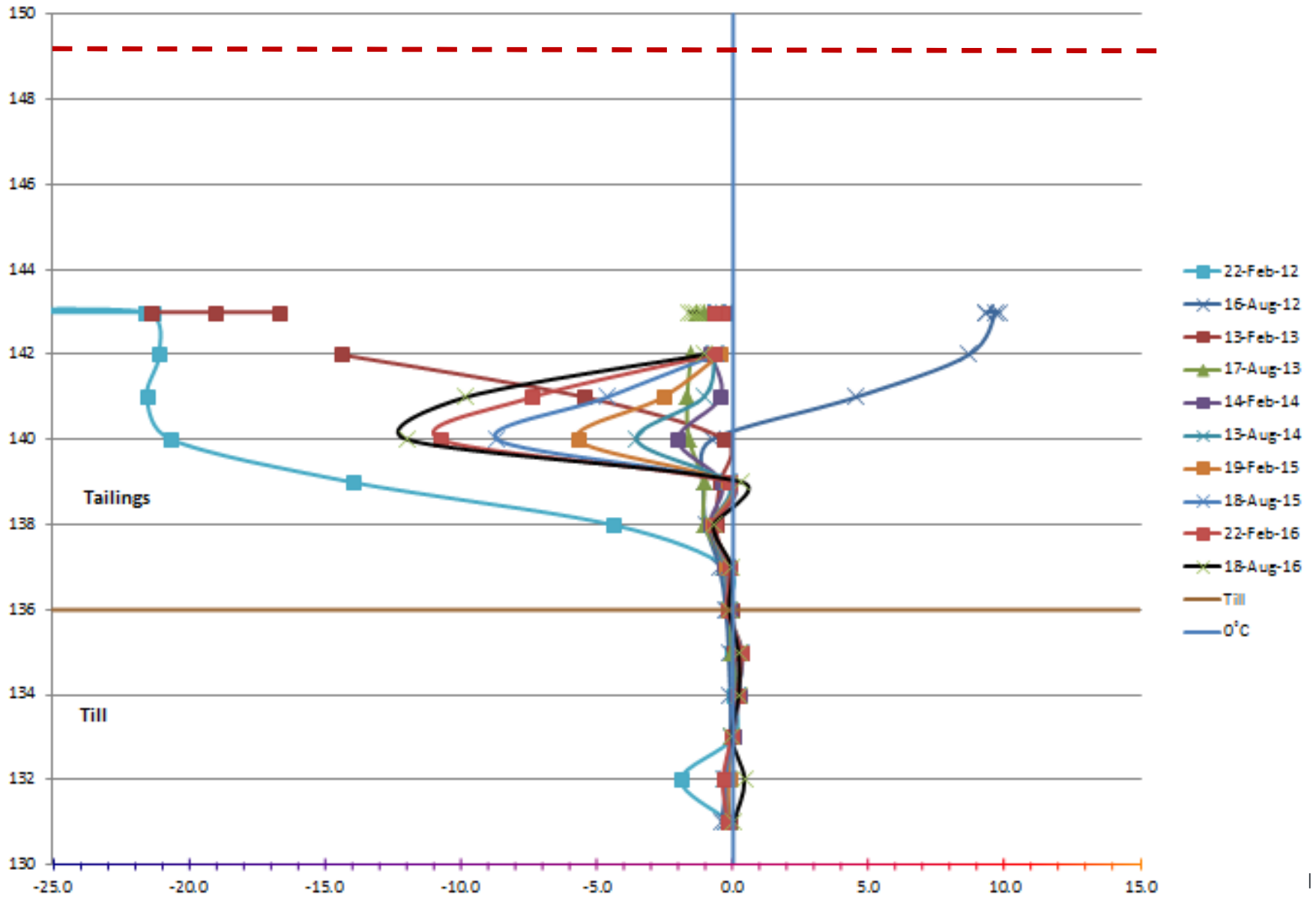

THERMISTOR NC-T1



TSF North Cell (NC-T1) - Bead Temperature vs Elevation

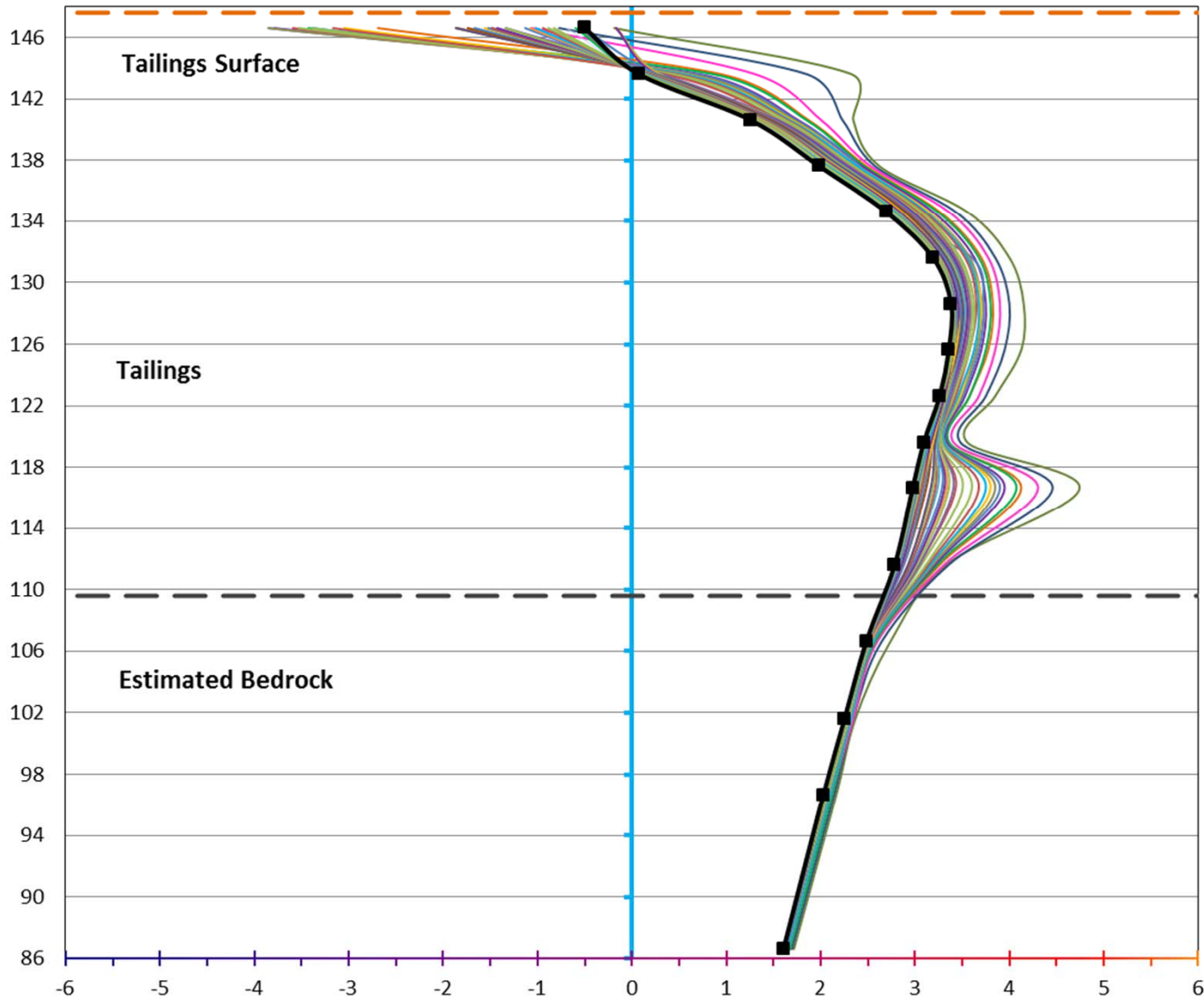

- - Tailings Surface
- - Bedrock
- 27/Apr/16
- 29/Apr/16
- 30/Apr/16
- 02/May/16
- 03/May/16
- 05/May/16
- 06/May/16
- 07/May/16
- 08/May/16
- 09/May/16
- 11/May/16
- 13/May/16
- 16/May/16
- 20/May/16
- 22/May/16
- 24/May/16
- 26/May/16
- 28/May/16
- 30/May/16
- 03/June/16
- 07/June/16
- 11/June/16
- 13/June/16
- 22/June/16
- 26/June/16
- 03/July/16
- 06/July/16
- 09/July/16
- 12/July/16
- 17/July/16
- 29/July/16
- 01/Aug/16
- 04/Aug/16
- 08/Aug/16
- 11/Aug/16
- 14/Aug/16
- 23/Aug/16
- 01/Sep/16
- 05/Sep/16
- 08/Sep/16
- 11/Sep/16

THERMISTOR NC-T2

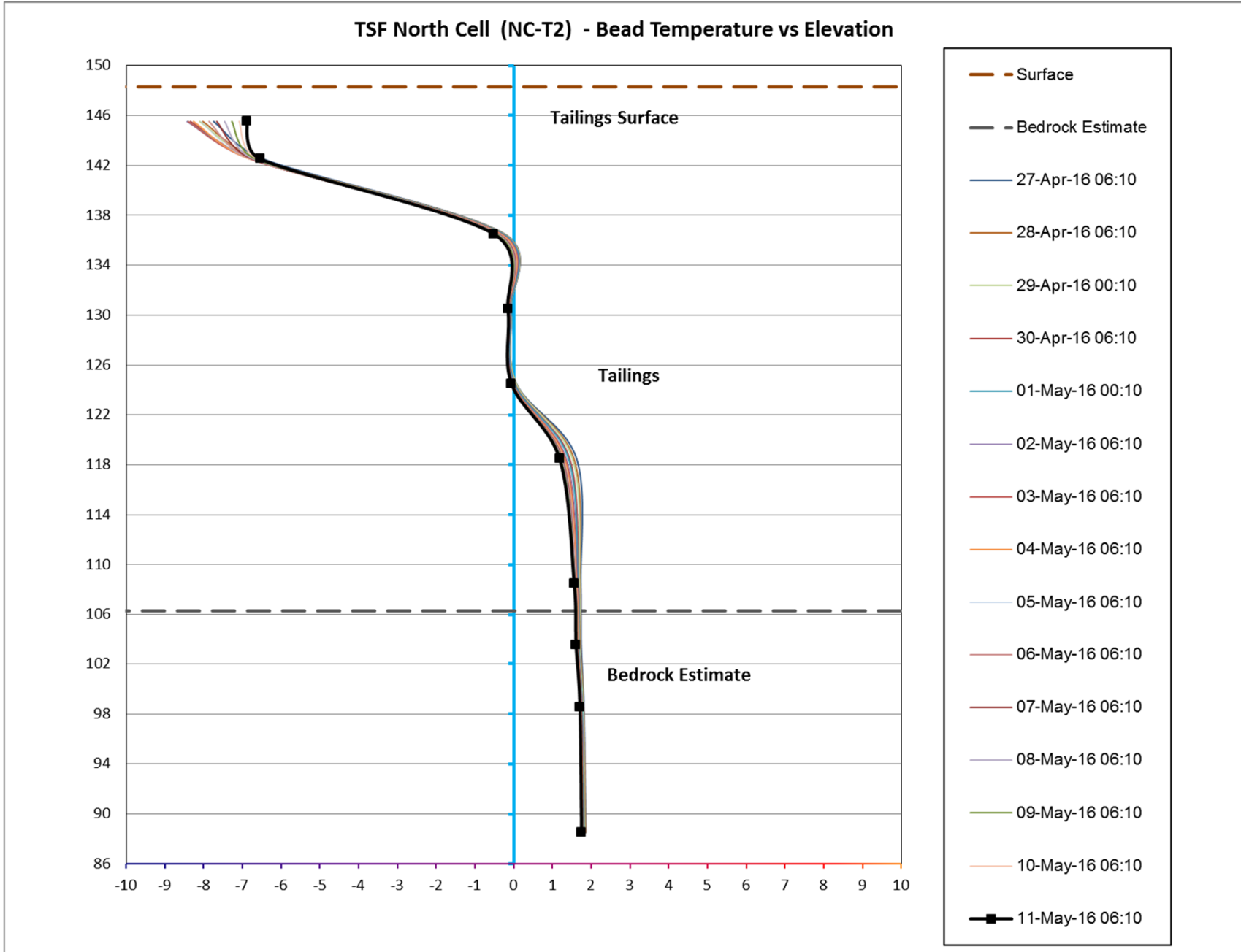

CONCLUSION



- Foundation of most of the North Cell structures remains frozen almost all year long
- Tailings into the cell is not entirely frozen, likely frozen around the structure but not in the talik area where the reclaim pond was kept during operation
- With results of the thermal monitoring in the North Cell, more instruments needs to be installed to have a better idea of the temperature distribution within the North Cell.
- An instrumentation program will be done next winter with the purpose of gathering more info on the temperature of the tailings
- 8 TH will be installed and monitored with dataloggers in selected locations

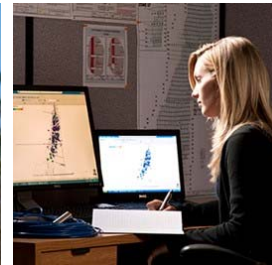

Trading Symbol:
AEM on TSX & NYSE

Investor Relations:
416-847-8665
info@agnicoeagle.com

agnicoeagle.com





APPENDIX D

All-Weather Private Road



APPENDIX D1

Culverts Photographic Log



APPENDIX D1 CULVERTS PHOTOGRAPHIC LOG



Photograph D1-1: PRC1 km 0+430

Date: September 10, 2016

Photo Number: 186

Description: View of culvert inlet, in good condition no sign of obstruction.



Photograph D1-2: PRC1 km 0+430

Date: September 10, 2016

Photo Number: 187

Description: View of culvert outlet. The outlet is slightly damaged and obstructed. The culvert is still functional and in overall good condition.



APPENDIX D1 CULVERTS PHOTOGRAPHIC LOG



Photograph D1-3: PRC2 km 0+470

Date: September 10, 2016

Photo Number: 184

Description: View of culverts inlet. In good condition.



Photograph D1-4: PRC2 km 0+470

Date: September 10, 2016

Photo Number: 185

Description: View of culverts outlet. In good condition.



APPENDIX D1 CULVERTS PHOTOGRAPHIC LOG



Photograph D1-5: PRC3 km 1+380

Date: September 10, 2016

Photo Number: 182

Description: View of culvert inlet. In good condition.



Photograph D1-6: PRC3 km 1+380

Date: September 10, 2016

Photo Number: 183

Description: View of culvert outlet. In good condition.



APPENDIX D1 CULVERTS PHOTOGRAPHIC LOG



Photograph D1-7: R-00A km 2+550

Date: September 10, 2016

Photo Number: 180

Description: View of culvert inlet. The inlet is partially collapsed. No sign of flow.



Photograph D1-8: R-00A km 2+550

Date: September 10, 2016

Photo Number: 181

Description: View of culvert outlet. The outlet is collapsed and the road bed cover is too thin to provide protection. No sign of flow.



APPENDIX D1 CULVERTS PHOTOGRAPHIC LOG



Photograph D1-9: PC-14 km 4+260

Date: September 10, 2016

Photo Number: 178

Description: View of the culverts inlet. Culverts is too damaged to be functional.



Photograph D1-10: PC-14 km 4+260

Date: September 10, 2016

Photo Number: 179

Description: View of the culverts outlet. These two culverts are no longer functional.



APPENDIX D1 CULVERTS PHOTOGRAPHIC LOG



Photograph D1-11: unnamed km 5+700

Date: September 10, 2016

Photo Number: 174

Description: View of the culvert inlet. Good condition, inlet is short in length as the road rolling surface is at the edge of the inlet.



Photograph D1-12: unnamed km 5+700

Date: September 10, 2016

Photo Number: 175

Description: View of the culvert outlet. Outlet partially buried in gravel.



APPENDIX D1 CULVERTS PHOTOGRAPHIC LOG



Photograph D1-13: PC-17A km 8+830

Date: September 10, 2016

Photo Number: 167

Description: View of the culverts inlet. Sign of erosion and flow of water beneath the inlet.



Photograph D1-14: PC-17A km 8+830

Date: September 10, 2016

Photo Number: 168

Description: View of the culverts outlet (left side of the picture). The culverts were installed too high. Sign of erosion, flow of water beneath the culverts and deterioration.



APPENDIX D1 CULVERTS PHOTOGRAPHIC LOG



Photograph D1-15: PC-17 km 8+850

Date: September 10, 2016

Photo Number: 166

Description: View of the culverts inlet. Good condition.



Photograph D1-16: PC-17 km 8+850

Date: September 10, 2016

Photo Number: 169

Description: View of the culverts outlet (right side of the picture). Good condition.



APPENDIX D1 CULVERTS PHOTOGRAPHIC LOG



Photograph D1-17: PC-1 km 9+952

Date: September 10, 2016

Photo Number: 164

Description: View of the culvert inlet. In good condition.



Photograph D1-18: PC-1 km 9+952

Date: September 10, 2016

Photo Number: 165

Description: View of the culvert outlet. In good condition.



APPENDIX D1 CULVERTS PHOTOGRAPHIC LOG



Photograph D1-19: R-03 km 10+580

Date: September 10, 2016

Photo Number: 162

Description: View of the culvert inlet. In good condition.



Photograph D1-20: R-03 km 10+580

Date: September 10, 2016

Photo Number: 163

Description: View of the culvert outlet. In good condition.



APPENDIX D1 CULVERTS PHOTOGRAPHIC LOG



Photograph D1-21: R-04 km 12+050

Date: September 10, 2016

Photo Number: 160

Description: View of the culvert inlet. In good condition.



Photograph D1-22: R-04 km 12+050

Date: September 10, 2016

Photo Number: 161

Description: View of the culvert outlet. In good condition.



APPENDIX D1 CULVERTS PHOTOGRAPHIC LOG



Photograph D1-23: PC-13 km 12+745

Date: September 10, 2016

Photo Number: 158

Description: View of the culvert inlet. In good condition.



Photograph D1-24: PC-13 km 12+745

Date: September 10, 2016

Photo Number: 159

Description: View of the culvert outlet. In good condition.



APPENDIX D1 CULVERTS PHOTOGRAPHIC LOG



Photograph D1-25: PC-2 km 13+405

Date: September 10, 2016

Photo Number: 153

Description: View of the culvert inlet. In good condition.



Photograph D1-26: PC-2 km 13+405

Date: September 10, 2016

Photo Number: 154

Description: View of the culvert outlet. In good condition.



APPENDIX D1 CULVERTS PHOTOGRAPHIC LOG



Photograph D1-27: PC-3 km 13+685

Date: September 10, 2016

Photo Number: 151

Description: View of the culvert inlet. In good condition.



Photograph D1-28: PC-3 km 13+685

Date: September 10, 2016

Photo Number: 152

Description: View of the culvert outlet. In good condition.



APPENDIX D1 CULVERTS PHOTOGRAPHIC LOG



Photograph D1-29: unnamed km 13+950

Date: September 10, 2016

Photo Number: 149

Description: View of the culvert inlet. In good condition.



Photograph D1-30: unnamed km 13+950

Date: September 10, 2016

Photo Number: 150

Description: View of the culvert outlet. The outlet is in good condition.



APPENDIX D1 CULVERTS PHOTOGRAPHIC LOG



Photograph D1-31: PC-4 km 14+910

Date: September 10, 2016

Photo Number: 147

Description: View of the culvert inlet. In good condition.



Photograph D1-32: PC-4 km 14+910

Date: September 10, 2016

Photo Number: 148

Description: View of the culvert outlet. In good condition. Large boulders around the outlet.



APPENDIX D1 CULVERTS PHOTOGRAPHIC LOG



Photograph D1-33: R-05A km 15+745

Date: September 10, 2016

Photo Number: 145

Description: View of the culvert inlet. In good condition.



Photograph D1-34: R-05A km 15+745

Date: September 10, 2016

Photo Number: 146

Description: View of the culvert outlet. In good condition.



APPENDIX D1 CULVERTS PHOTOGRAPHIC LOG



Photograph D1-35: PC-5 km 18+280

Date: September 10, 2016

Photo Number: 139

Description: View of the culvert inlet. In good condition.



Photograph D1-36: PC-5 km 18+280

Date: September 10, 2016

Photo Number: 140

Description: View of the culvert outlet. In good condition.



APPENDIX D1 CULVERTS PHOTOGRAPHIC LOG



Photograph D1-37: PC-6 km 18+900

Date: September 10, 2016

Photo Number: 137

Description: View of culvert inlet. In good condition.



Photograph D1-38: PC-6 km 18+900

Date: September 10, 2016

Photo Number: 138

Description: View of culvert outlet. In good condition.



APPENDIX D1 CULVERTS PHOTOGRAPHIC LOG



Photograph D1-39: PC-7A km 20+240

Date: September 10, 2016

Photo Number: 135

Description: View of culverts inlet. Inlet of southern culvert partially obstructed.



Photograph D1-40: PC-7A km 20+240

Date: September 10, 2016

Photo Number: 136

Description: View of culverts outlet. Outlet of northern culvert damaged.



APPENDIX D1 CULVERTS PHOTOGRAPHIC LOG



Photograph D1-41: PC-7 km 20+250

Date: September 10, 2016

Photo Number: 133

Description: View of the culvert inlet. In good condition.



Photograph D1-42: PC-7 km 20+250

Date: September 10, 2016

Photo Number: 134

Description: View of the culvert outlet. In good condition.



APPENDIX D1 CULVERTS PHOTOGRAPHIC LOG



Photograph D1-43: R-07 km 25+900

Date: September 10, 2016

Photo Number: 127

Description: View of the culvert inlet. In good condition.



Photograph D1-44: R-07 km 25+900

Date: September 10, 2016

Photo Number: 128

Description: View of the culvert outlet. In good condition.



APPENDIX D1 CULVERTS PHOTOGRAPHIC LOG



Photograph D1-45: PC-8 km 29+420

Date: September 10, 2016

Photo Number: 125

Description: View of the culvert inlet. In good condition.



Photograph D1-46: PC-8 km 29+420

Date: September 10, 2016

Photo Number: 126

Description: View of the culvert outlet. In good condition.



APPENDIX D1 CULVERTS PHOTOGRAPHIC LOG



Photograph D1-47: PC-9 km 35+690

Date: September 10, 2016

Photo Number: 119

Description: View of the culvert inlet. In good condition.



Photograph D1-48: PC-9 km 35+690

Date: September 10, 2016

Photo Number: 120

Description: View of the culvert outlet. In good condition.



APPENDIX D1 CULVERTS PHOTOGRAPHIC LOG



Photograph D1-49: PC-10 km 36+865

Date: September 10, 2016

Photo Number: 115

Description: View of the culvert inlet. In good condition.



Photograph D1-50: PC-10 km 36+865

Date: September 10, 2016

Photo Number: 116

Description: View of the culvert outlet. In good condition.



APPENDIX D1 CULVERTS PHOTOGRAPHIC LOG



Photograph D1-51: PC-11 km 39+552

Date: September 10, 2016

Photo Number: 113

Description: View of the culvert inlet. In good condition.



Photograph D1-52: PC-11 km 39+552

Date: September 10, 2016

Photo Number: 114

Description: View of the culvert outlet. In good condition, almost submerged.



APPENDIX D1 CULVERTS PHOTOGRAPHIC LOG



Photograph D1-53: PC-12 km 41+300

Date: September 10, 2016

Photo Number: 109

Description: View of the culvert inlet. In good condition, almost submerged.



Photograph D1-54: PC-12 km 41+300

Date: September 10, 2016

Photo Number: 110

Description: View of the culvert outlet. In good condition, almost submerged.



APPENDIX D1 CULVERTS PHOTOGRAPHIC LOG



Photograph D1-55: R-14 km 67+840

Date: September 10, 2016

Photo Number: 87

Description: View of the inlet culverts. Middle and northern culverts are collapsed inside (hole in the middle). Expected to continue performing well.



Photograph D1-56: R-14 km 67+840

Date: September 10, 2016

Photo Number: 88

Description: View of the outlet culverts. The middle and northern culverts show small signs of erosion at the outlet and these culverts are collapsed inside (hole in the middle). Expected to continue performing well.



APPENDIX D1 CULVERTS PHOTOGRAPHIC LOG



Photograph D1-57: R-17 km 77+440

Date: September 10, 2016

Photo Number: 75

Description: View of the culvert inlet. In good condition.



Photograph D1-58: R-17 km 77+440

Date: September 10, 2016

Photo Number: 76

Description: View of the culvert outlet. In good condition.



APPENDIX D1 CULVERTS PHOTOGRAPHIC LOG



Photograph D1-59: R-18A km 80+950

Date: September 10, 2016

Photo Number: 70

Description: View of the culverts inlet. In good condition. The southern culvert inlet is partially buried.



Photograph D1-60: R-18A km 80+950

Date: September 10, 2016

Photo Number: 69

Description: View of the culverts outlet. In good condition.



APPENDIX D1 CULVERTS PHOTOGRAPHIC LOG



Photograph D1-61: R-18B km 80+950

Date: September 10, 2016

Photo Number: 68

Description: View of the culverts inlet. In good condition, installed above the ground surface.

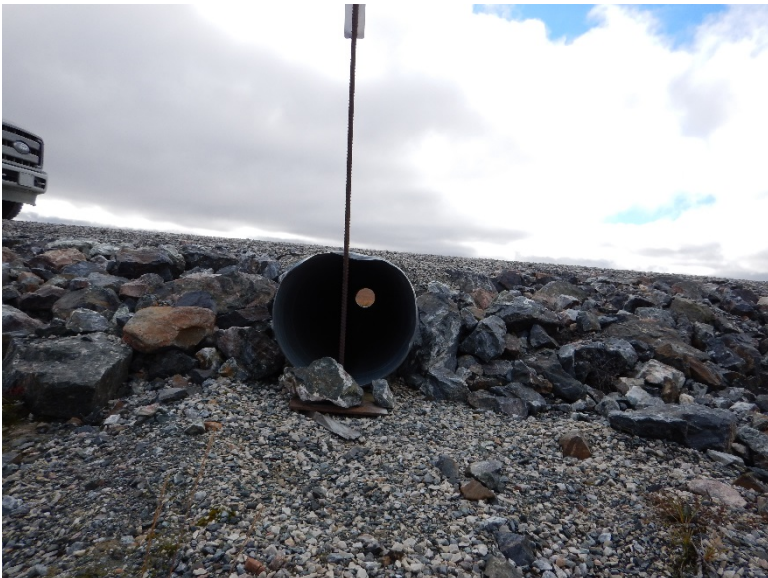

Photograph D1-62: R-18B km 80+950

Date: September 10, 2016

Photo Number: 67

Description: View of the culverts outlet. In good condition, installed above the ground surface.



APPENDIX D1 CULVERTS PHOTOGRAPHIC LOG



Photograph D1-63: R-20 km 85+490

Date: September 10, 2016

Photo Number: 59

Description: View of the culvert inlet. The middle of the culvert is slightly collapsed. The inlet is installed above the ground surface and water flows beneath the culvert. The culvert is in stable condition.



Photograph D1-64: R-20 km 85+490

Date: September 10, 2016

Photo Number: 60

Description: View of the culvert outlet. Outlet is a little bit twisted. The middle of the culvert is slightly collapsed. Water flows beneath the culvert. The culvert is in stable condition.



APPENDIX D1 CULVERTS PHOTOGRAPHIC LOG



Photograph D1-65: R-21 km 87+300

Date: September 10, 2016

Photo Number: 57

Description: View of the culverts inlet. Both culverts are slightly collapsed in the middle. In stable condition, but should have been installed lower to avoid erosion issue.



Photograph D1-66: R-21 km 87+300

Date: September 10, 2016

Photo Number: 58

Description: View of the culverts outlet. Both culverts are slightly collapsed in the middle. In stable condition, but should have been installed lower to avoid erosion issue.



APPENDIX D1 CULVERTS PHOTOGRAPHIC LOG



Photograph D1-67: R-23 km 93+600

Date: September 10, 2016

Photo Number: 51

Description: View of the culvert inlet. The culvert is installed too high and there is a low flow of water through the road rockfill. In good condition.



Photograph D1-68: R-23 km 93+600

Date: September 10, 2016

Photo Number: 52

Description: View of the culvert outlet. The culvert is installed too high and there is a low flow of water through the road rockfill. In good condition.



APPENDIX D1 CULVERTS PHOTOGRAPHIC LOG



Photograph D1-69: R-24 km 98+100

Date: September 10, 2016

Photo Number: 49

Description: View of the culverts inlet. South inlet is installed too high. Both culverts show deformation in the upper part.



Photograph D1-70: R-24 km 98+100

Date: September 10, 2016

Photo Number: 50

Description: View of the culverts outlet. Both outlets are installed too high. The outlet of the southern culvert (left) shows signs of erosion. Both culverts show deformation in the upper part.



APPENDIX D1 CULVERTS PHOTOGRAPHIC LOG



Photograph D1-71: R-25 km 101+950

Date: September 10, 2016

Photo Number: 45

Description: View of the culverts inlet. In good condition.



Photograph D1-72: R-25 km 101+950

Date: September 10, 2016

Photo Number: 46

Description: View of the culverts outlet. In good condition.



APPENDIX D1 CULVERTS PHOTOGRAPHIC LOG



Photograph D1-73: R-26 km 104+400

Date: September 10, 2016

Photo Number: 43

Description: View of the culverts outlet. In good condition.



Photograph D1-74: R-26 km 104+400

Date: September 10, 2016

Photo Number: 44

Description: View of the culverts inlet. In good condition. Presence of a 0.4 m boulder in front of the west inlet. In good condition.

n:\actif\2016\3 proj\1662181 aem geotech insp 2016 meadowbank\5 preparation of deliverables\doc 1549 2016 geotechnical inspection\rev 0\3 appendices\appendix d - awpr\d1 culverts\d1 - culverts photo log 2016.docx



APPENDIX D2

Bridges Photographic Log



APPENDIX D2 BRIDGES PHOTOGRAPHIC LOG



Photograph D2-1 Bridges 1 – R02 km 8+750

Date: September 10, 2016

Photo Number: 170

Description: Looking at the north abutment from downstream.



Photograph D2-2 Bridges 1 – R02 km 8+750

Date: September 10, 2016

Photo Number: 171

Description: Looking at the south abutment from downstream.



APPENDIX D2 BRIDGES PHOTOGRAPHIC LOG



Photograph D2-3 Bridges 1 – R02 km 8+750

Date: September 10, 2016

Photo Number: 172

Description: Looking at the north abutment from upstream.



Photograph D2-4 Bridges 1 – R02 km 8+750

Date: September 10, 2016

Photo Number: 173

Description: Looking at the south abutment from upstream.



APPENDIX D2 BRIDGES PHOTOGRAPHIC LOG



Photograph D2-5 Bridges 2 – R05 km 17+600

Date: September 10, 2016

Photo Number: 144

Description: Looking at the north abutment from downstream.



Photograph D2-6 Bridges 2 – R05 km 17+600

Date: September 10, 2016

Photo Number: 143

Description: Looking at the south abutment from downstream. Minor damage to the bin wall.



APPENDIX D2 BRIDGES PHOTOGRAPHIC LOG



Photograph D2-7 Bridges 2 – R05 km 17+600

Date: September 10, 2016

Photo Number: 142

Description: Looking at the north abutment from upstream.



Photograph D2-8 Bridges 2 – R05 km 17+600

Date: September 10, 2016

Photo Number: 141

Description: Looking at the south abutment from upstream. Minor damage to the bin wall.



APPENDIX D2 BRIDGES PHOTOGRAPHIC LOG



Photograph D2-9 Bridges 3 – R06 km 23+100

Date: September 10, 2016

Photo Number: 131

Description: Looking at the bridge from the west side.



Photograph D2-10 Bridges 3 – R06 km 23+100

Date: September 10, 2016

Photo Number: 132

Description: Looking at the bridge from the east side.



APPENDIX D2 BRIDGES PHOTOGRAPHIC LOG



Photograph D2-11 Bridges 4 – R09 km 48+500

Date: September 10, 2016

Photo Number: 103

Description: Looking at the bridge from the west side.



Photograph D2-12 Bridges 4 – R09 km 48+500

Date: September 10, 2016

Photo Number: 104

Description: Looking at the bridge from the east side.



APPENDIX D2 BRIDGES PHOTOGRAPHIC LOG



Photograph D2-13 Bridges 5 – R13 km 62+060

Date: September 10, 2016

Photo Number: 95

Description: Looking at the bridge from the west side.



Photograph D2-14 Bridges 5 – R13 km 62+060

Date: September 10, 2016

Photo Number: 96

Description: Looking at the bridge from the east side.



APPENDIX D2 BRIDGES PHOTOGRAPHIC LOG

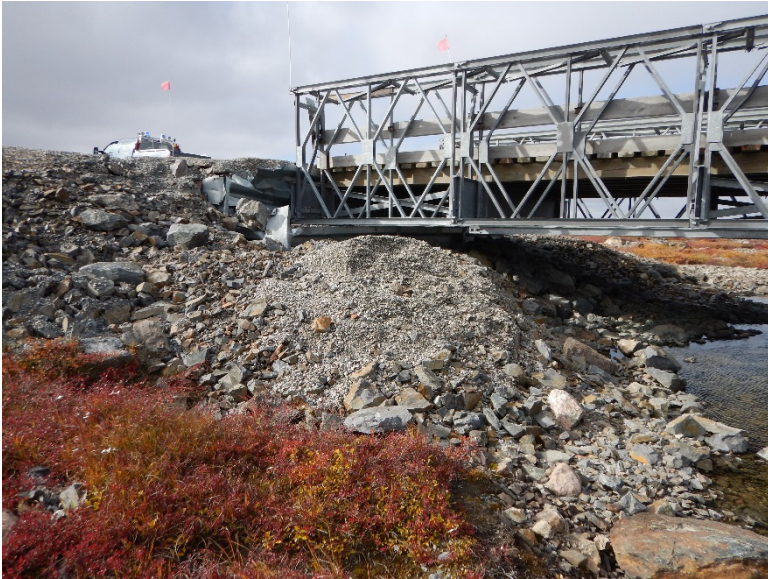

Photograph D2-15 Bridges 6 – R15 km 69+200

Date: September 10, 2016

Photo Number: 85

Description: Looking at the south abutment from downstream. Damage to the bin wall likely caused during snow removal activities. Bridge is tipping toward the west side on the abutment.



Photograph D2-16 Bridges 6 – R15 km 69+200

Date: September 10, 2016

Photo Number: 86

Description: Looking at the north abutment from downstream. Damage to the bin wall likely caused during snow removal activities. Bridge is tipping toward the west side on the abutment.



APPENDIX D2 BRIDGES PHOTOGRAPHIC LOG



Photograph D2-17 Bridges 6 – R15 km 69+200

Date: September 10, 2016

Photo Number: 84

Description: Looking at the north abutment from upstream. Damage to the bin wall likely caused during snow removal activities. Bridge is tipping toward the west side on the abutment.



Photograph D2-18 Bridges 6 – R15 km 69+200

Date: September 10, 2016

Photo Number: 83

Description: Looking at the south abutment from upstream. Damage to the bin wall likely caused during snow removal activities. Bridge is tipping toward the west side on the abutment.



APPENDIX D2 BRIDGES PHOTOGRAPHIC LOG



Photograph D2-19 Bridges 7 – R16 km 73+800

Date: September 10, 2016

Photo Number: 77

Description: Looking at the bridge from the west side.



Photograph D2-20 Bridges 7 – R16 km 73+800

Date: September 10, 2016

Photo Number: 78

Description: Looking at the bridge from the east side.



APPENDIX D2 BRIDGES PHOTOGRAPHIC LOG



Photograph D2-21 Bridges 8 – R18 km 79+500

Date: September 10, 2016

Photo Number: 73

Description: Looking at the bridge from the west side.

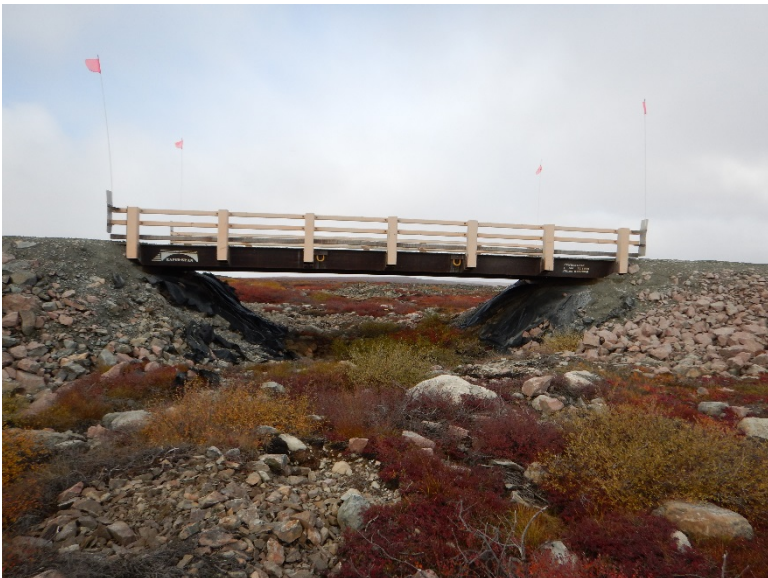

Photograph D2-22 Bridges 8 – R18 km 79+500

Date: September 10, 2016

Photo Number: 74

Description: Looking at the bridge from the east side.



APPENDIX D2 BRIDGES PHOTOGRAPHIC LOG



Photograph D2-23 Bridges 9 – R19 km 83+150

Date: September 10, 2016

Photo Number: 65

Description: Looking at the south abutment from downstream.



Photograph D2-24 Bridges 9 – R19 km 83+150

Date: September 10, 2016

Photo Number: 66

Description: Looking at the north abutment from downstream



APPENDIX D2 BRIDGES PHOTOGRAPHIC LOG



Photograph D2-25 Bridges 9 – R19 km 83+150

Date: September 10, 2016

Photo Number: 63

Description: Looking at the south abutment from upstream.



Photograph D2-26 Bridges 9 – R19 km 83+150

Date: September 10, 2016

Photo Number: 64

Description: Looking at the north abutment from upstream



APPENDIX E

Quarries Photographic Log

REFER TO UPDATED
PLAN VIEW

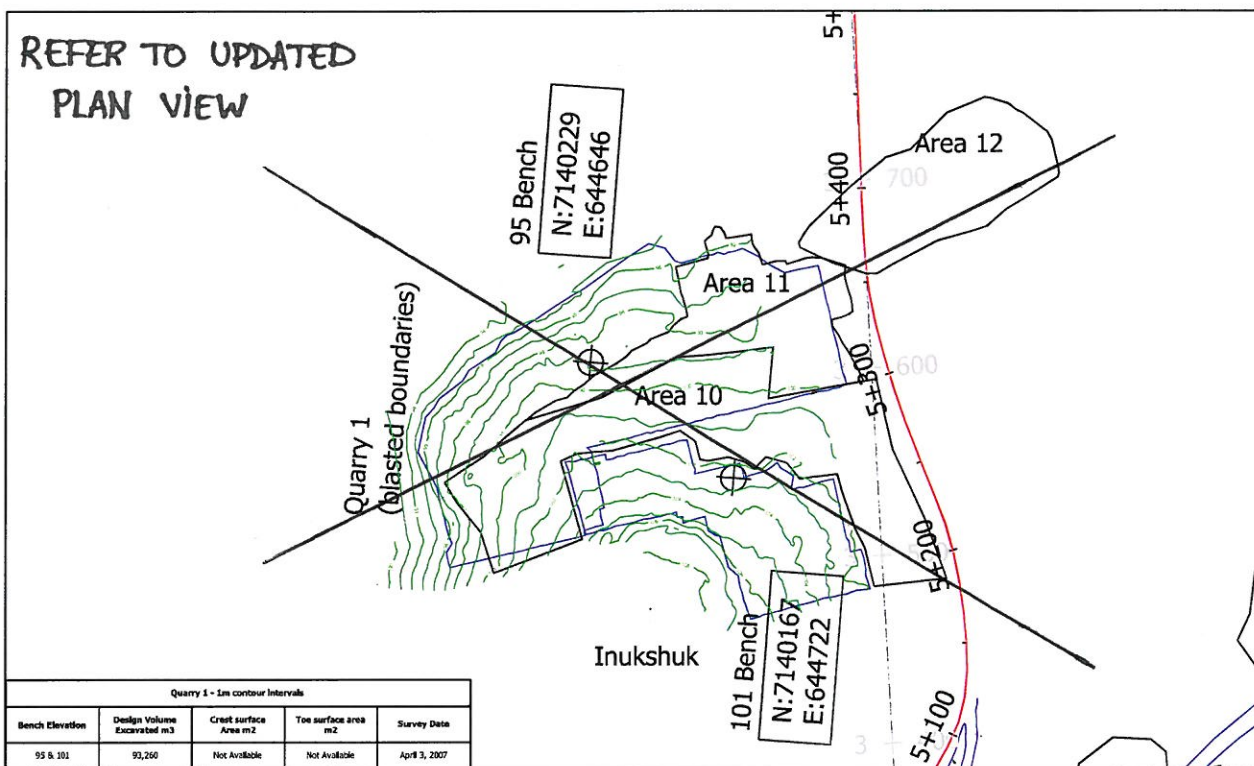

Quarry 1 - 1m contour intervals				
Bench Elevation	Design Volume Excavated m ³	Crest surface Area m ²	Toe surface area m ²	Survey Date
95 & 101	93,260	Not Available	Not Available	Apr 3, 2007

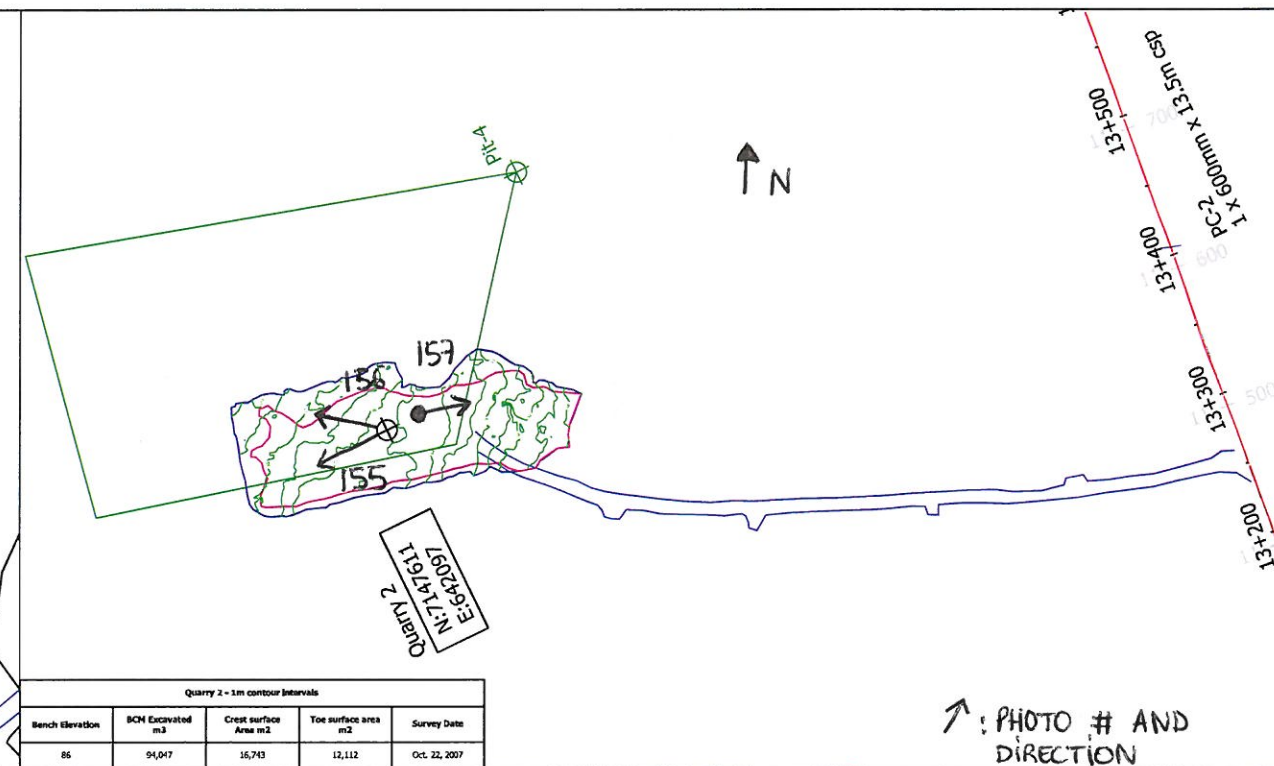

Quarry 2 - 1m contour intervals				
Bench Elevation	BCM Excavated m ³	Crest surface Area m ²	Toe surface area m ²	Survey Date
86	94,047	16,743	12,112	Oct. 22, 2007

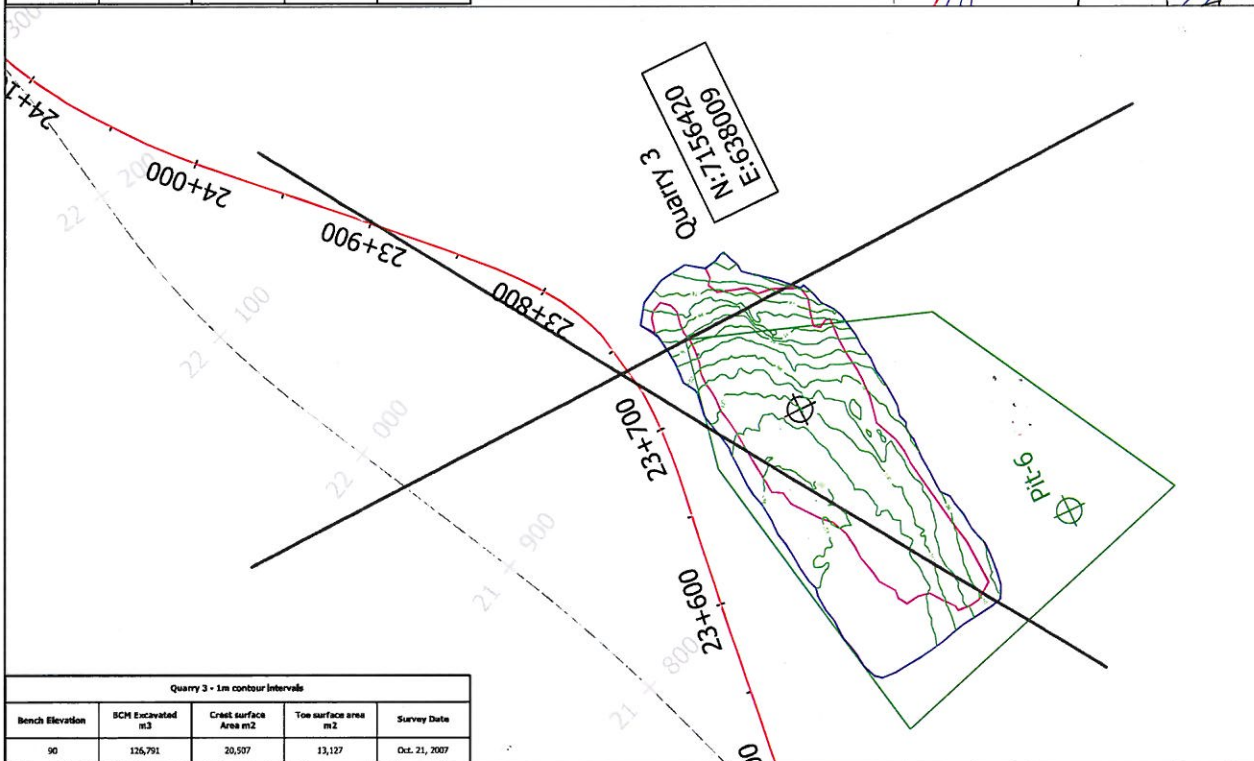

Quarry 3 - 1m contour intervals				
Bench Elevation	BCM Excavated m ³	Crest surface Area m ²	Toe surface area m ²	Survey Date
90	126,791	30,597	13,127	Oct. 21, 2007

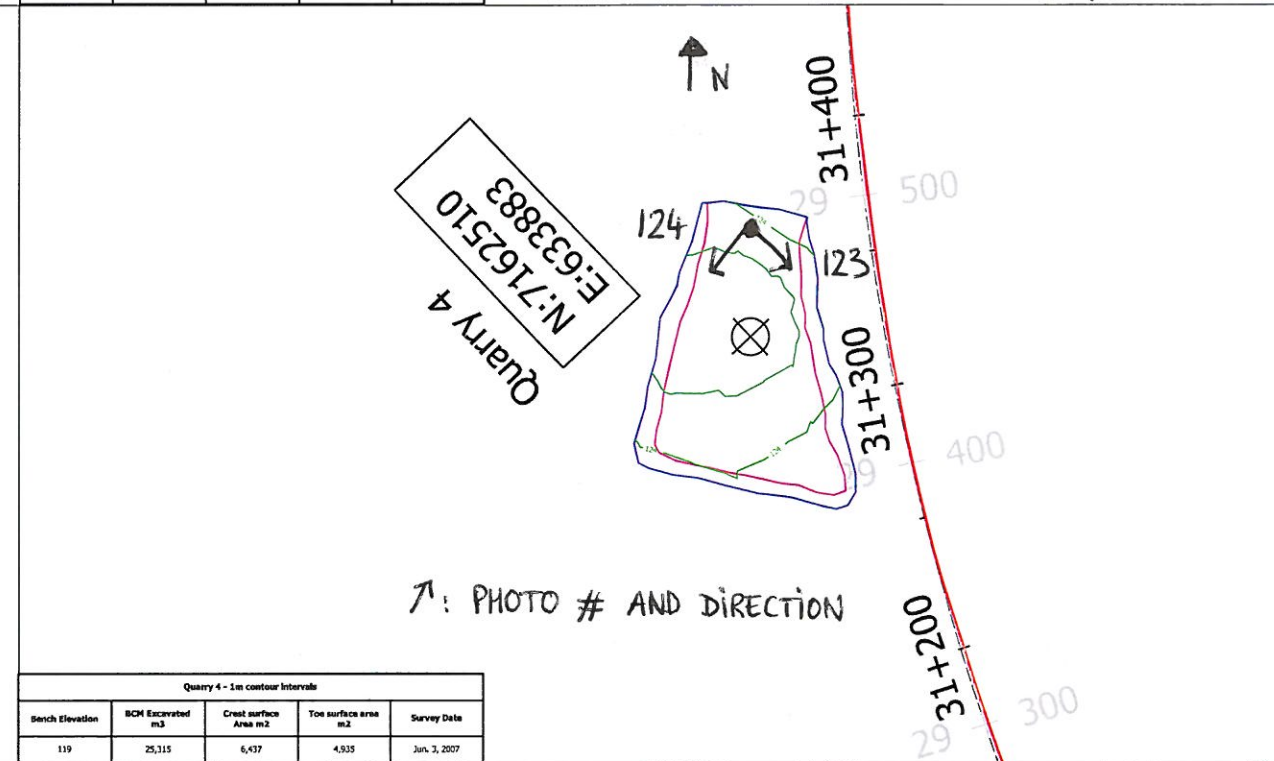

Quarry 4 - 1m contour intervals				
Bench Elevation	BCM Excavated m ³	Crest surface Area m ²	Toe surface area m ²	Survey Date
119	25,115	6,437	4,938	Jun. 2, 2007

GOLDER DATA

- LfLa-3 Existing Archeological site
- Pit-13 Proposed Quarry Site
- R02 River crossing (crossing structure and dimension)
- 120 Existing major contour (10m Topo)
- 1+000 Existing minor contour (Interpreted)
- 1+000 Proposed centerline of road

AS CONSTRUCTED DATA

- 172 Quarry original ground 2m major contour
- 120 Quarry original ground 1m minor contour
- Crest boundary of quarry bank at original ground
- Toe boundary of quarry excavation at bench grade
- 1+200 Centerline of road with 100m stations
- R02 PC-1 River crossing-culvert 600mm/1200mm dia
- R02 River Crossing-12m/30m bridges

NOTES:

Quarry Data Summarized in Table 1
100m stations are referenced to 0+000 N 7135821.224 E 64626.187

Agnico-Eagle Mines Ltd

Meadowbank Gold Project
Tehek Access Road Construction
As constructed Quarry Drawing Figure 1
Quarry 1 to Quarry 4

DATE: March 31, 2008

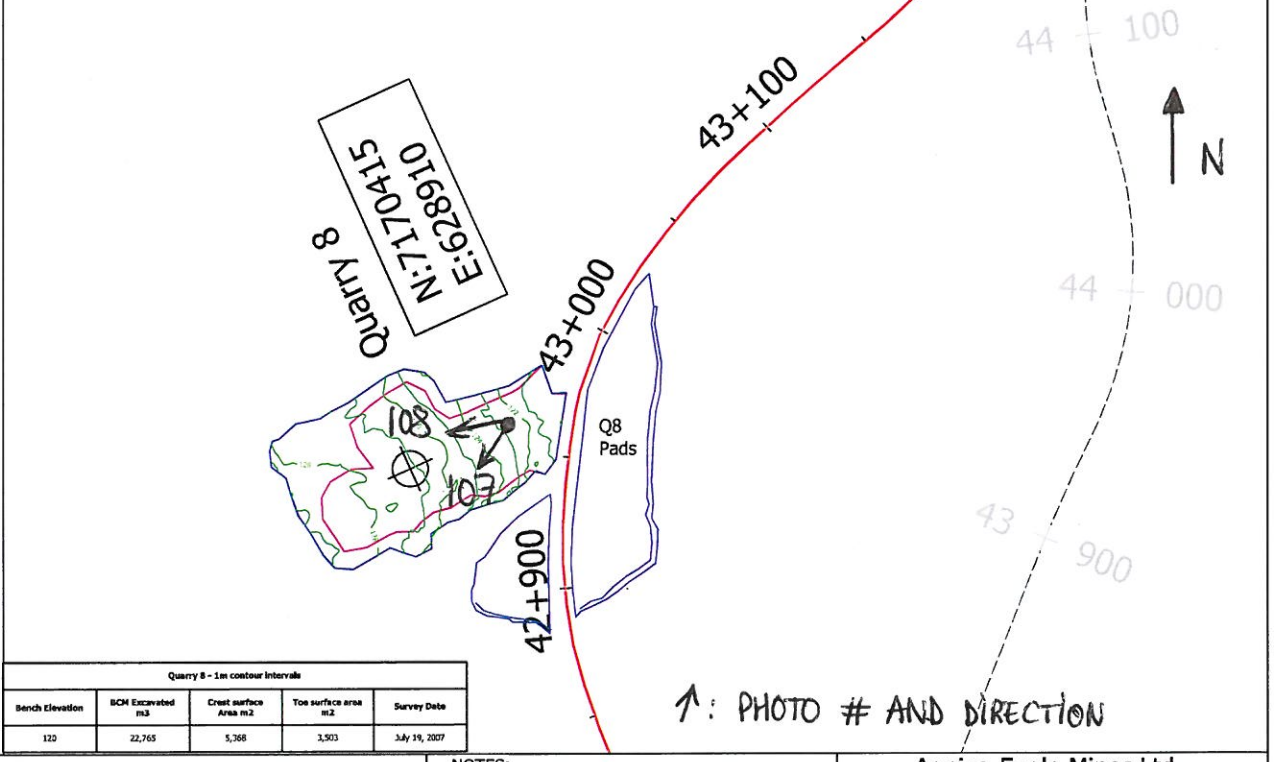
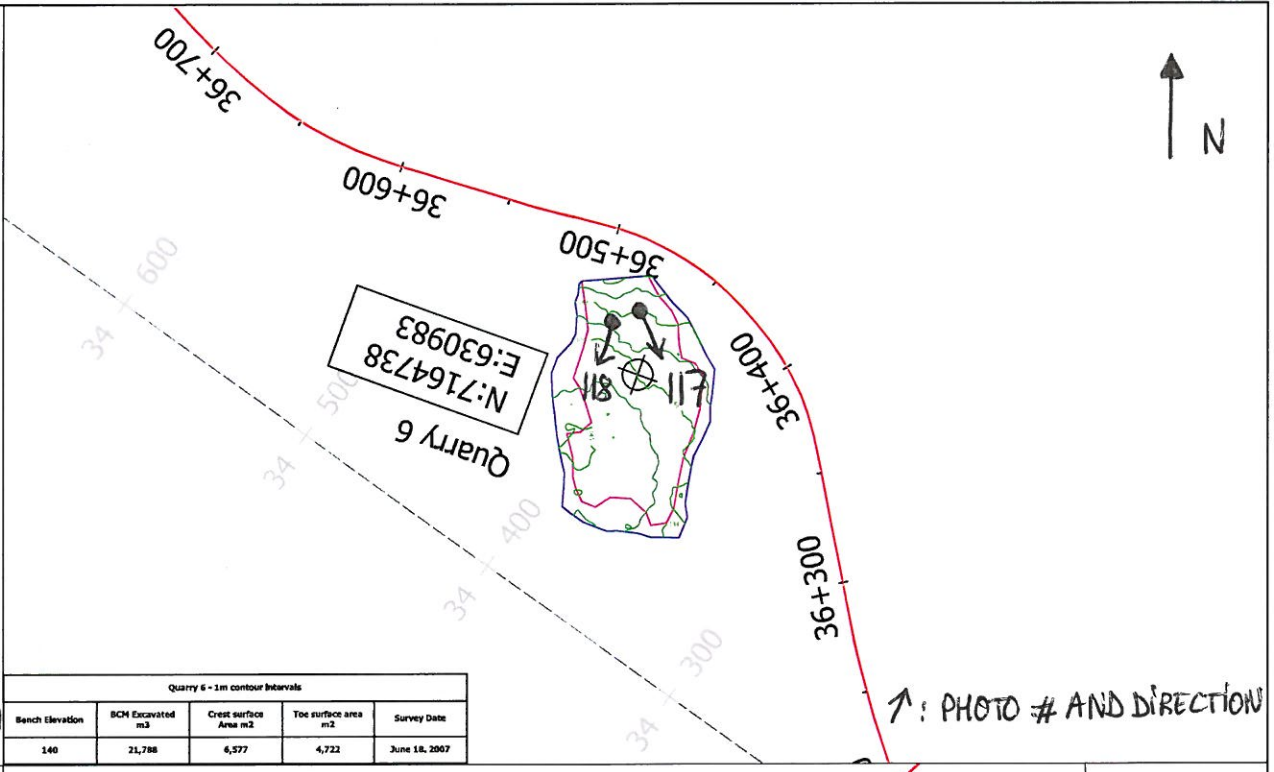
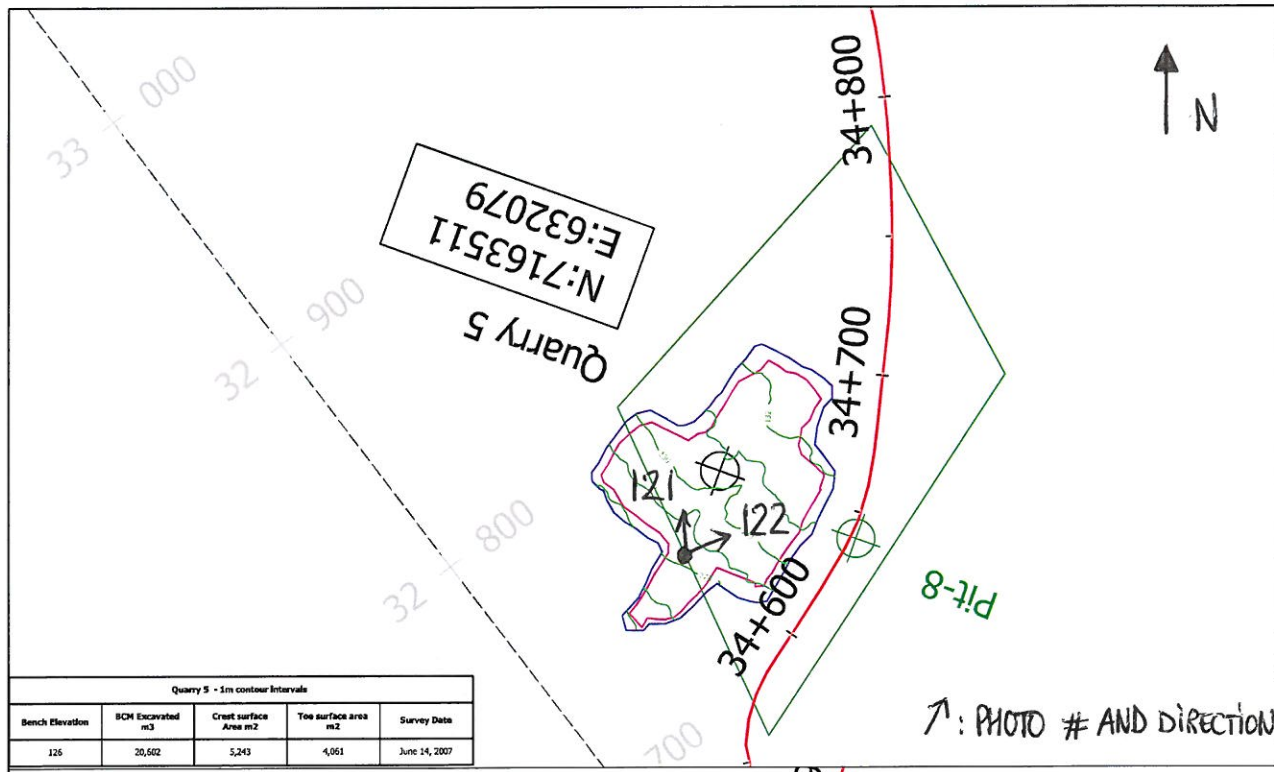

GOLDER DATA

- LfLa-3 Existing Archeological site
- Pit-13 Proposed Quarry Site
- R02 River crossing (crossing structure and dimension)
- 120 Existing major contour (10m Topo)
- 1+000 Existing minor contour (Interpreted)
- 1+000 Proposed centerline of road

AS CONSTRUCTED DATA

- 172 Quarry original ground 2m major contour
- 120 Quarry original ground 1m minor contour
- 1+000 Crest boundary of quarry limit at original ground
- 1+000 Toe boundary of quarry excavation at bench grade
- 1+200 Centerline of road with 100m stations
- R02 PC-1 River crossing-culvert 600mm/1220mm dia
- R02 River Crossing-12m30m bridge

NOTES:

Quarry Data Summarized in Table 1
100m stations are referenced to 0+000 N 7135821.224 E 646026.187

Agnico-Eagle Mines Ltd

Meadowbank Gold Project
Tehek Access Road Construction

As constructed Quarry Drawing Figure 2
Quarry 5 to Quarry 8

NUNA
MNS, PC, CQ, CB
March 31, 2008

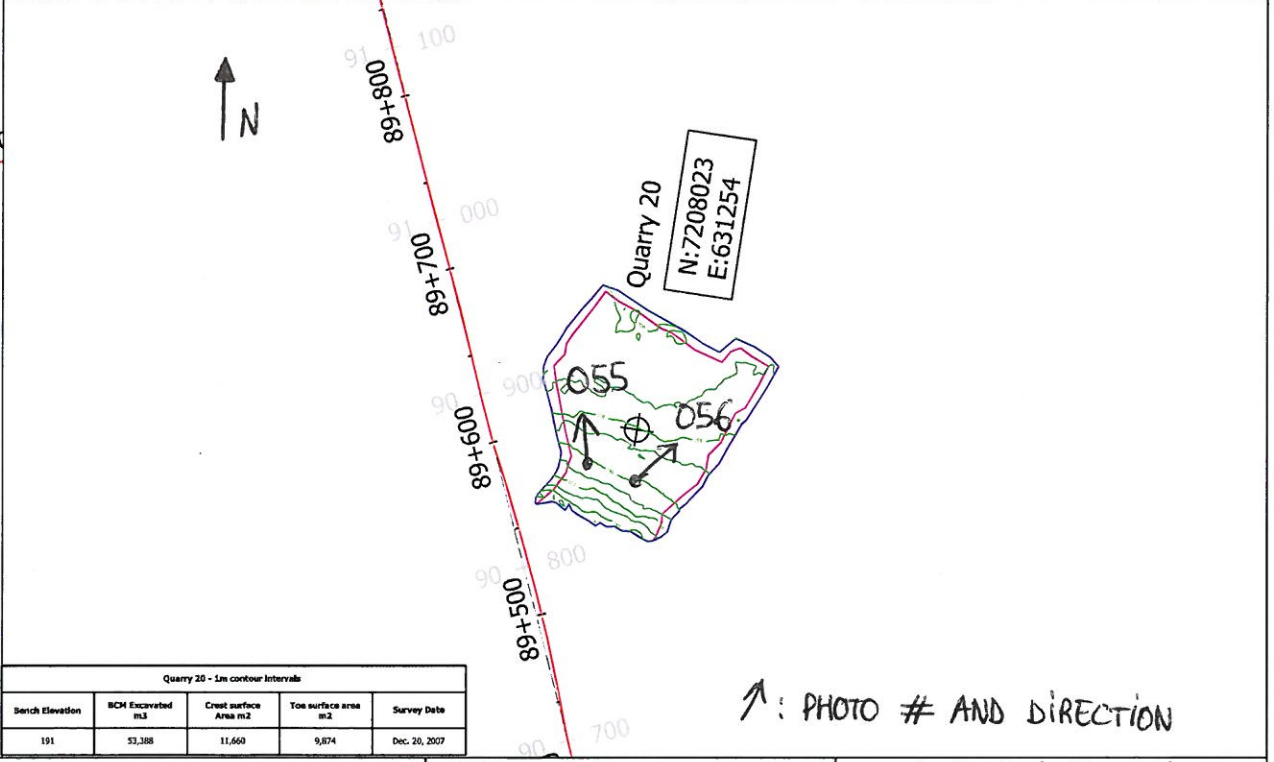
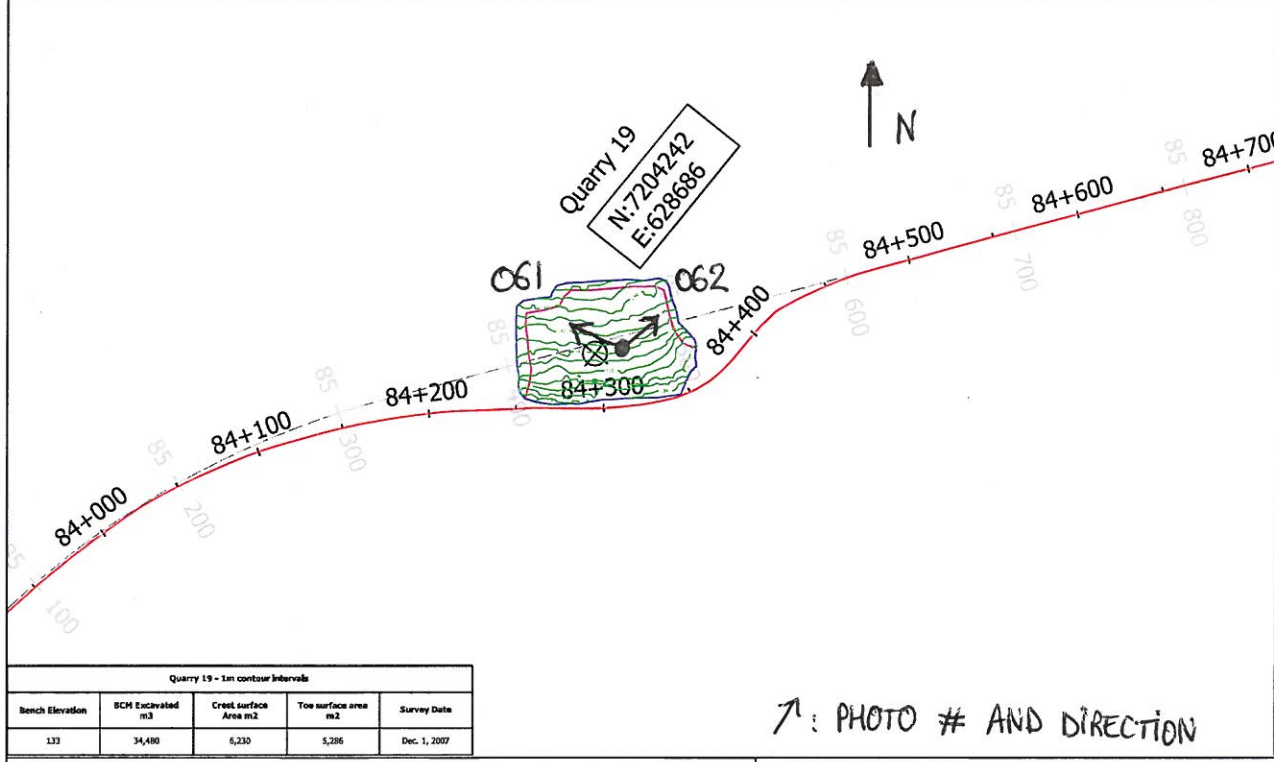
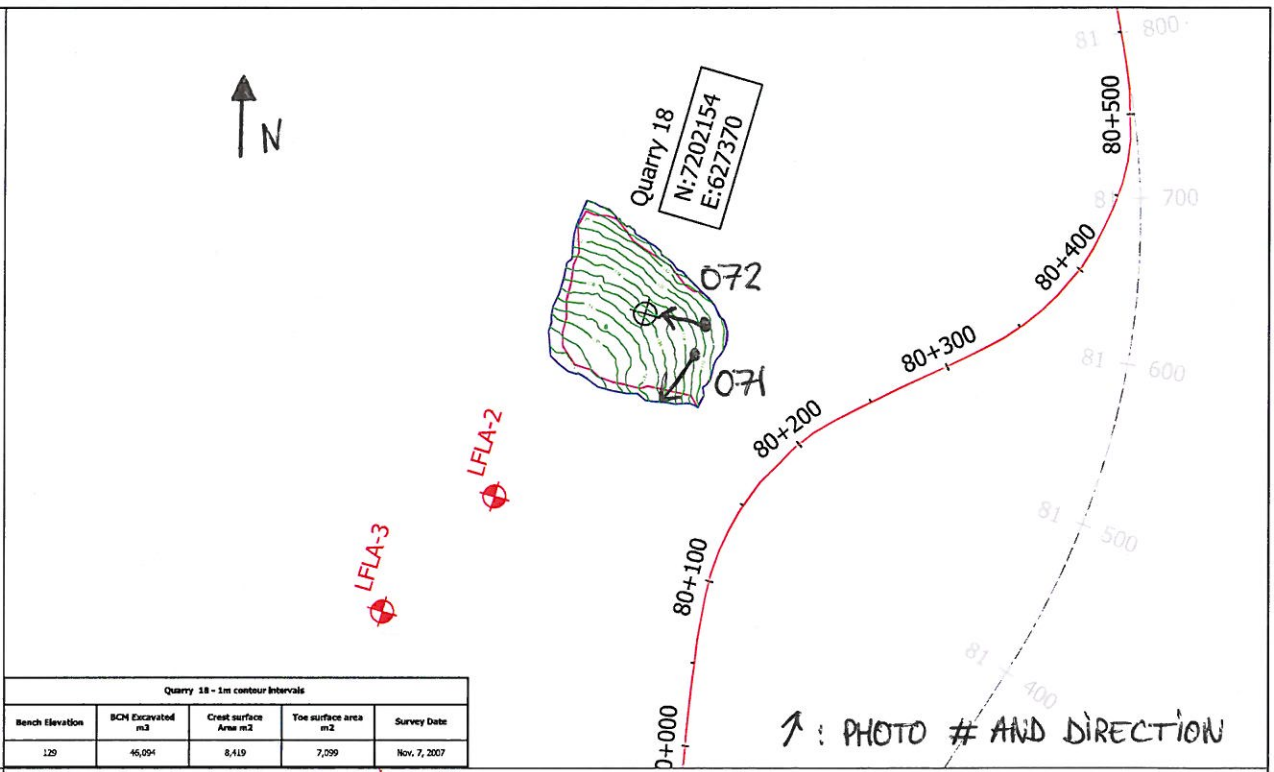
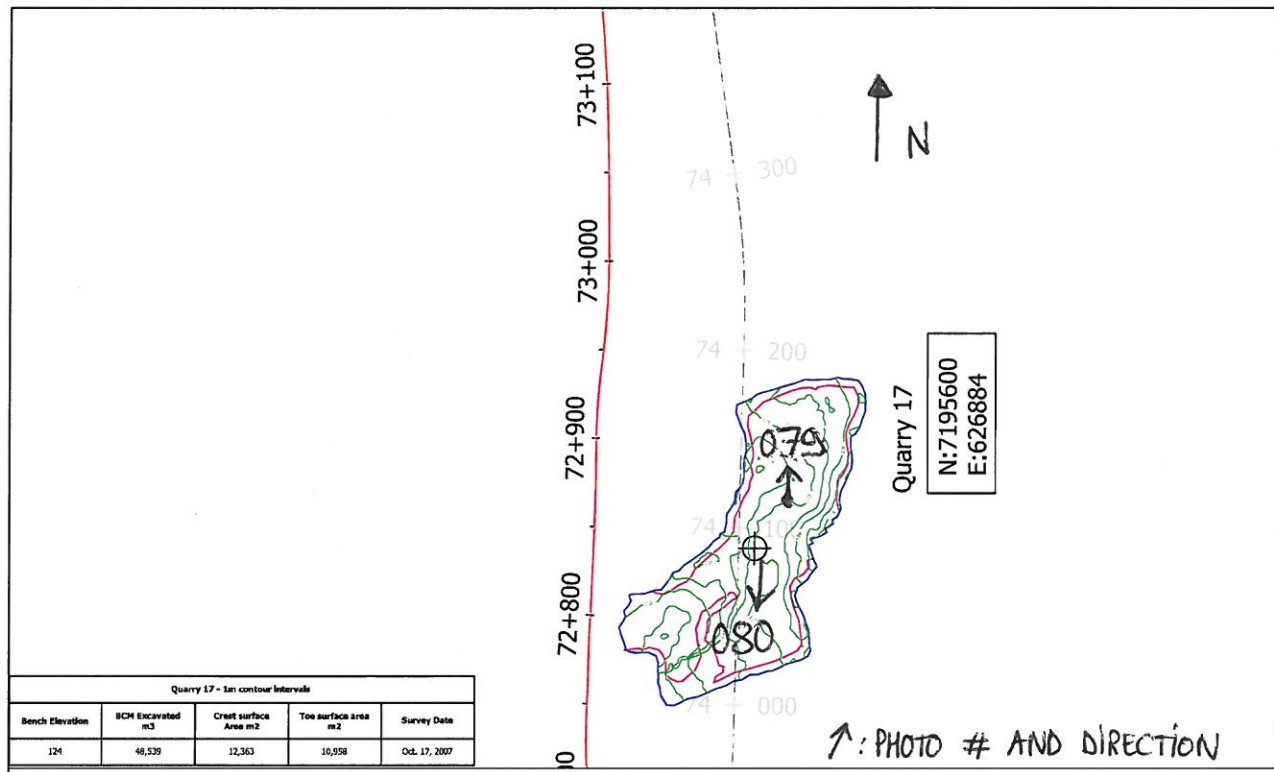

GOLDER DATA

LFLa-3 Existing Archaeological site	R02 River crossing (crossing structure and dimension)
Pit-13 Proposed Quarry Site	120 Existing major contour (10m Topo)
Existing Lake/Stream	1+000 Existing minor contour (Interpreted)
	1+000 Proposed centerline of road

AS CONSTRUCTED DATA

172 Quarry original ground 2m major contour	1+200 Centerline of road with 100m stations
Quarry original ground 1m minor contour	R20 River crossing-culvert 600mm/1200mm dia
Crest boundary of quarry limit at original ground	R02 River Crossing-12m/30m bridges
Toe boundary of quarry excavation at bench grade	

NOTES:

Quarry Data Summarized in Table 1
100m stations are referenced to 8+000 N 7135821.224 E 646036.187

Agnico-Eagle Mines Ltd

Meadowbank Gold Project
Tehek Access Road Construction

As constructed Quarry Drawing Flaure.5
Quarry 17 to Quarry 20

NTS	PH	CG/HB	March 31, 2008
-----	----	-------	----------------

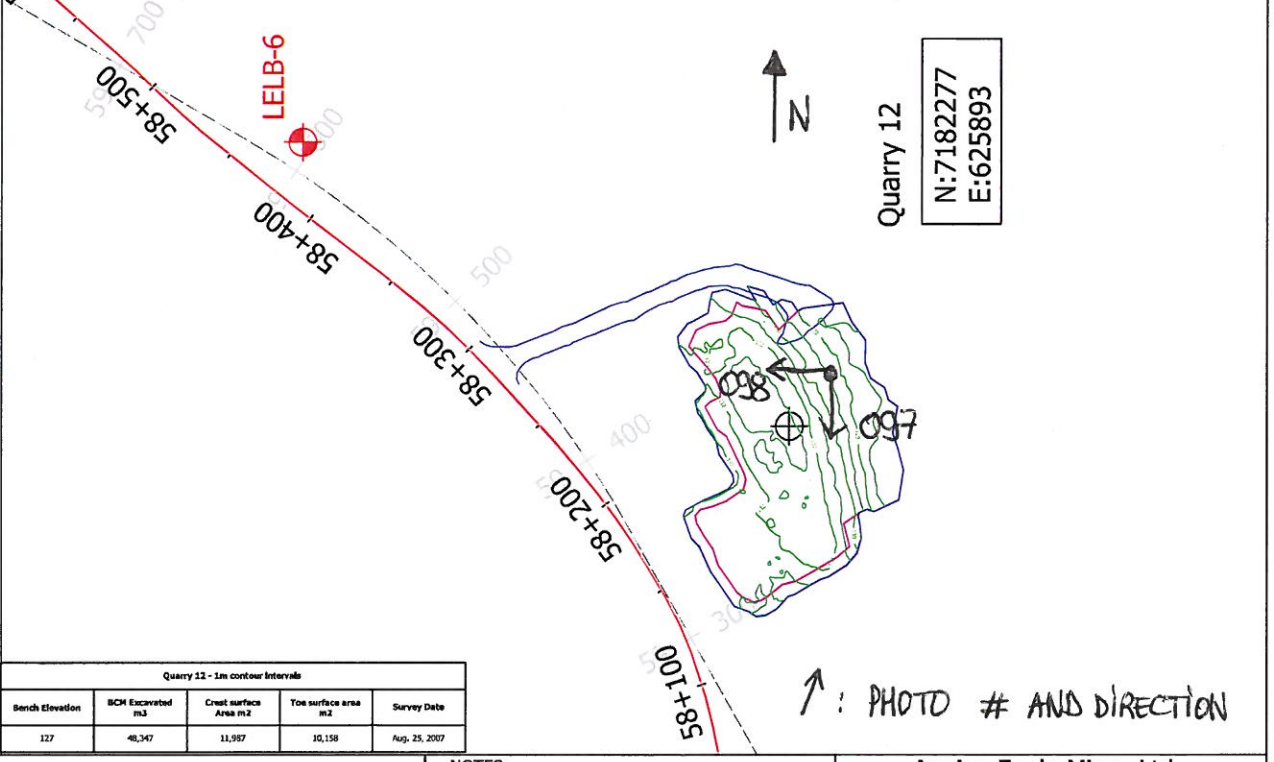
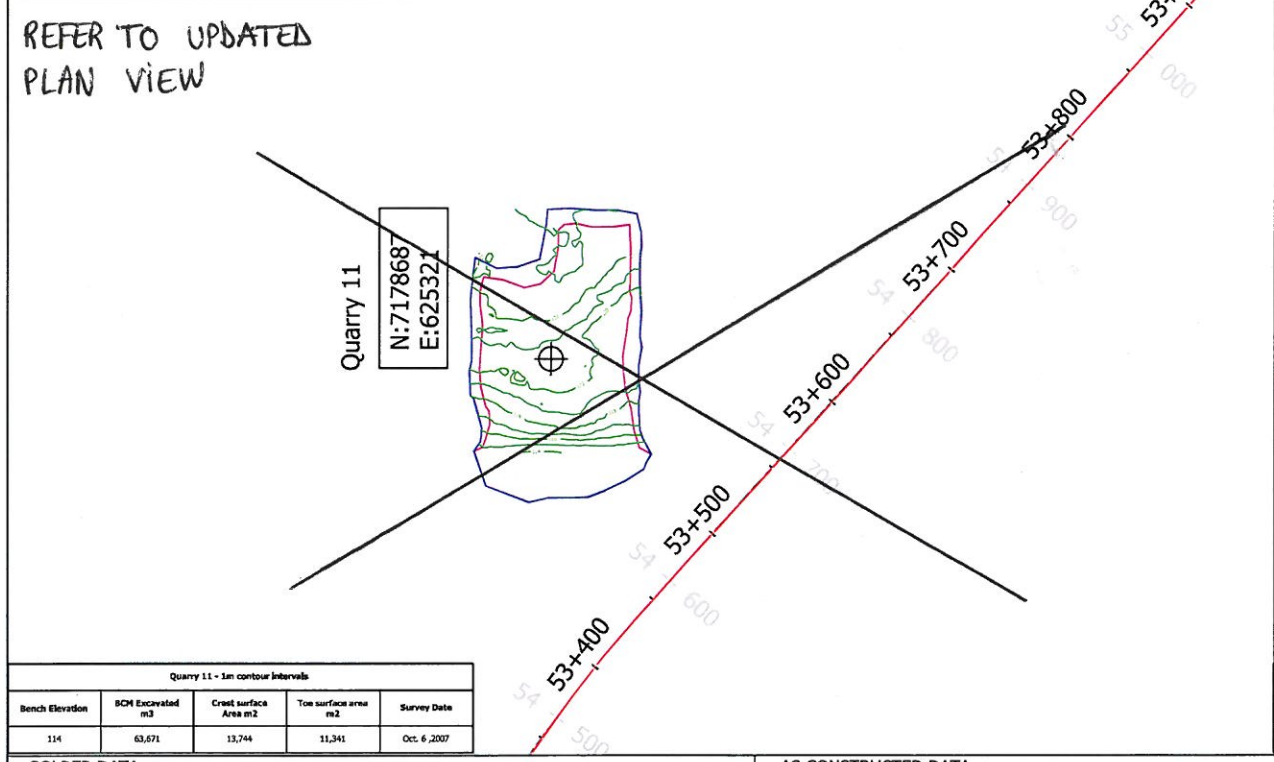
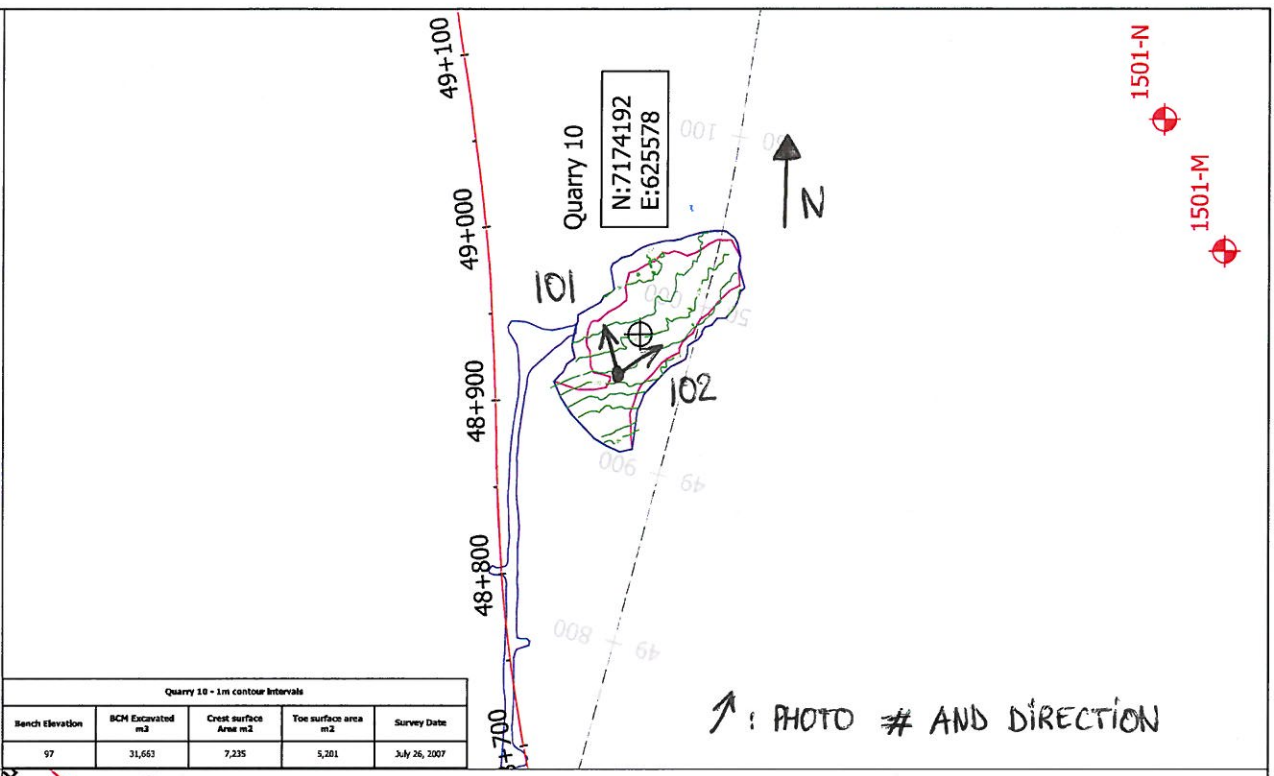
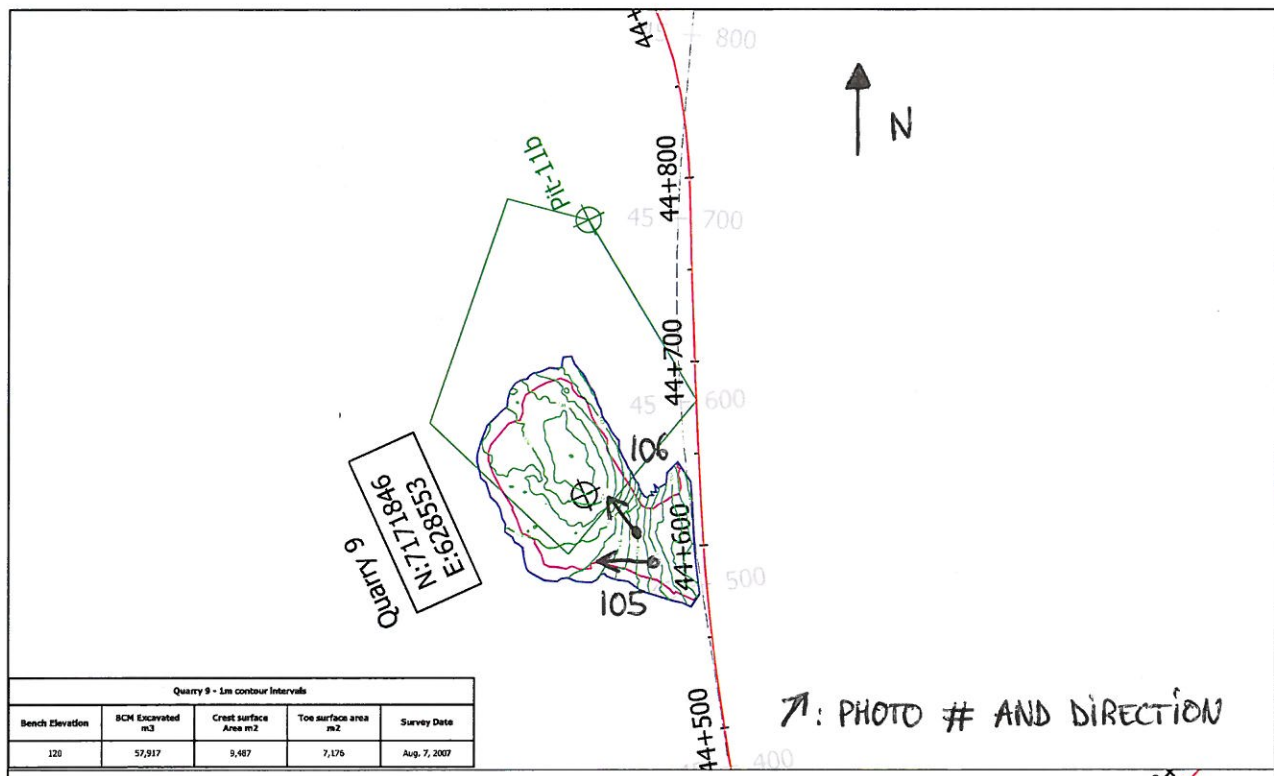

GOLDER DATA

Lfla-3	Existing Archeological site	R02	River crossing (crossing structure and dimension)
Pit-13	Proposed Quarry Site	120	Existing major contour (10m Topo)
	Existing Lake/Stream	1+000	Existing minor contour (Interpreted)
		1+000	Proposed centerline of road

AS CONSTRUCTED DATA

172	Quarry original ground 2m major contour	1+200	Centerline of road with 100m stations
1m	Quarry original ground 1m minor contour	R02	River crossing-culvert 600mm/1200mm dia
Crest	Crest boundary of quarry limit at original ground	R02	River Crossing-12m/30m bridges
Toe	Toe boundary of quarry excavation at bench grade		

NOTES:

Quarry Data Summarized in Table 1
 100m stations are referenced to 0+000 N 7125821.224 E 646026.187

Agnico-Eagle Mines Ltd

Meadowbank Gold Project
 Tehek Access Road Construction
 As constructed Quarry Drawing Floure 3
 Quarry 9 to Quarry 12

NUNA
 M. & T. NEWMAN LTD.

DATE: March 31, 2009

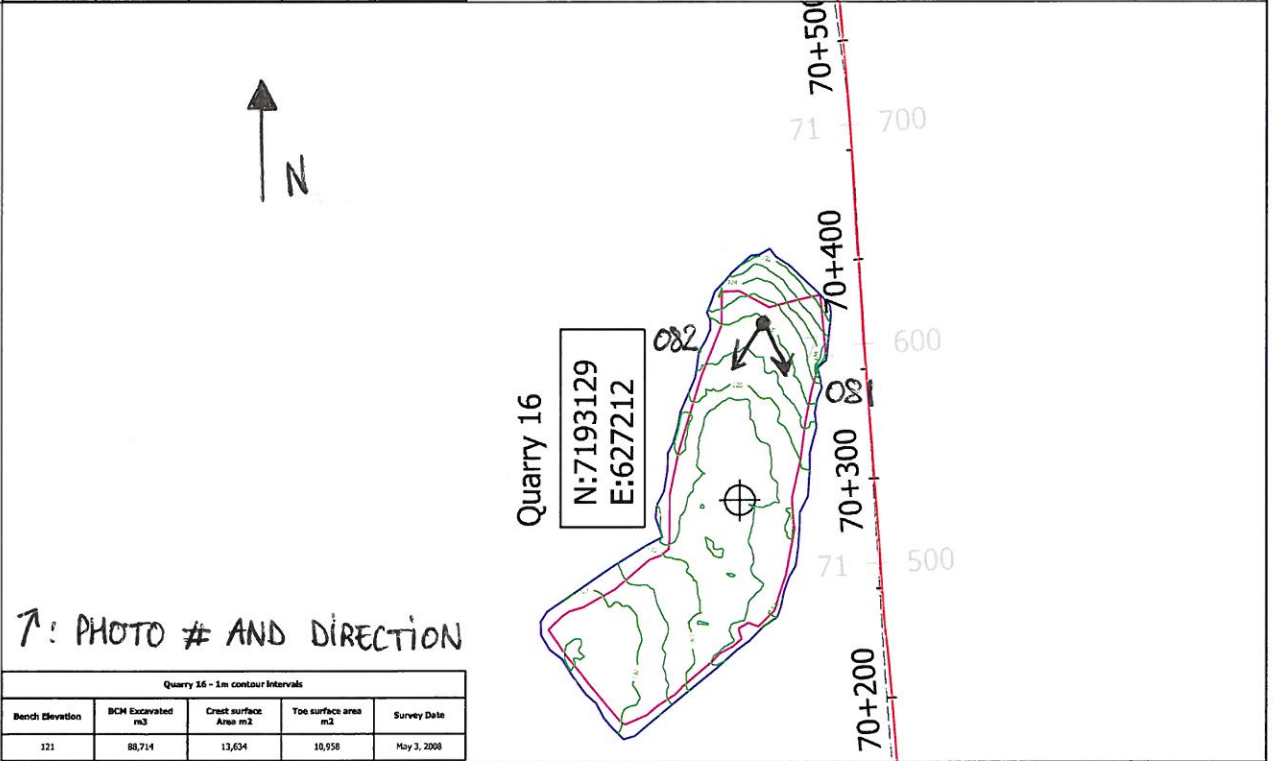
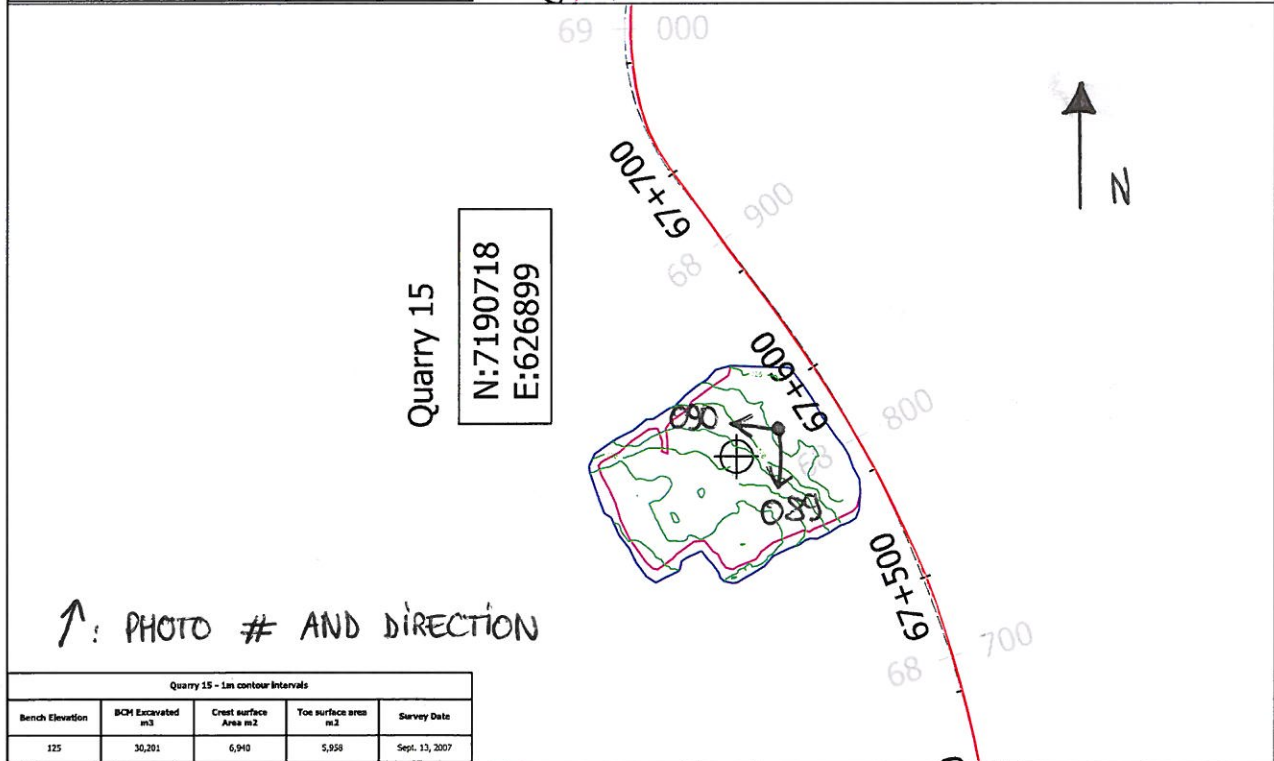
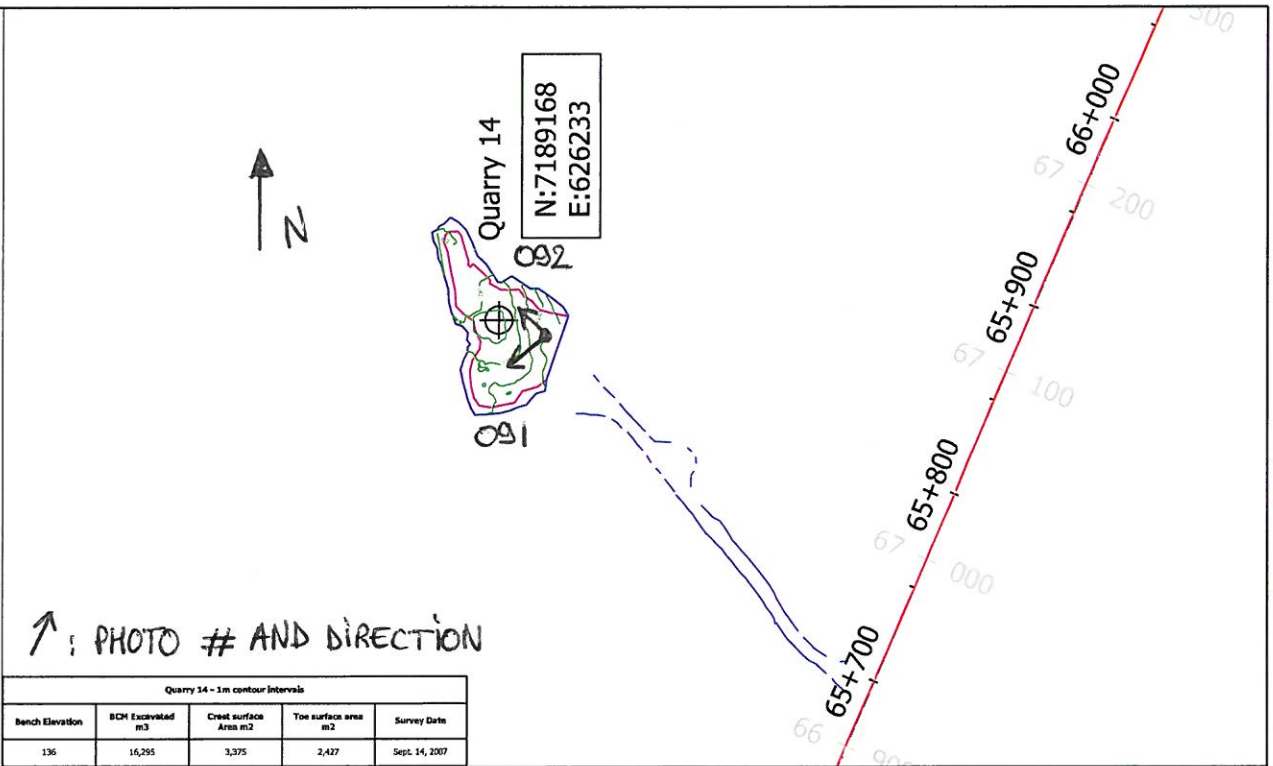
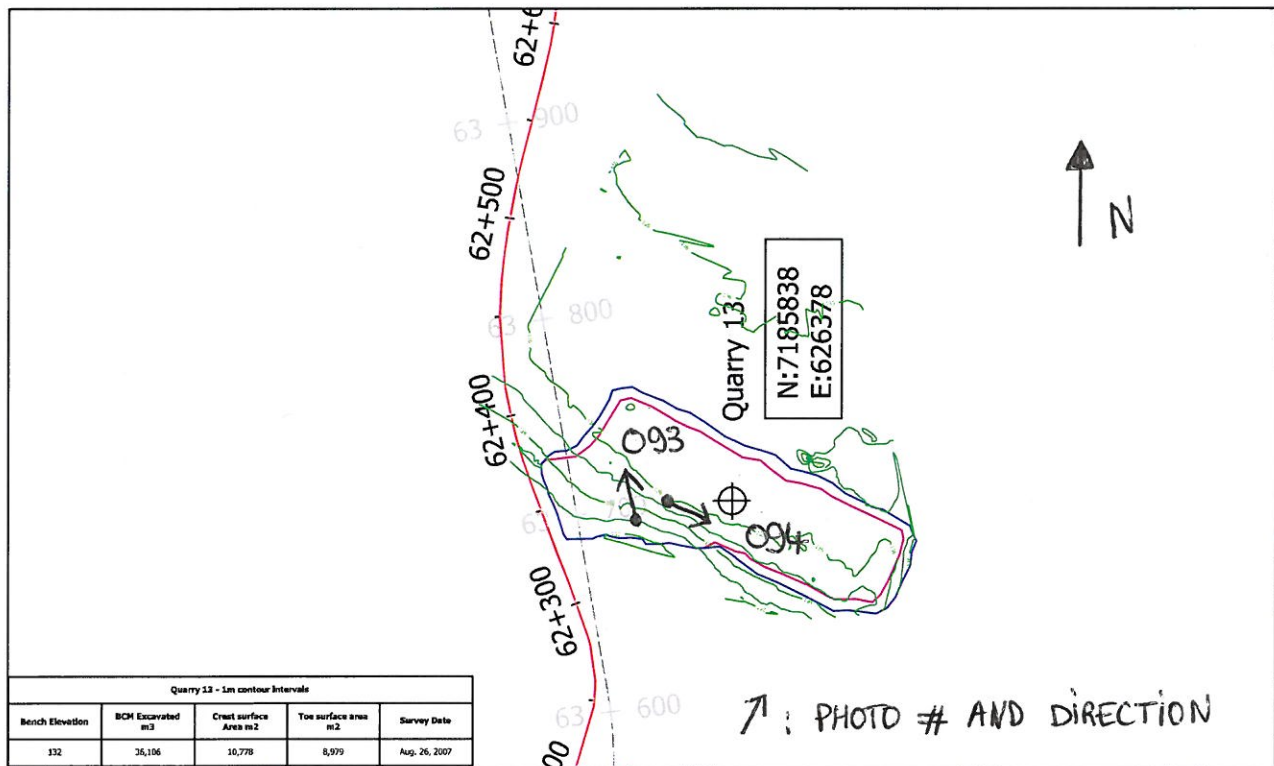

GOLDER DATA

- Existing Archeological site
- Proposed Quarry Site
- Existing Lake/Stream
- River crossing (crossing structure and dimension)
- Existing major contour (10m Topo)
- Existing minor contour (Interpreted)
- Proposed centreline of road

AS CONSTRUCTED DATA

- Quarry original ground 2m major contour
- Quarry original ground 1m minor contour
- Crest boundary of quarry bank at original ground
- Toe boundary of quarry excavation at bench grade
- Centreline of road with 100m stations
- River crossing-culvert 600m x 1200mm dia
- River Crossing-12m x 30m bridges

NOTES:

Quarry Data Summarized in Table 1
 100m stations are referenced to 0+000 N 7135821.224 E 646026.187

Agnico-Eagle Mines Ltd

Meadowbank Gold Project
 Tehék Access Road Construction

As constructed Quarry Drawing Figure 4
 Quarry 13 to Quarry 16

NUNA
 M & T NEUBERGER LTD.

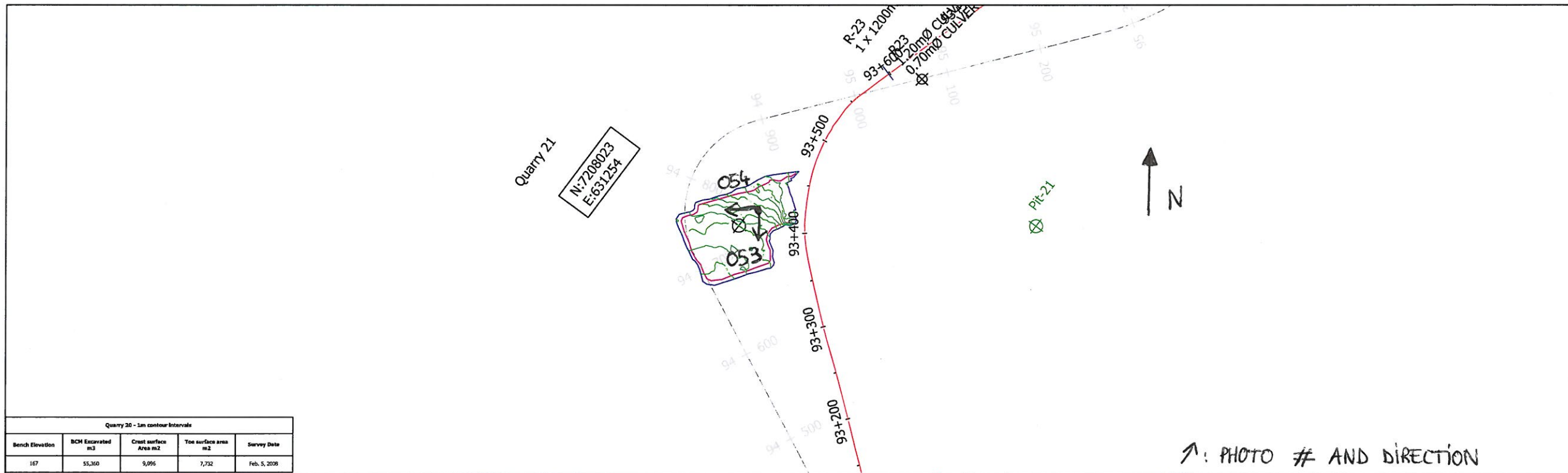

Quarry 20 - 1m contour intervals				
Bench Elevation	BCH Excavated m3	Crest surface Area m2	Toe surface area m2	Survey Date
167	55,360	9,095	7,732	Feb. 5, 2008

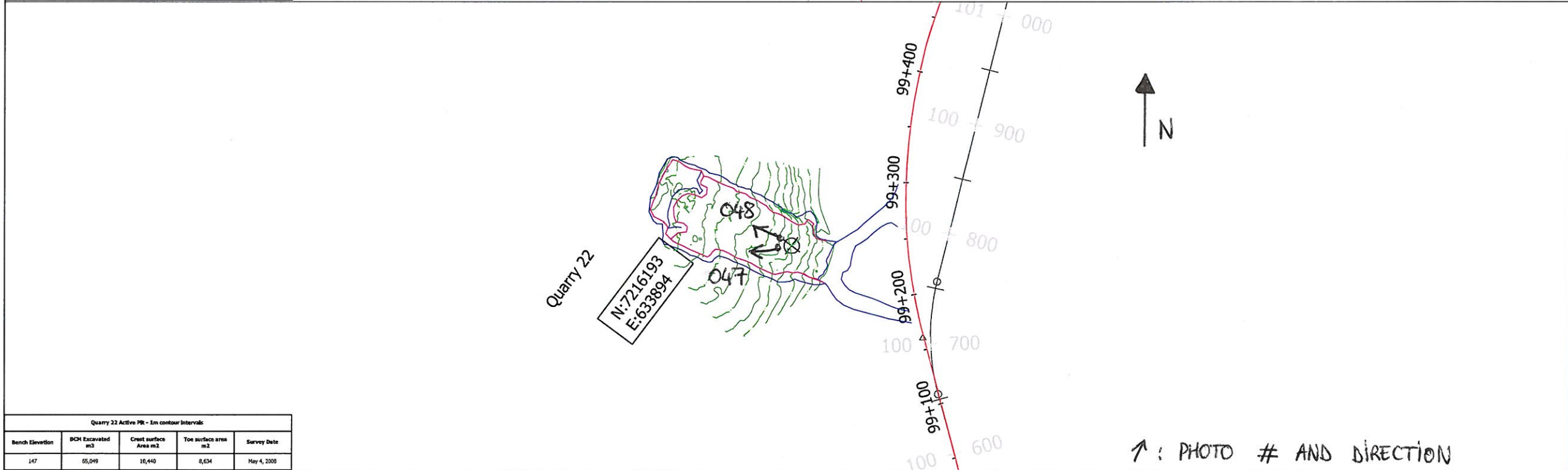

Quarry 22 Active PR - 5m contour intervals				
Bench Elevation	BCH Excavated m3	Crest surface Area m2	Toe surface area m2	Survey Date
147	55,049	16,440	8,634	May 4, 2008

GOLDER DATA

- Lfla-3 Existing Archeological site
- Pit-13 Existing Lake/Stream
- R02 River crossing (crossing structure and dimension)
- 120- Existing major contour (10m Topo)
- 1+080- Existing minor contour (Interpreted)
- 1+080- Proposed centerline of road

AS CONSTRUCTED DATA

- 172- Quarry original ground 2m major contour
- Quarry original ground 1m minor contour
- Crest boundary of quarry limit at original ground
- Toe boundary of quarry excavation at bench grade
- 1+200- Centerline of road with 100m stations
- R02 PC-1 River crossing-culvert 600mm/1200mm dia
- R02 River Crossing-12m/30m bridges

NOTES:

Quarry Data Summarized in Table 1
 100m stations are referenced to 0+000 N 713581.224 E 646026.187

Agnico-Eagle Mines Ltd

Meadowbank Gold Project
 Tehek Access Road Construction

As constructed Quarry Drawing Figure 6
 Quarry 21 to Quarry 22

NUMA
 M & T NEUBERGER LTD.

NTS RC CUP/B May 4, 2008



APPENDIX E1 QUARRIES PHOTOGRAPHIC LOG



Photograph E1-1: Quarry 1 – km 5+200

Date: September 13, 2016

Photo Number: 177

Description: View of south walls.



Photograph E1-2: Quarry 1 – km 5+200

Date: September 13, 2016

Photo Number: 176

Description: View of south and west walls.



APPENDIX E1 QUARRIES PHOTOGRAPHIC LOG



Photograph E1-3: Quarry 2 – km 13+250

Date: September 13, 2016

Photo Number: 157

Description: View of north and east walls.



Photograph E1-4: Quarry 2 – km 13+250

Date: September 13, 2016

Photo Number: 155

Description: View of north and west walls.



APPENDIX E1
QUARRIES PHOTOGRAPHIC LOG



Photograph E1-5: Quarry 2 – km 13+250

Date: September 13, 2016

Photo Number: 156

Description: View of west and south walls.



Photograph E1-6: Quarry 3 – km 23+700

Date: September 13, 2016

Photo Number: 130

Description: View of west wall. Presence of loose rock along steep wall.



APPENDIX E1 QUARRIES PHOTOGRAPHIC LOG



Photograph E1-7: Quarry 3 – km 23+700

Date: September 13, 2016

Photo Number: 129

Description: View of east wall.



Photograph E1-8: Quarry 4 – km 31+300

Date: September 13, 2016

Photo Number: 123

Description: View of the east and south walls of Quarry 4. The quarry is flooded.



APPENDIX E1 QUARRIES PHOTOGRAPHIC LOG



Photograph E1-9: Quarry 4 – km 31+300

Date: September 13, 2016

Photo Number: 124

Description: View of the west and south walls of Quarry 4. The quarry is flooded.



Photograph E1-10: Quarry 5 – km 34+650

Date: September 13, 2016

Photo Number: 122

Description: View of north and east wall. Minor accumulation of water.



APPENDIX E1 QUARRIES PHOTOGRAPHIC LOG



Photograph E1-11: Quarry 5 – km 34+650

Date: September 13, 2016

Photo Number: 121

Description: View of north and west walls. Minor accumulation of water.



Photograph E1-12: Quarry 6 – km 36+470

Date: September 13, 2016

Photo Number: 118

Description: View of south and west walls.



APPENDIX E1 QUARRIES PHOTOGRAPHIC LOG



Photograph E1-13: Quarry 6 – km 36+470

Date: September 13, 2016

Photo Number: 117

Description: View of south and east walls.



Photograph E1-14: Quarry 7 – km 39+800

Date: September 13, 2016

Photo Number: 111

Description: View of west wall. Presence of loose blocks.



APPENDIX E1 QUARRIES PHOTOGRAPHIC LOG



Photograph E1-15: Quarry 7 – km 39+800

Date: September 13, 2016

Photo Number: 112

Description: View of north wall. Loose blocks were removed.



Photograph E1-16: Quarry 8 – km 42+950

Date: September 13, 2016

Photo Number: 107

Description: View of south and west walls.



APPENDIX E1 QUARRIES PHOTOGRAPHIC LOG



Photograph E1-17: Quarry 8 – km 42+950

Date: September 13, 2016

Photo Number: 108

Description: View of north and west walls.



Photograph E1-18: Quarry 9 – km 44+600

Date: September 13, 2016

Photo Number: 105

Description: View of west and south walls. Presence of loose blocks at the base of the wall.



APPENDIX E1 QUARRIES PHOTOGRAPHIC LOG



Photograph E1-19: Quarry 9 – km 44+600

Date: September 13, 2016

Photo Number: 106

Description: View of north and east walls. View of a pile of loose material.



Photograph E1-20: Quarry 10 – km 48+900

Date: September 13, 2016

Photo Number: 101

Description: View of the west wall. Presence of unstable block.



APPENDIX E1 QUARRIES PHOTOGRAPHIC LOG



Photograph E1-21: Quarry 10 – km 48+900

Date: September 13, 2016

Photo Number: 102

Description: Overview of the quarry looking north at the east, west and north walls.



Photograph E1-22: Quarry 11 – km 53+500

Date: September 13, 2016

Photo Number: 099

Description: Overview of Quarry 11 looking at the west and north walls.



APPENDIX E1 QUARRIES PHOTOGRAPHIC LOG



Photograph E1-23: Quarry 11 – km 53+500

Date: September 13, 2016

Photo Number: 100

Description: Overview of Quarry 11 looking at the north and east walls.



Photograph E1-24: Quarry 12 – km 58+300

Date: September 13, 2016

Photo Number: 097

Description: View of the south and east walls.



APPENDIX E1 QUARRIES PHOTOGRAPHIC LOG



Photograph E1-25: Quarry 12 – km 58+300

Date: September 13, 2016

Photo Number: 098

Description: View of the west wall.



Photograph E1-26: Quarry 13 – km 62+350

Date: September 13, 2016

Photo Number: 093

Description: View of the west and north walls. Accumulation of water inside the quarry.



APPENDIX E1 QUARRIES PHOTOGRAPHIC LOG



Photograph E1-27: Quarry 13 – km 62+350

Date: September 13, 2016

Photo Number: 094

Description: Looking at the south and east walls. Accumulation of water inside the quarry.

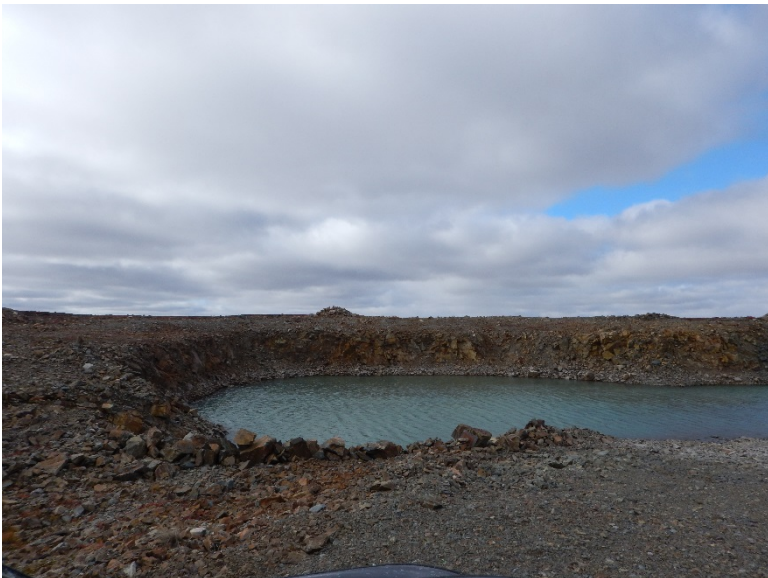

Photograph E1-28: Quarry 14 – km 65+700

Date: September 13, 2016

Photo Number: 091

Description: View of west and south walls. Quarry flooded.



APPENDIX E1 QUARRIES PHOTOGRAPHIC LOG



Photograph E1-29: Quarry 14 – km 65+700

Date: September 13, 2016

Photo Number: 092

Description: View of north and west walls. Quarry flooded.



Photograph E1-30: Quarry 15 – km 67+600

Date: September 13, 2016

Photo Number: 089

Description: View of the south and west walls.



APPENDIX E1 QUARRIES PHOTOGRAPHIC LOG

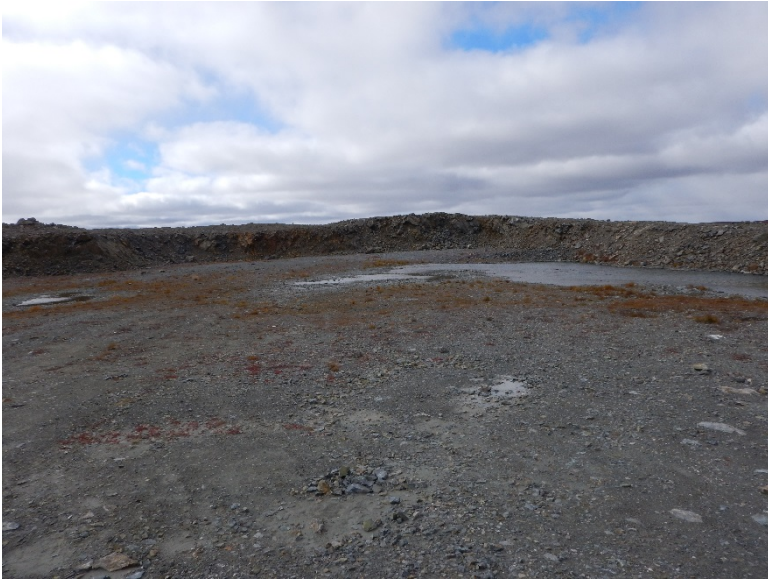

Photograph E1-31: Quarry 15 – km 67+600

Date: September 13, 2016

Photo Number: 090

Description: View of the north and west walls. Accumulation of water inside the quarry.



Photograph E1-32: Quarry 16 – km 70+400

Date: September 13, 2016

Photo Number: 082

Description: View of the south and west walls. Presence of loose rocks on steep wall.



APPENDIX E1 QUARRIES PHOTOGRAPHIC LOG



Photograph E1-33: Quarry 16 – km 70+400

Date: September 13, 2016

Photo Number: 081

Description: View of the east and south walls. Presence of loose rocks on steep wall.



Photograph E1-34: Quarry 17 – km 72+800

Date: September 13, 2016

Photo Number: 080

Description: Looking at the south and east walls.



APPENDIX E1
QUARRIES PHOTOGRAPHIC LOG



Photograph E1-35: Quarry 17 – km 72+800

Date: September 13, 2016

Photo Number: 079

Description: Looking at the north wall.



Photograph E1-36: Quarry 18 – km 80+200

Date: September 13, 2016

Photo Number: 071

Description: View of the south wall.



APPENDIX E1 QUARRIES PHOTOGRAPHIC LOG



Photograph E1-37: Quarry 18 – km 80+200

Date: September 13, 2016

Photo Number: 072

Description: Looking at the north and east walls.



Photograph E1-38: Quarry 19 – km 84+300

Date: September 13, 2016

Photo Number: 061

Description: Looking at the north and west walls.



APPENDIX E1 QUARRIES PHOTOGRAPHIC LOG



Photograph E1-39: Quarry 19 – km 84+300

Date: September 13, 2016

Photo Number: 062

Description: Looking at the north and east walls.



Photograph E1-40: Quarry 20 – km 89+550

Date: September 13, 2016

Photo Number: 055

Description: Looking at the north and west walls.



APPENDIX E1 QUARRIES PHOTOGRAPHIC LOG



Photograph E1-41: Quarry 20 – km 89+550

Date: September 13, 2016

Photo Number: 056

Description: Looking at the north and east wall.



Photograph E1-42: Quarry 21 – km 93+400

Date: September 13, 2016

Photo Number: 053

Description: Looking at the south and east walls.



APPENDIX E1 QUARRIES PHOTOGRAPHIC LOG



Photograph E1-43: Quarry 21 – km 93+400

Date: September 13, 2016

Photo Number: 054

Description: Looking at the north and the west walls.



Photograph E1-44: Quarry 22 – km 99+200

Date: September 13, 2016

Photo Number: 047

Description: View of the north and west walls.



APPENDIX E1 QUARRIES PHOTOGRAPHIC LOG



Photograph E1-45: Quarry 22 – km 99+200

Date: September 13, 2016

Photo Number: 048

Description: Looking at the north and east walls.



Photograph E1-46: Quarry 23 (Airstrip Quarry)

Date: September 13, 2016

Photo Number: 329

Description: Looking at the north wall.



APPENDIX E1 QUARRIES PHOTOGRAPHIC LOG



Photograph E1-47: Quarry 23 (Airstrip Quarry)

Date: September 13, 2016

Photo Number: 328

Description: Looking at the south wall.



Photograph E1-48: Quarry 23 (Airstrip Quarry)

Date: September 13, 2016

Photo Number: 330

Description: Looking at the north and west walls. Presence of loose rocks along steep wall.



APPENDIX E1 QUARRIES PHOTOGRAPHIC LOG



Photograph E1-49: Quarry 23 (Airstrip Quarry)

Date: September 13, 2016

Photo Number: 331

Description: Looking at the north and east walls.



Photograph E1-50: Quarry 23 (Airstrip Quarry)

Date: September 13, 2016

Photo Number: 332

Description: Looking at the south and east walls.

n:\actif\2016\3 proj\1662181 aem geotech insp 2016 meadowbank\5 preparation of deliverables\doc 1549 2016 geotechnical inspection\rev 0\3 appendices\appendix e - quarries\e - quarries photographic log 2016.docx



APPENDIX F

Bulk Fuel Storage Facilities



APPENDIX F1

Baker Lake Tank Farm Photographic Log

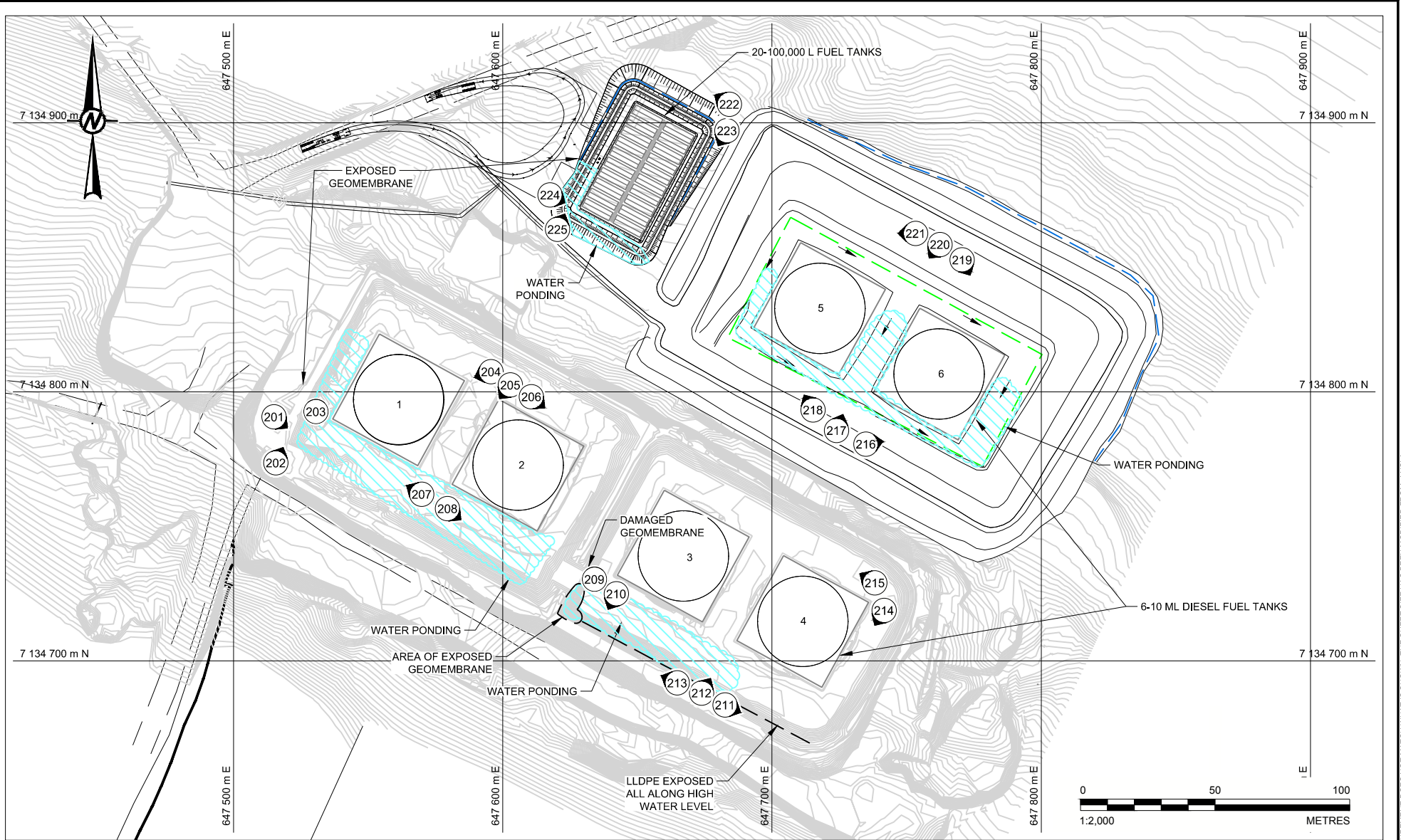

LEGEND



IDENTIFICATION AND DIRECTION OF PHOTOGRAPHY TOOK DURING THE ANNUAL INSPECTION OF 2015

NOTE

GRID REFERENCE: NAD 83, UTM ZONE 14.

REFERENCE

BASE PLAN PROVIDED BY AEM LTD. IN "PORTAGE_GOOSE_VAULT_END2018_LOM2013_V4D-WITH LABEL.dwg, RECEIVED OCTOBER 7, 2013

CLIENT



AGNICO EAGLE

CONSULTANT



YYYY-MM-DD 2017-02-06

PREPARED F. L. Bolduc

DESIGN S. Betnesky

REVIEW F. L. Bolduc

APPROVED Y. Boulianne

PROJECT

2016 ANNUAL GEOTECHNICAL INSPECTION
MEADOWBANK GOLD MINE, NUNAVUT

TITLE

TANK FARM BAKER LAKE

PROJECT No.
1662181

PHASE
4000

Rev.
0

FIGURE
F1

25 mm IF THIS MEASUREMENT DOES NOT MATCH WHAT IS SHOWN, THE SHEET SIZE HAS BEEN MODIFIED FROM: ANSI A



APPENDIX F1
BAKER LAKE TANK FARM PHOTOGRAPHIC LOG



Photograph F1-1 Baker Lake Tank Farm

Date: September 11, 2016

Photo Number: 201

Description: From the south side of Tank 1, looking southeast at Tanks 1, 2, 3, and 4. Presence of water ponding.



Photograph F1-2 Baker Lake Tank Farm

Date: September 11, 2016

Photo Number: 202

Description: Looking at the southwestern corner of Tank 1. Presence of water ponding.



APPENDIX F1
BAKER LAKE TANK FARM PHOTOGRAPHIC LOG



Photograph F1-3 Baker Lake Tank Farm

Date: September 11, 2016

Photo Number: 203

Description: Exposed area of geomembrane on the northwest side of Tank 1. Textile in place.



Photograph F1-4 Baker Lake Tank Farm

Date: September 11, 2016

Photo Number: 207

Description: Looking northwest toward the south side of Tank 1. Presence of water ponding.



APPENDIX F1
BAKER LAKE TANK FARM PHOTOGRAPHIC LOG



Photograph F1-5 Baker Lake Tank Farm

Date: September 11, 2016

Photo Number: 208

Description: Looking northeast toward the south side of Tanks 2 and 3. Presence of water ponding.



Photograph F1-6 Baker Lake Tank Farm

Date: September 11, 2016

Photo Number: 209

Description: The geomembrane between the south side of tank 2 and 3 is damaged.



APPENDIX F1 BAKER LAKE TANK FARM PHOTOGRAPHIC LOG



Photograph F1-7 Baker Lake Tank Farm

Date: September 11, 2016

Photo Number: 210

Description: From the southwestern corner of Tank 3 looking southwest. Presence of water ponding. View of exposed LLDPE.



Photograph F1-8 Baker Lake Tank Farm

Date: September 11, 2016

Photo Number: 213

Description: From the southeastern corner of Tank 3, looking northwest at the south side of Tank 3, 2 and 1. Presence of water ponding. View of exposed LLDPE.



APPENDIX F1
BAKER LAKE TANK FARM PHOTOGRAPHIC LOG

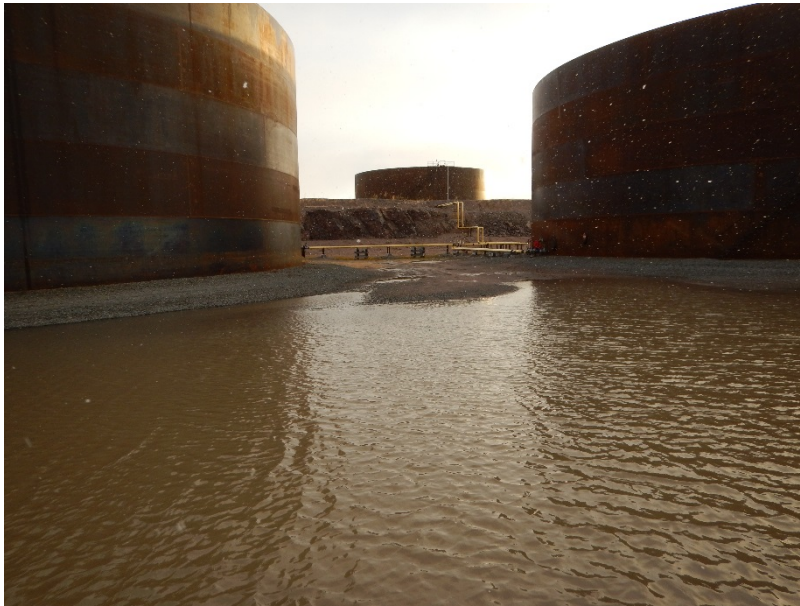

Photograph F1-9 Baker Lake Tank Farm

Date: September 11, 2016

Photo Number: 212

Description: From the south portion of the site looking north at the south side of Tank 3, 4 and 5. Presence of water ponding.



Photograph F1-10 Baker Lake Tank Farm

Date: September 11, 2016

Photo Number: 211

Description: From the south portion of the site looking southeast. Presence of water ponding. Presence of exposed LLDPE.



APPENDIX F1 BAKER LAKE TANK FARM PHOTOGRAPHIC LOG



Photograph F1-11 Baker Lake Tank Farm

Date: September 11, 2016

Photo Number: 214

Description: From the northeastern corner of Tank 4 looking southwest toward Tank 4.



Photograph F1-12 Baker Lake Tank Farm

Date: September 11, 2016

Photo Number: 215

Description: From the northern side of Tank 4, looking northwest toward Tanks 4, 3, 2, and 1.



APPENDIX F1 BAKER LAKE TANK FARM PHOTOGRAPHIC LOG



Photograph F1-13 Baker Lake Tank Farm

Date: September 11, 2016

Photo Number: 204

Description: From the northern corner of Tank 2 looking west towards the northeastern side of Tank 1.



Photograph F1-14 Baker Lake Tank Farm

Date: September 11, 2016

Photo Number: 205

Description: From the northern corner of Tank 2 looking southwest between Tanks 1 and 2.



APPENDIX F1 BAKER LAKE TANK FARM PHOTOGRAPHIC LOG



Photograph F1-15 Baker Lake Tank Farm

Date: September 11, 2016

Photo Number: 206

Description: From the northern corner of Tank 2 looking southeast towards the northeastern side of Tank 1.



Photograph F1-16 Baker Lake Tank Farm

Date: September 11, 2016

Photo Number: 218

Description: Looking northwest at the southern and western sides of Tank 5. Presence of water ponding.



APPENDIX F1
BAKER LAKE TANK FARM PHOTOGRAPHIC LOG



Photograph F1-17 Baker Lake Tank Farm

Date: September 11, 2016

Photo Number: 217

Description: Looking north between Tanks 5 and 6. Presence of water ponding.



Photograph F1-18 Baker Lake Tank Farm

Date: September 11, 2016

Photo Number: 216

Description: Looking northwest at the southern side of Tank 6. Presence of water ponding.



APPENDIX F1 BAKER LAKE TANK FARM PHOTOGRAPHIC LOG



Photograph F1-19 Baker Lake Tank Farm

Date: September 11, 2016

Photo Number: 219

Description: Looking southeast at the northeastern side of Tank 6. Presence of water ponding.



Photograph F1-20 Baker Lake Tank Farm

Date: September 11, 2016

Photo Number: 220

Description: Looking south between Tanks 5 and 6. Presence of water ponding.



APPENDIX F1
BAKER LAKE TANK FARM PHOTOGRAPHIC LOG



Photograph F1-21 Baker Lake Tank Farm

Date: September 11, 2016

Photo Number: 221

Description: Looking west at the northeastern side of Tank 5.



Photograph F1-22 Baker Lake Tank Farm

Date: September 11, 2016

Photo Number: 223

Description: From the northeastern corner of the Jet A fuel tanks looking south. Presence of exposed geomembrane.



APPENDIX F1 BAKER LAKE TANK FARM PHOTOGRAPHIC LOG



Photograph F1-23 Baker Lake Tank Farm

Date: September 11, 2016

Photo Number: 222

Description: From the northeastern corner of the Jet A fuel tanks looking west. Presence of exposed geomembrane.



Photograph F1-24 Baker Lake Tank Farm

Date: September 11, 2016

Photo Number: 224

Description: From the southwestern corner of the Jet A fuel tanks looking east. Presence of exposed geomembrane and water ponding.



APPENDIX F1 BAKER LAKE TANK FARM PHOTOGRAPHIC LOG



Photograph F1-25 Baker Lake Tank Farm

Date: September 11, 2016

Photo Number: 225

Description: From the southwestern corner of the Jet A fuel tanks looking north. Presence of exposed geomembrane and water ponding.

n:\actif\2016\3 proj\1662181 aem geotech insp 2016 meadowbank\5 preparation of deliverables\doc 1549 2016 geotechnical inspection\rev 0\3 appendices\appendix f - bulk fuel facilities\1 baker lake tank\1-baker lake photo log 2016.docx



APPENDIX F2

Meadowbank Tank Farm Photographic Log

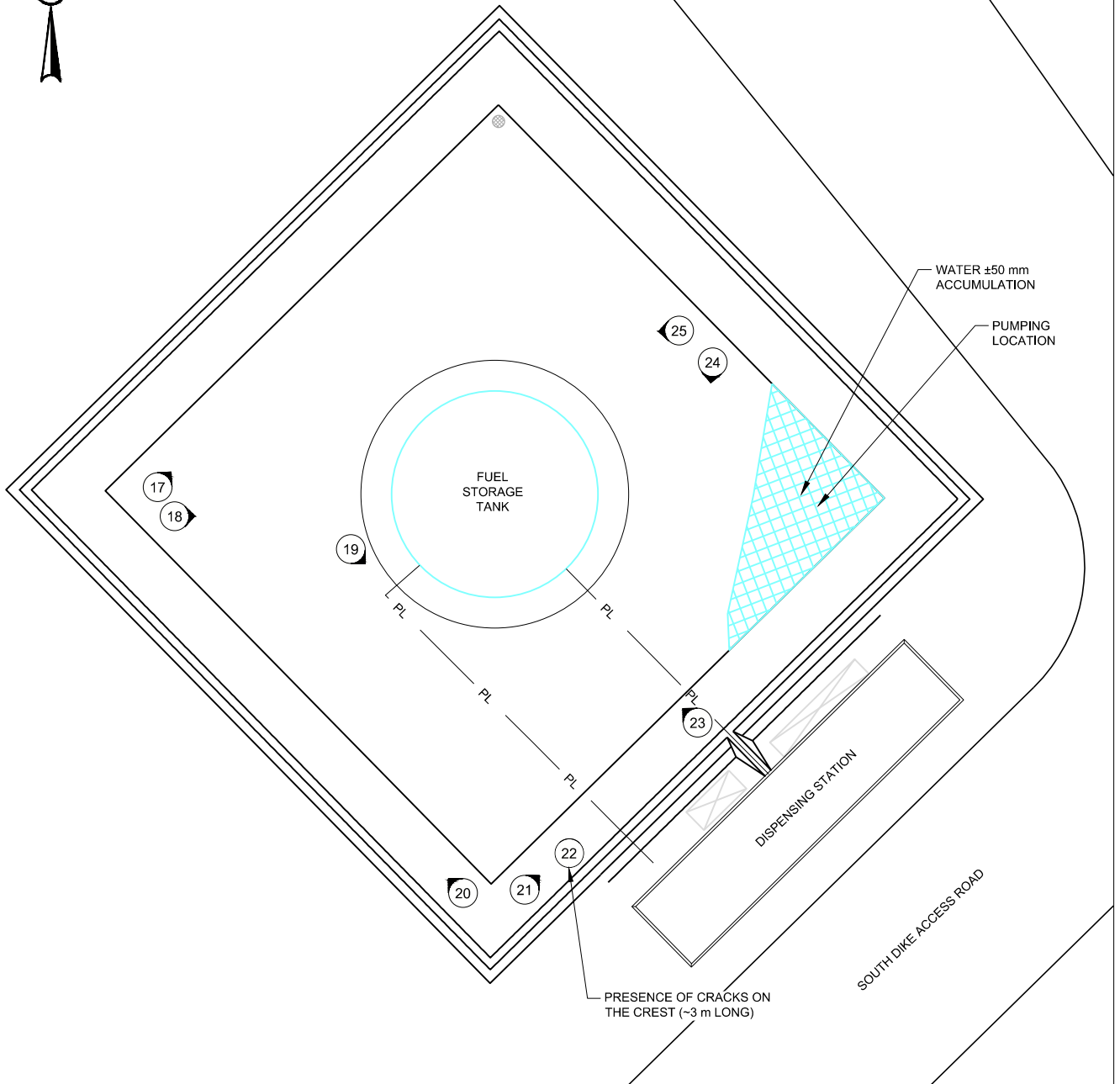

LEGEND



IDENTIFICATION AND DIRECTION OF PHOTOGRAPHY TAKEN DURING THE ANNUAL INSPECTION OF 2015

REFERENCE

BASE PLAN INFORMATION IS PROVIDED BY CUMBERLAND DATED FEBRUARY 03, 2008



CLIENT

PROJECT
2016 ANNUAL GEOTECHNICAL INSPECTION
MEADOWBANK GOLD MINE, NUNAVUT

CONSULTANT

YYYY-MM-DD 2017-02-06

PREPARED F. L. Bolduc

DESIGN S. Betnesky

REVIEW F. L. Bolduc

APPROVED Y. Boulianne

TITLE

TANK FARM MEADOWBANK

PROJECT No.
1662181

PHASE
4000

Rev.
0

FIGURE
F2





APPENDIX F2
MEADOWBANK TANK FARM PHOTOGRAPHIC LOG



Photograph F2-1 Meadowbank Tank Farm

Date: September 9, 2016

Photo Number: 18

Description: From the western corner, looking east at the tank.



Photograph F2-2 Meadowbank Tank Farm

Date: September 9, 2016

Photo Number: 17

Description: From the western corner, looking northeast at the tank.



APPENDIX F2 MEADOWBANK TANK FARM PHOTOGRAPHIC LOG



Photograph F2-3 Meadowbank Tank Farm

Date: September 9, 2016

Photo Number: 25

Description: From the eastern side, looking northwest.



Photograph F2-4 Meadowbank Tank Farm

Date: September 9, 2016

Photo Number: 24

Description: From the eastern side looking southwest. Presence of water ponding. A pump is installed.



APPENDIX F2 MEADOWBANK TANK FARM PHOTOGRAPHIC LOG



Photograph F2-5 Meadowbank Tank Farm

Date: September 9, 2016

Photo Number: 21

Description: Looking northeast from the southern corner. Accumulation of water in the eastern corner.



Photograph F2-6 Meadowbank Tank Farm

Date: September 9, 2016

Photo Number: 20

Description: Looking northwest from the southern corner.



APPENDIX F2
MEADOWBANK TANK FARM PHOTOGRAPHIC LOG



Photograph F2-7 Meadowbank Tank Farm

Date: September 9, 2016

Photo Number: 23

Description: Looking northwest from the northeastern side. Accumulation of water on the east side.



Photograph F2-8 Meadowbank Tank Farm

Date: September 9, 2016

Photo Number: 19

Description: From the southwestern side of the Tank, looking southeast.



APPENDIX F2 MEADOWBANK TANK FARM PHOTOGRAPHIC LOG



Photograph F2-9 Meadowbank Tank Farm

Date: September 9, 2016

Photo Number: 22

Description: From the southern corner: presence of small tension cracks on the crest (about 3 m long).

n:\actif\2016\3 proj\1662181 aem geotech insp 2016 meadowbank\5 preparation of deliverables\doc 1549 2016 geotechnical inspection\rev 0\3 appendices\appendix f - bulk fuel facilities\2 main camp tank\2 - meadowbank photographic log 2016.docx



APPENDIX F3

Vault Tank Farm Photographic Log

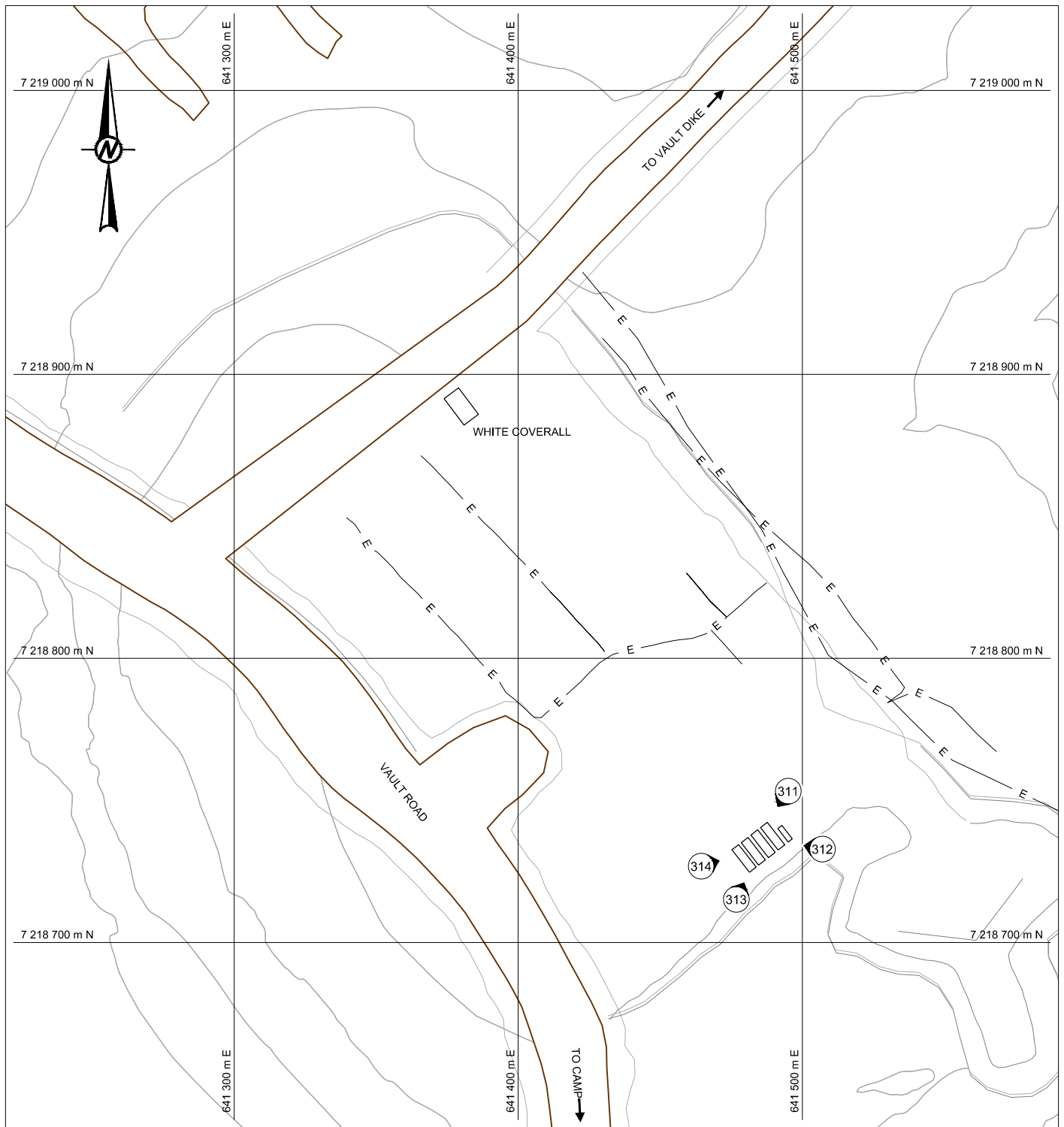

LEGEND



IDENTIFICATION AND DIRECTION OF PHOTOGRAPHY TOOK DURING THE ANNUAL INSPECTION OF 2015

REFERENCE

BASE PLAN INFORMATION IS PROVIDED BY CUMBERLAND DATED FEBRUARY 03, 2008



CLIENT

PROJECT
2016 ANNUAL GEOTECHNICAL INSPECTION
MEADOWBANK GOLD MINE, NUNAVUT

CONSULTANT

YYYY-MM-DD 2017-02-06

PREPARED F. L. Bolduc

DESIGN S. Betnesky

REVIEW F. L. Bolduc

APPROVED Y. Boulianne

TITLE

VAULT TANK FARM

PROJECT No.
1662181

PHASE
4000

Rev.
0

FIGURE
F3





APPENDIX F3 VAULT TANK FARM PHOTOGRAPHIC LOG



Photograph F3-1 Vault Tank Farm

Date: September 12, 2016

Photo Number: 312

Description: From the east corner of the Tanks looking northwest toward the Vault Tank Farm.



Photograph F3-2 Vault Tank Farm

Date: September 12, 2016

Photo Number: 314

Description: From the west corner of the Tanks Looking northeast toward the Vault Tank Farm.



APPENDIX F3 VAULT TANK FARM PHOTOGRAPHIC LOG



Photograph F3-3 Vault Tank Farm

Date: September 12, 2016

Photo Number: 313

Description: From the south corner of the Tanks Looking northeast toward the Vault Tank Farm.



Photograph F3-4 Vault Tank Farm

Date: September 12, 2016

Photo Number: 311

Description: From the north corner of the Tanks looking southwest toward the Vault Tank Farm.

n:\actif\2016\3 proj\1662181 aem geotech insp 2016 meadowbank\5 preparation of deliverables\doc 1549 2016 geotechnical inspection\rev 0\3 appendices\appendix f - bulk fuel facilities\3 vault tank\3 - vault tank photographic log 2016.docx



APPENDIX G

Other Site Facilities

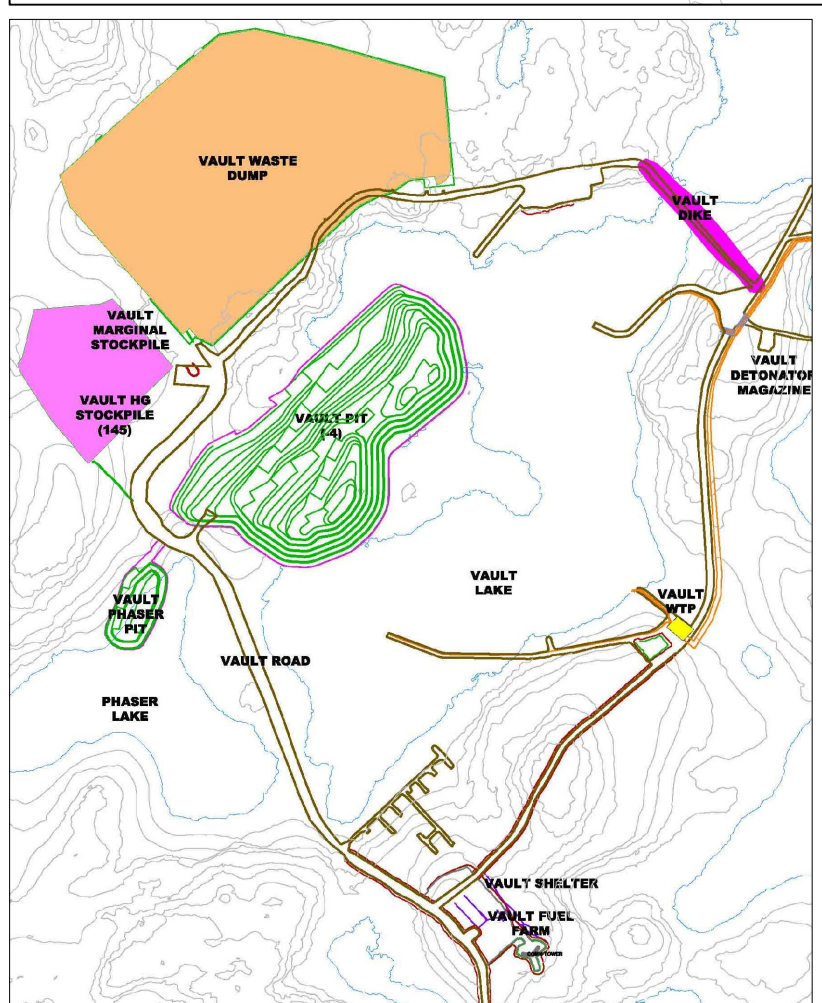
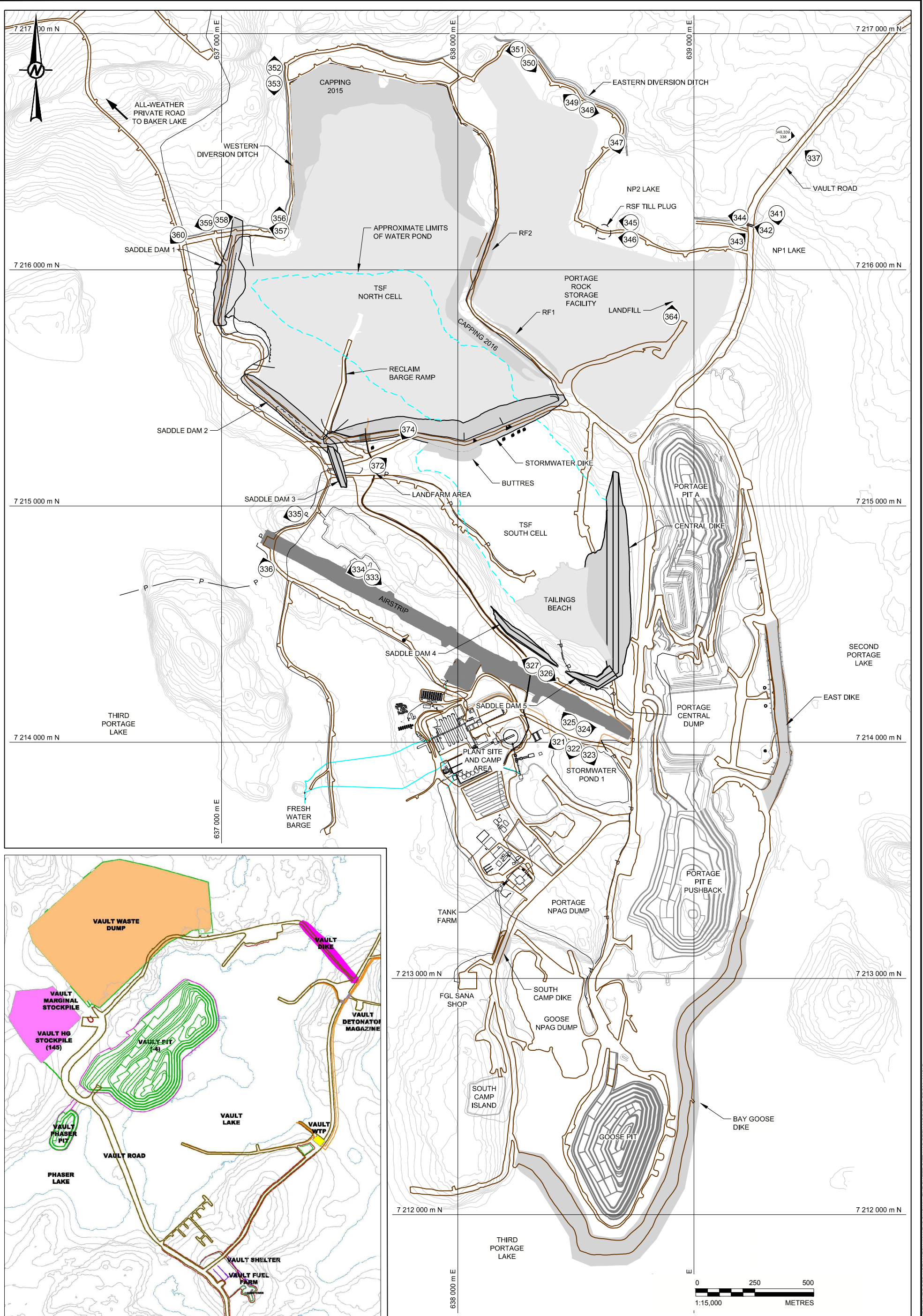

LEGEND
 _____ TOPOGRAPHIC CONTOUR

NOTE
 GRID REFERENCE: NAD 83, UTM ZONE 14.

REFERENCE
 DRAWING BASE PROVIDED BY AEM LTD., MEADOWBANK DIVISION
 IN "MBK Site map updated JULY 2014.dwg" DATED JULY 8, 2014.

CLIENT

AGNICO EAGLE

CONSULTANT

Golder Associates

PROJECT
 2016 ANNUAL GEOTECHNICAL INSPECTION
 MEADOWBANK GOLD MINE, NUNAVUT

TITLE
MEADOWBANK MINE SITE

YYYY-MM-DD	2017-02-06
PREPARED	F. L. Bolduc
DESIGN	S. Betnesky
REVIEW	F. L. Bolduc
APPROVED	Y. Boulianne

PROJECT No.	1662181	PHASE	4000	Rev.	0	FIGURE	G1
-------------	---------	-------	------	------	---	--------	----



APPENDIX G1

Vault Road Culverts Photographic Log



APPENDIX G1 VAULT ROAD CULVERTS PHOTOGRAPHIC LOG



Photograph G1-1 Vault Road Culverts

Date: September 13, 2016

Photo Number: 337

Description: Looking at the outlet of the three culverts located on Vault Road at 640964E/7217466N. All of them are deformed in the middle.



Photograph G1-2 Vault Road Culverts

Date: September 13, 2016

Photo Number: 340

Description: From the inlet side of the three culverts located on Vault Road at 640964E/7217466N. Looking inside the southern culvert. The culvert is slightly deformed on top in the middle.



APPENDIX G1 VAULT ROAD CULVERTS PHOTOGRAPHIC LOG



Photograph G1-3 Vault Road Culverts

Date: September 13, 2016

Photo Number: 339

Description: From the inlet side of the three culverts located on Vault Road at 640964E/7217466N. Looking inside the central culvert. The culvert is slightly deformed on top in the middle.



Photograph G1-4 Vault Road Culverts

Date: September 13, 2016

Photo Number: 338

Description: From the inlet side of the three culverts located on Vault Road at 640964E/7217466N. Looking inside the northern culvert. The culvert is slightly deformed on top in the middle.



APPENDIX G1 VAULT ROAD CULVERTS PHOTOGRAPHIC LOG



Photograph G1-5 Vault Road Culverts

Date: September 13, 2016

Photo Number: 342

Description: Culvert on the NP1 side at 639 214 E / 7 216 189 N on Vault Road. Culvert broken and partially obstructed.



Photograph G1-6 Vault Road Culverts

Date: September 13, 2016

Photo Number: 343

Description: Culvert on the NP2 side at 639 214 E / 7 216 189 N on Vault Road. Southern culvert is collapsed.

n:\actif\2016\3 proj\1662181 aem geotech insp 2016 meadowbank\5 preparation of deliverables\doc 1549 2016 geotechnical inspection\rev 0\3 appendices\appendix g - other facilities\g1 - vault road culvert\g1-vault culvert photo log 2016.docx



APPENDIX G2

Diversion Ditch and Sediment and Erosion Control Structure Photographic Log



APPENDIX G2 DIVERSION DITCH AND ITS EROSION AND SEDIMENT PROTECTION STRUCTURE PHOTOGRAPHIC LOG



Photograph G2-1 Diversion Ditch and its Sediment and Erosion Protection Structure

Date: September 13, 2016

Photo Number: 341

Description: Looking south toward Lake NP1 at the sediment and erosion protection structure. Presence of 2 silt curtains and 3 wooden barrier.



Photograph G2-2 Diversion Ditch and its Sediment and Erosion Protection Structure

Date: September 13, 2016

Photo Number: 347

Description: From the eastern diversion ditch looking south toward Lake NP2.



APPENDIX G2
DIVERSION DITCH AND ITS EROSION AND SEDIMENT PROTECTION
STRUCTURE PHOTOGRAPHIC LOG



Photograph G2-3 Diversion Ditch and its Sediment and Erosion Protection Structure

Date: September 13, 2016

Photo Number: 348

Description: From the eastern diversion ditch, looking east.



Photograph G2-4 Diversion Ditch and its Sediment and Erosion Protection Structure

Date: September 13, 2016

Photo Number: 349

Description: From the eastern diversion ditch, looking northwest.



APPENDIX G2
DIVERSION DITCH AND ITS EROSION AND SEDIMENT PROTECTION
STRUCTURE PHOTOGRAPHIC LOG



Photograph G2-5 Diversion Ditch and its Sediment and Erosion Protection Structure

Date: September 13, 2016

Photo Number: 350

Description: From the northern diversion ditch looking southeast.



Photograph G2-6 Diversion Ditch and its Sediment and Erosion Protection Structure

Date: September 13, 2016

Photo Number: 351

Description: From the northern diversion ditch looking west.



APPENDIX G2

DIVERSION DITCH AND ITS EROSION AND SEDIMENT PROTECTION STRUCTURE PHOTOGRAPHIC LOG



Photograph G2-7 Diversion Ditch and its Sediment and Erosion Protection Structure

Date: September 13, 2016

Photo Number: 352

Description: From 637281E/7216790N, looking north. View of the western diversion ditch.



Photograph G2-8 Diversion Ditch and its Sediment and Erosion Protection Structure

Date: September 13, 2016

Photo Number: 353

Description: From 637281E/7216790N, looking south at the western diversion ditch.



APPENDIX G2 DIVERSION DITCH AND ITS EROSION AND SEDIMENT PROTECTION STRUCTURE PHOTOGRAPHIC LOG



Photograph G2-9 Diversion Ditch and its Sediment and Erosion Protection Structure

Date: September 13, 2016

Photo Number: 356

Description: From 637251E/7216171N, looking north at the western diversion ditch.



Photograph G2-10 Diversion Ditch and its Sediment and Erosion Protection Structure

Date: September 13, 2016

Photo Number: 357

Description: From 637251E/7216171N, looking west at the western diversion ditch and its retention basin.



APPENDIX G2 DIVERSION DITCH AND ITS EROSION AND SEDIMENT PROTECTION STRUCTURE PHOTOGRAPHIC LOG



Photograph G2-11 Diversion Ditch and its Sediment and Erosion Protection Structure

Date: September 13, 2016

Photo Number: 358

Description: From 637074E/7216157N, looking east at the western diversion ditch.



Photograph G2-12 Diversion Ditch and its Sediment and Erosion Protection Structure

Date: September 13, 2016

Photo Number: 359

Description: From 637074E/7216157N, looking west at the western diversion ditch.

n:\actif\2016\3 proj\1662181 aem geotech insp 2016 meadowbank\5 preparation of deliverables\doc 1549 2016 geotechnical inspection\rev 0\3 appendices\appendix g - other facilities\g2 - diversion ditch\g2-diversion ditch photo log 2016.docx



APPENDIX G3

RSF Till Plug Photographic Log



APPENDIX G4 LANDFILL PHOTOGRAPHIC LOG



Photograph G3-1 RSF Till Plug

Date: September 13, 2016

Photo Number: 345

Description: From the south side of NP2 Lake (north of the diversion ditch) looking west at the RSF till plug.



Photograph G3-2 RSF Till Plug

Date: September 13, 2016

Photo Number: 346

Description: From the south side of NP2 Lake (south of the diversion ditch) looking west at the RSF till plug.

n:\acil\2016\3 proj\1662181 aem geotech insp 2016 meadowbank\5 preparation of deliverables\doc 1549 2016 geotechnical inspection\rev 0\3 appendices\appendix g - other facilities\g3- rsf till plug\g3 - rsf till plug photo log 2016.docx



APPENDIX G4

Diffusers Photographic Log



APPENDIX G3 DIFFUSERS PHOTOGRAPHIC LOG



Photograph G4-1 Diffusers – Wally Lake Diffuser

Date: September 12, 2016

Photo Number: 306

Description: Looking at the Wally Lake Diffuser. The pipe is not anchored at the bottom of the lake.



Photograph G4-2 Diffusers – Wally Lake Diffuser

Date: September 12, 2016

Photo Number: 308

Description: Looking at the Wally Lake Diffuser. The pipe is not anchored at the bottom of the lake.

n:\actif\2016\3 proj\1662181 aem geotech insp 2016 meadowbank\5 preparation of deliverables\doc 1549 2016 geotechnical inspection\rev 0\3 appendices\appendix g - other facilities\g4 - diffusers\g4-diffusers photo log 2016.docx



APPENDIX G5

Landfill Photographic Log



APPENDIX G4 LANDFILL PHOTOGRAPHIC LOG



Photograph G5-1 Landfill

Date: September 13, 2016

Photo Number: 364

Description: From 638857E/7215767N , looking north at the landfill.

n:\acif\2016\3 proj\1662181 aem geotech insp 2016 meadowbank\5 preparation of deliverables\doc 1549 2016 geotechnical inspection\rev 0\3 appendices\appendix g - other facilities\g5 - landfill\g5 - landfill photographic log 2016 - copie.docx



APPENDIX G6

Contaminated Soil Storage and Bioremedial Landfarm Facility Photographic Log



APPENDIX G5 CONTAMINATED SOIL STORAGE AND BIOREMEDIATION LANDFARM FACILITY PHOTOGRAPHIC LOG



Photograph G6-1 Contaminated Soil Storage and Bioremediation Landfarm Facility

Date: September 13, 2016

Photo Number: 374

Description: Looking southwest at the Contaminated Soil Storage and Bioremediation Landfarm Facility located within the South Cell of the TSF.



Photograph G6-2 Contaminated Soil Storage and Bioremediation Landfarm Facility

Date: September 13, 2016

Photo Number: 372

Description: From the WTP, looking northeast at the Contaminated Soil Storage and Bioremediation Landfarm Facility located within the South Cell of the TSF.

n:\actif\2016\3 proj\1662181 aem geotech insp 2016 meadowbank\5 preparation of deliverables\doc 1549 2016 geotechnical inspection\rev 0\3 appendices\appendix g - other facilities\g6 - landfarm\g6 - landfarm photo log 2016.docx



APPENDIX G7

Stormwater Management Pond Photographic Log



APPENDIX G7 STORMWATER POND PHOTOGRAPHIC LOG



Photograph G7-1 Stormwater Pond

Date: September 13, 2016

Photo Number: 321

Description: From the northern side of the pond, looking west at Stormwater Pond and crusher ramp.



Photograph G7-2 Stormwater Pond

Date: September 13, 2016

Photo Number: 322

Description: From the northern side of the pond, looking south at Stormwater Pond and the crusher ramp.



APPENDIX G7 STORMWATER POND PHOTOGRAPHIC LOG



Photograph G7-3 Stormwater Pond

Date: September 13, 2016

Photo Number: 323

Description: From the northern side of the pond, looking southeast at Stormwater Pond.

n:\actif\2016\3 proj\1662181 aem geotech insp 2016 meadowbank\5 preparation of deliverables\doc 1549 2016 geotechnical inspection\rev 0\3 appendices\appendix g - other facilities\g7 - stormwater pond\g7 stormwater pond photo log 2016.docx



APPENDIX G8

Airstrip Photographic Log



APPENDIX G8
AIRSTRIP PHOTOGRAPHIC LOG



Photograph G8-1 Airstrip

Date: September 13, 2016

Photo Number: 335

Description: Looking west at the extremity of the airstrip located within Third Portage Lake.



Photograph G8-2 Airstrip

Date: September 13, 2016

Photo Number: 336

Description: Looking north at the extremity of the airstrip located within Third Portage Lake.



APPENDIX G8 AIRSTRIP PHOTOGRAPHIC LOG



Photograph G8-3 Airstrip

Date: September 13, 2016

Photo Number: 334

Description: From the northwest side of the airstrip looking west.



Photograph G8-4 Airstrip

Date: September 13, 2016

Photo Number: 333

Description: From the northwest side of the airstrip looking southeast.



APPENDIX G8
AIRSTRIP PHOTOGRAPHIC LOG



Photograph G8-5 Airstrip

Date: September 13, 2016

Photo Number: 327

Description: From the northeast side of the airstrip looking northwest.



Photograph G8-6 Airstrip

Date: September 13, 2016

Photo Number: 326

Description: From the northeast side of the airstrip looking southeast.



APPENDIX G8 AIRSTRIP PHOTOGRAPHIC LOG



Photograph G8-7 Airstrip

Date: September 13, 2016

Photo Number: 325

Description: From the southeast side of the airstrip looking northwest.



Photograph G8-8 Airstrip

Date: September 13, 2016

Photo Number: 324

Description: From the southeast side of the airstrip looking east.

n:\act\2016\3 proj\1662181 aem geotech insp 2016 meadowbank\5 preparation of deliverables\doc 1549 2016 geotechnical inspection\rev 0\3 appendices\appendix g - other facilities\g8 - airstrip\g8 airstrip photo log 2016.docx

At Golder Associates we strive to be the most respected global company providing consulting, design, and construction services in earth, environment, and related areas of energy. Employee owned since our formation in 1960, our focus, unique culture and operating environment offer opportunities and the freedom to excel, which attracts the leading specialists in our fields. Golder professionals take the time to build an understanding of client needs and of the specific environments in which they operate. We continue to expand our technical capabilities and have experienced steady growth with employees who operate from offices located throughout Africa, Asia, Australasia, Europe, North America, and South America.

Africa	+ 27 11 254 4800
Asia	+ 86 21 6258 5522
Australasia	+ 61 3 8862 3500
Europe	+ 356 21 42 30 20
North America	+ 1 800 275 3281
South America	+ 55 21 3095 9500

solutions@golder.com
www.golder.com

Golder Associés Ltée
7250, rue du Mile End, 3e étage
Montréal (Québec) H2R 3A4
Canada
T: +1 (514) 383 0990





AGNICO EAGLE

March 29th, 2017

M. Karén Kharatyan
Technical Advisor
Nunavut Water Board
P.O. Box 119
Gjoa Haven, NU
X0B 1J0
(867) 360-6338

Re: Meadowbank Water License 2AM-MEA1525 Part I, Item 11 – 2016 Annual Geotechnical Inspection Report

Dear M. Kharatyan,

Agnico Eagle Mine Ltd. received the report “*2016 Annual Geotechnical Inspection Meadowbank Gold Mine, Nunavut*”. An electronically and paper copy of this report will be send to your office via Xpresspost, as required by Water license 2AM-MEA1525 Part I, Item 11, as an Appendix of the 2016 Annual Report due on March 31st, 2017.

Please consider the following information as the implementation plan to address the recommendations in Section 9.0 of the report.

Should you have any question, please do not hesitate to contact me at the below.

Regards,

Agnico Eagle Mines Limited – Meadowbank Division

Marie-Pier Marcil
marie-pier.marcil@agnicoeagle.com
819-759-3700 x5193
Senior Compliance Technician

Table of Contents

1	DEWATERING DIKES.....	3
1.1	East Dike	3
1.2	South Camp Dike.....	3
1.3	Bay-Goose Dike	4
1.4	Vault Dike	5
2	TAILINGS STORAGE FACILITY.....	7
2.1	Saddle Dam 1.....	7
2.2	Saddle Dam 2.....	8
2.3	Stormwater Dike.....	8
2.4	Central Dike	9
2.5	Saddle Dam 3 and 4	10
3	AWAR.....	11
4	QUARRIES	13
5	BULK FUEL STORAGE FACILITIES	14
6	OTHER MEADOWBANK FACILITIES	16
6.1	Meadowbank Site Roads.....	16
6.2	Diversion Ditch and Sediment and Erosion Protection Structure.....	16
6.3	Diffuser	16
6.4	Stormwater Management Ponds.....	17

1 DEWATERING DIKES

Recommendation: The current versions of the Operation, Maintenance and Surveillance (OMS) Manual (AEM, 2016), including the Emergency Preparedness Plan (EPP), and of the overall Emergency Response Plan (ERP) for the mine (AEM, 2016c) are dated March 2016 and August 2016. It is a good practice to keep these documents up to date.

Action: Agnico will continue to keep the Dewatering Dikes OMS Manual up to date. The last update of the Dewatering Dikes OMS Manual is dated March 2016. The last update of the ERP is dated January 2017.

Recommendation: The condition of the dewatering dikes is regularly inspected by the mine and this practice should continue.

Action: As stated in the Dewatering Dikes OMS manual, Agnico will continue to inspect and monitor all the dewatering dikes on a monthly basis.

1.1 East Dike

Recommendation: Regular monitoring and assessment of the monitoring data (piezometric, thermal, inclinometer, flow meter and seismograph) should continue. Due to technical problems with datalogger, the piezometer and thermistor data from June 2016 to September 2016 are missing between Sta.60+240 and 60+700. As a result, partial pore water pressure or temperature data are available for the thawing period of 2016. It is recommended to fix the issue with these instruments to continue obtaining data. It is recommended to flag the piezometers that recorded data below 0°C in the past and be very careful when interpreting their data as they might be broken

Action: The monitoring and data interpretation of the instrumentation at East Dike is done on a regular basis and will continue. A dewatering dike instrumentation report is prepared every month by the engineering department.

1.2 South Camp Dike

Recommendation: It is recommended to continue keeping the downstream toe of the dike clear to facilitate inspection. The nearby ultramafic rock dump should not obstruct the toe of the dike.

Action: The nearest NPAG material placed on the downstream side of the South Camp Dike is at a distance of 10 m from the toe of the dike, in order to keep the area clear to facilitate inspection.

1.3 Bay-Goose Dike

Recommendation: The tension cracks observed in 2013 and 2014 on the upstream side within the thermal cap were still visible but are no longer active. The settlement within the thermal cap was observed but did not show any additional sign of movement since 2013. The area should continue to be monitored to make sure there are no aggravating conditions developing.

Action: The monitoring of the entire dike will continue on a regular basis, emphasis will be put on the spring freshet period. Visual inspection is performed every week during that period.

Recommendation: Regular monitoring and assessment of the monitoring data (piezometric, flow, thermal, inclinometer, and seismograph) should continue. It is recommended to flag the piezometers that recorded data below 0°C in the past and be very careful when interpreting their data as they might be broken. Once a piezometer has frozen, it cannot be relied upon even if it thaws.

Action: The monitoring of the instrumentation at Bay Goose Dike is done on a regular basis and will continue. The monitoring of the instrumentation at Bay Goose Dike is completed on a regular basis and will continue. A register of all the broken instruments is filed on a monthly basis in the Dewatering dikes instrumentation report.

Recommendation: Water ponds were observed at the downstream toe during the inspection. It is recommended to pump them periodically to allow for good visual inspection of the downstream toe. The pond flow formed by seepage should be monitored and recorded.

Action: The monitoring of the water ponds at the downstream toe of the dike will continue on a regular basis during the open water season. Pumping of the ponds is done as needed, normally 3-4 times during open water season depending on rain events.

Recommendation: Overall seepage is less than anticipated and is not a concern for now. The inflow of water from the pond at Central Channel should be monitored.

Action: The monitoring and flow measurement of the seepages along the downstream toe will continue as a part of our regular inspection and daily routine.

Recommendation: North Channel, Channel 1 and Channel 3 should be carefully monitored and inspected. Limited evidence of seepage is observed at the downstream toe of these channels. The instrumentation data and field observations seem to indicate that seepage occurs at these locations but reports directly to the Pits instead of the downstream toe area. The seepage being reported to the Pits should be included in the Bay-Goose Dike seepage statistics.

Action: Water inflow from the bedrock formations in the Goose pit (not considered as seepage) is coming from various locations around the pit and is not always associated with the Bay-Goose Dike. During mining operation at Goose pit, all the water from Goose pit was pumped into a collection sump and a flowmeter was installed on the pipe between this sump and the discharge in the Attenuation Pond. Therefore, it was not possible to differentiate the quantity of water coming from underneath the dike (seepage) with the water coming from the groundwater (talik). As the mining activities have ceased in the Goose pit, the water from some seepage and from the groundwater inflows are directed to Goose Pit as pumping is no longer required. Flooding rate is evaluated by scanning the Goose pit and monthly water volume evaluated with reflooding curve.

Recommendation: Further assessment is required to assess the impact of Portage Pit mining on the stability of Bay-Goose Dike as the North Channel piezometer seems to react to E3/E4 activity. This assessment is underway by AEM.

Action: This assessment is underway by Agnico. Dike designer has already provided insights on the design criteria's used for the Bay Goose Dike cutoff wall. A complimentary instrumentation campaign will be completed in the months to come to monitor the stability of the Pit slope as well as the temperature and hydraulic conditions of the bedrock and overburden at the toe of the dike. The instruments already installed within the dike and its foundation will continue to be monitored closely by the Geotech team. A procedure was put in place to inspect the dike and the surroundings after each blast done in the Pit E Pushback area.

1.4 Vault Dike

Recommendation: Vault Dike was in good condition at the time of the inspection. The settlement and cracks observed in 2013 and 2014 were not noticeable anymore. No new issues were observed.

Action: The hole observed during the 2013 inspection was plugged before winter

Recommendation: Regular monitoring and assessment of the thermistor data should continue.

Action: The monitoring and data analysis of the instrumentation at Vault Dike is done on a weekly basis and will continue.

2 TAILINGS STORAGE FACILITY

Recommendation: The most current versions of the Operation, Maintenance and Surveillance (OMS) Manual (AEM, 2016b), including the Emergency Preparedness Plan (EPP), and of the overall Emergency Response Plan (ERP) for the mine (AEM, 2016c) are dated March 2016 and August 2016. It is a good practice to keep these documents up to date.

Action: Agnico will continue to keep the TSF OMS Manual up to date. The last update of the TSF OMS Manual is dated March 2016. The last update of the ERP is dated January 2017

Recommendation: At the time of the inspection, the peripheral structures of the TSF North Cell had an adequate tailings beach against them. Water was observed ponding against the northern portion of Central Dike as tailings deposition from Central Dike was stopped during the 2016 construction season. Agnico is planning to quickly restore the tailings beach against Central Dike per the design requirement.

Action: The tailings deposition in the North Cell was completed in October 2015. The peripheral structures of the cell, including the Stormwater Dike presented adequate tailings beaches. It is also important to note that during the summer 2015, the water from the North Cell pond was transferred to the South Cell as the reclaim water system was located in the South Cell. Until North Cell TSF capping will be completed water elevation will be maintained under 148masl. The gap in tailings beach against the structure of the Central Dike was completely filled at the beginning of 2017.

Recommendation: Regular visual inspection as well as collection and regular review of instrument data should continue for all structures within the TSF.

Action: Inspection of the TSF structures are conducted on a monthly basis and will continue.

2.1 Saddle Dam 1

Recommendation: The environmental department should continue monitoring the water quality and share this information with the engineering department.

Action: The water quality is monitored at the downstream toe of Saddle Dam 1 (monitoring station ST-S-2). The water sampling is conducted monthly at ST-S-2

during open water season. The sampling results are reviewed by the environment department and shared with the engineering department.

2.2 Saddle Dam 2

Recommendation: Water was observed on the downstream side ponding within the rockfill embankment between Sta. 20+275 and Sta. 20+475. It is recommended to install a thermistor within this sector and to be on the lookout for signs of change in the thermal regime of the foundation.

Action: The results of the thermistors located in Saddle Dam 2 are reviewed on a regular basis to detect any change or anomaly in temperature trend within the structure. No trend indicating changes in the thermal regime of Saddle Dam 2 have been observed to date. Review of the thermistors results will continue.

2.3 Stormwater Dike

Recommendation: Several tension cracks associated with movement were observed on the crest from Sta. 10+500 to 10+750. These movements appeared in August 2016 shortly after water from the South Cell reached this sector and stabilized, then stopped shortly after a rockfill buttress was constructed at the toe on the downstream side in September 2016. The observed movements are happening in a sector where the dike was built on frozen soft sediment and were probably caused by the water thawing this soft layer. The MDRB recommended that more instruments be installed, that a better understanding of the foundation be obtained through a geotechnical investigation, and that design criteria be established for the mitigation measure put in place.

Action: In January 2017, Agnico underwent a 3 holes geotechnical investigation with material sampling and instruments installation in the area the movements happened. 2 Holes were targeting the materials within the buttress foundation and another hole was installed in the tailings on the upstream side of the dike. The campaign aimed to better characterize the materials and assess it in-situ conditions. Thermistors and piezometers were installed and currently monitored daily by AEM. The long term stability of the Stormwater Dike is currently being assessed by GAL and a report will be emitted shortly.

Recommendation: Shallow water (30 cm deep) was observed ponding against a portion of Stormwater Dike in the North Cell. This small accumulation of water against the dike is not considered a problem.

Action: That small amount of water ponding against is formed from heavy fall precipitations and is not judge critical by Agnico.

Recommendation: A small hole in the bituminous geomembrane was observed at approximately Sta. 10+200. A punctured water balloon in the liner was also observed at 10+380. These two areas were repaired after the inspection.

Action: Holes on the Coletanche geomembrane are easily fixed by Agnico personnel every time they are found. AEM consider these holes not a threat to the environment since tailings deposition in front of the Stormwater dike structure have reached its final elevation.

2.4 Central Dike

Recommendation: Tailings deposition from Central Dike stopped during the 2016 construction season. Tailings deposition from the structure was planned to resume in October 2016 to promote a tailings beach against the structure.

Action: The tailings deposition in the South Cell resumed on North section on October 16th 2016 and a complete beach against the liner was observed in January 2017.

Recommendation: Seepage from the South Cell is ponding on the downstream side of Central Dike. At the time of the inspection, the water was clear and an average flow of approximately 550 m³/hr was pumped back to the South Cell to maintain the downstream pond at El. 115 m. AEM is working closely with the MDRB and the dike designer (Golder) to determine the seepage pathway and to establish measures to keep the situation under control. Golder recommends: 1) maintaining a tailings beach against Central Dike, 2) controlling the hydraulic gradient by proper management of the South Cell water pond and dike downstream toe pond, 3) closely monitoring the water quality; and 4) inspecting the structure for changing conditions.

Action:

- 1) *According to the latest deposition plan, a complete beach will remain in front of the liner of CD for the entire 2016 season.*
- 2) *The level of the downstream pond is maintained since the end of October 2015 to a 115m elevation which is controlled by pumping the seepage water back to the South Cell.*
- 3) *A weekly sampling program has been implemented to follow up on the water quality of the seepage, as well as a daily turbidity assessment. All data is communicated to the Engineering department. New instruments have been added to the West Road to monitor its condition and are read on a regular basis.*

- 4) *Daily inspection of the Central Dike downstream toe is done by the AEM personnel.*

2.5 Saddle Dam 3 and 4

Recommendation: During the inspection, water was observed ponding on the downstream side of Saddle Dam 3 and Saddle Dam 4. As the downstream toe is higher than the South Cell pond, this water does not come from the TSF. It is important to maintain the water level on the downstream side lower than the granular layer of the upstream toe liner tie-in granular material to prevent uplift of the geomembrane. As the elevation of the downstream side is lower than the elevation of the granular material, this should not be a problem if the downstream water level is managed. The management of this water could be simplified by the construction of a sump, as indicated in the construction drawings, to direct the water in a low point.

Action: As these structures are still in construction phase, the sump that figure on the plans issued for construction won't be built for the moment. Water in these areas is managed, at spring freshet and during construction season, by pumping it back to the tailings pond. These sumps will be built as part of the Water Management of the Closure of the mine site.

3 AWAR

Recommendation: Regular inspections and maintenance of the road by AEM should continue. Consideration should be given to expanding AEM's monitoring program to include all culverts and bridges along the road in order to assess whether they are providing adequate capacity during the freshet and following large precipitation events.

Action: AWAR road crews remove ice and snow from all culverts and bridges before the freshet. Some culverts were added to prevent road washout. A weekly environmental inspection is conducted on the AWAR which includes all, the bridges and the culverts. Additional inspections on the bridges and culverts are also performed during the freshet period.

Recommendation: AEM has been conducting regular and event-based inspections of the fish-bearing water crossing locations along the road and these should continue in order to confirm the hydraulic function of the crossings, adequacy of crossing locations with respect to the watercourses, and minimal impact to fish habitat.

Action: The environment department monitors and inspects the bridges during the weekly AWAR inspections. During freshet and summer periods, Agnico conducts fish monitoring every two years. The last fisheries monitoring program was conducted during summer 2015. In summer 2017, another fisheries program is planned. Results of the program will be available in the Meadowbank Annual Report 2017.

Recommendation: The erosion of the culverts is stable. The progression of the erosion of culverts PC-17A (8+830), R14 (67+840), R18-B, R-20 (85+490), R-23(93+600) and R24 (98+100) should be monitored at freshet for any signs of progression or washout, as signs of water flowing beneath the road were observed at these locations.

Action: A weekly environmental inspection is conducted on the AWAR to inspect the bridges and the culverts. Additional inspections of the bridges and culverts are also performed during the freshet period to monitor signs of erosion and turbidity in the water. The Meadowbank Energy and Infrastructure Department also conducts inspections, especially during freshet period. Following the inspections, if work such as material placement for erosion control is deemed required around the culverts (stated in the above recommendation or for other culverts; the work will be completed by Agnico.

Recommendation: For some culvert locations, monitoring is recommended to see if flow occurs through the culvert (i.e. during the freshet). If insufficient capacity to handle the flows is observed, or water circulates under the road, then it is recommended to clear the obstructions or repair the culverts. Particular attention should be paid to R-00A (km 2+550), the culvert at 5+700, PC-14 (km 4+260), and PC-16 (km 54+950).

Action: The AWAR road crew removes ice and snow from all culverts and bridges before the freshet to ensure water flow. Some culverts were added to prevent road washout from occurring. A weekly environmental inspection is conducted on the AWAR to inspect the bridges and the culverts and additional inspections are also performed during the freshet period. Following the inspections, if work is deemed required such as culvert repair or replacement to prevent road washout, the work will be completed by Agnico.

Recommendation: The inspected bridges and their embankments were in good geotechnical condition. Signs of settlement were observed at Bridge 6, R15. The bridge was dipping toward the western side on both abutments. The bridge foundation did not show signs of adverse conditions. It is recommended to monitor the situation.

Action: A weekly environmental inspection is conducted on the AWAR to inspect the bridges and the culverts and additional inspections are also performed during the freshet period. The Meadowbank Energy and Infrastructure Department also conducts inspections, especially during freshet period. Following the inspections, if work is deemed required such as culvert repair or replacement to prevent road washout, the work will be completed by Agnico.

4 QUARRIES

Recommendation: Presence of unstable blocks and loose rocks along steep walls was observed in Quarries 3, 7, 9, 10, 12, 16, and 23. It is recommended that workers be cautious in these quarries and are aware of the potential hazard.

Action: If deemed necessary, additional work will be completed in 2017. The AWAR road crew will clean up unstable blocks and loose rocks should operations resume.

Recommendation: Most quarries have been cleaned since the 2015 inspection. Loose blocks and granular material have also been removed from the quarry walls. Slope remediation is in progress, but none of them were totally reclaimed. It is understood that AEM is developing a plan to progressively close some of the quarries along the AWPR while maintaining others to produce and store material supplies for ongoing road maintenance.

Action: The quarry reclamation along the AWAR is part of the Meadowbank Closure Plan. Reclamation activities for the quarries may occur during operations. The remaining reclamation activities for the quarries will occur during the closure period. As the AWAR will remain open during the closure and part of the post closure period, some quarries will remain open to supply material for ongoing road maintenance.

Recommendation: Quarry 4 and Quarry 14 are flooded. It is understood that AEM is evaluating how best to eliminate the ponding of water within these quarries.

Action: During the environmental inspections AWAR, the quarries are inspected. If actions are required for mitigation measures to control the water or to promote drainage, the Environmental department would advise the Energy and Infrastructure Department of actions to be taken. The water ponding at freshet or during the summer period in the quarries does not drain to any nearby watercourse. During previous summer periods (2014, 2015, 2016) no mitigation was deemed necessary as no significant amounts of water were observed in the quarries. During winter, the snow is also removed from the quarries to minimize water runoff at freshet within the quarry areas.

5 BULK FUEL STORAGE FACILITIES

Recommendation: Ponded water within the secondary containment cell was observed at the Baker Lake and Meadowbank main camp fuel tank farm. Ongoing removal of water should be managed to keep the water accumulation at a minimum near the tank foundation.

Action: Each year, the accumulated water is pumped out in accordance with the Type A Water License 2AM-MEA1525 (particularly after freshet and as needed during the open water season). Effluent must meet criteria stated in the License. After the water is pumped, each tank foundation is inspected.

Recommendation: The granular fill material protecting the geomembrane was eroded at Baker Lake due to wave actions in some areas, exposing the geomembrane. This condition was observed all along the south side of Tanks 3 and 4 and on the west side of Tank 1. It is recommended to cover the exposed area with geotextile and fill material to re-establish the liner protection.

Action: Repairs on the geomembrane close to tanks 3 and 4 was completed each year since summer 2015 by qualified contractors.

Recommendation: A hole in the exposed geomembrane (300 mm diameter hole) was observed at Baker Lake on the south southwestern corner of Tank 3 at the toe of the slope. The hole in the geomembrane should be repaired to ensure a good performance of the retention basin.

Action : Repair has been done in 2016 by the dewatering crew.

Recommendation: The embankments around the Baker Lake tank farm containment areas were stable. Tension cracks observed in the past on the upper bench north of Tanks 3 and 4 and south of Tanks 5 and 6 are disappearing. The northern slope of the containment area of Tanks 5 and 6 should be inspected periodically for signs of erosion.

Action: Regular inspections are completed at the fuel tank farm by the Energy and Infrastructures supervisor. Regular inspections are also completed by the environment department.

Recommendation: The geomembrane remains uncovered around the tanks of the twenty Jet A fuel tanks at Baker Lake. It is recommended to remain vigilant during the freshet and throughout the year to manage water accumulated within the bermed area.

Action: Water accumulation is monitored on a regular basis during freshet and pumped out in accordance with the Type A Water License 2AM-MEA1525. The geomembrane was repaired during summer 2015. The Jet A tankfarm is inspected regularly by the environment department.

Recommendation: A 3 m long tension crack was observed at the Meadowbank Main Camp tank farm on top of the subexcavated area behind the fueling station. It is recommended to monitor this area for changing conditions.

Action: Monitoring of the tension crack will continue to be observed.

6 OTHER MEADOWBANK FACILITIES

6.1 Meadowbank Site Roads

Recommendation: Three culverts were installed on Vault Road (coordinates 640 964 E / 7 217 466 N). As previously observed in past annual inspections, these three culverts were partially collapsed in the middle and showed signs of erosion at the inlet. This is currently not a significant issue, but it is recommended to monitor these culverts at freshet to ensure that they provide sufficient capacity and that erosion is not occurring.

Action: The area has been regularly monitored since the installation of the culverts in 2013 and no issues were identified at the location in regard to water flow, quality or erosion. The same inspections will be performed during the 2017 freshet.

Recommendation: Two culverts are installed on Vault Road (coordinate 639214E/7216189N). It was observed that the inlet of one of the culvert was entirely obstructed by rockfill and that the outlet of one of the culvert was partially obstructed while the outlet of the other culvert was broken. It is recommended to observe this area at freshet and to clear the obstructions if insufficient capacity to handle the flow is observed.

Action: As part of the freshet action plan, the area for the culverts located on the Vault Road between the diversion ditches and Lake NP1 is closely monitored during freshet period. Some work was completed around the culverts during summer 2015 to ensure proper flow and to minimize erosion. The same inspections will be performed in 2016. If required, additional work will be performed in 2016.

6.2 Diversion Ditch and Sediment and Erosion Protection Structure

Recommendation: It is important that the erosion protection structure and sediment barriers be inspected during the next freshet season.

Action: The Diversion ditches as well as all structures and sediment barriers will be inspected during the 2017 freshet season as a part of the Freshet Action Plan.

6.3 Diffuser

Recommendation: The diffuser at Wally Lake had moved to a less deep water location and was spraying water in the air. It is recommended to repair this

diffuser so that the pipe is entering the lake to reduce the risk of shoreline erosion.

Action: A new diffuser will be installed in winter 2017 at its original place. More boulder will be use to avoid the diffuser to move again.

6.4 Stormwater Management Ponds

Recommendation: No geotechnical concerns were identified regarding the Stormwater Management Pond, or the crusher ramp located nearby. The geotechnical stability of the crusher ramp should be regularly inspected by AEM due to its proximity with Stormwater management pond.

Action: Inspection and monitoring of the roads is performed on regular basis and will continue. No geotechnical issues have been identified on the crusher ramp since the beginning of its operation.